

MT-66
TECHNICAL DATA

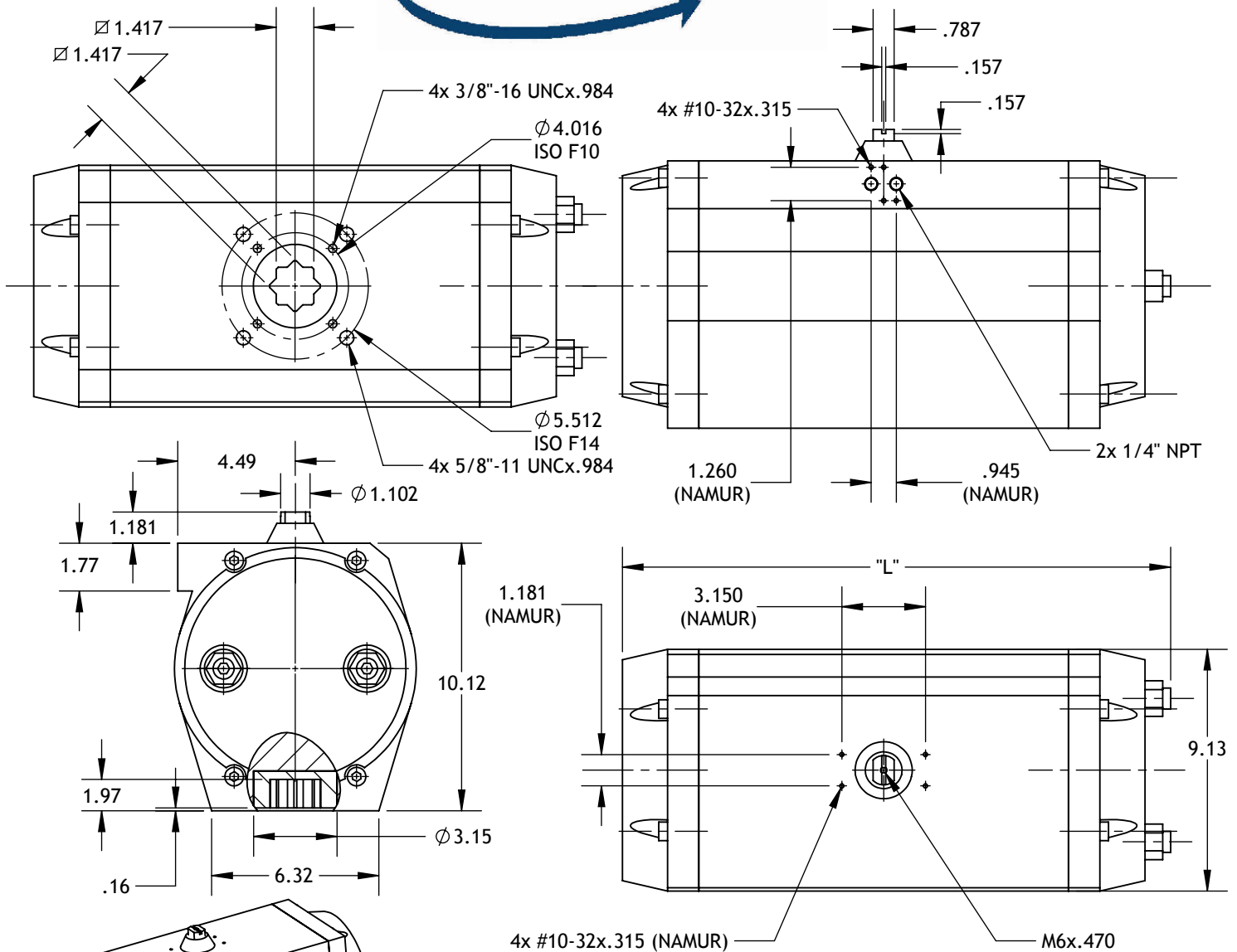

DIMENSIONS TO
ISO 5211 - DIN 3337
AND NAMUR VDI/VDE 3845

DIMENSIONS IN INCHES



WEIGHT

STROKE	DOUBLE ACTING					SPRING RETURN 7+5 SPRING
	90°	120°	135°	150°	180°	90°
LB.	84.5	CALL	CALL	CALL	CALL	105.6

AIR CONSUMPTION (FULL CYCLE)

	90°	120°	135°	150°	180°
"L"	19.764	22.717	24.213	25.709	28.661

STROKE	DOUBLE ACTING					SPRING RETURN 7+5 SPRING
	90°	120°	135°	150°	180°	90°
CU-IN.	1037.5	1275.0	1393.7	1512.5	1743.8	443.8

Max-Air Technology Inc.

751 Hoff Road - O'Fallon, Missouri 63366 U.S.A.
www.max-airtechnology.com info@max-airtechnology.com