

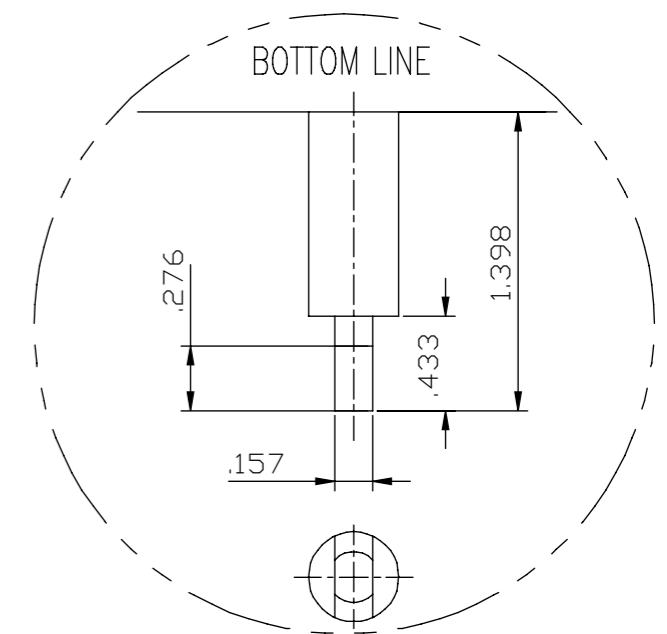

### SPECIFICATIONS

Applicable Fluid	Air		
Acting Type	<input type="checkbox"/> Single	<input type="checkbox"/> Double	
Input Signal	4~20 mA DC		
Impedance	250 ±15 Ω		
Supply Pressure	1.4 ~ 7 Kg/cm <sup>2</sup> (20 ~ 100 psi)		
Stroke	0° ~ 60°, 0° ~ 90°		
Connection	(N)PT 1/4		
Conduit	PF 1/2 (G 1/2), (N)PT 1/2		
Gauge Port	(N)PT 1/8		
Explosion Proof	<input type="checkbox"/> ExdmlBT5	<input type="checkbox"/> ExdmlCT5	<input type="checkbox"/> ExiallCT5
pressure Gauge	<input type="checkbox"/> 0~28 psi	<input type="checkbox"/> 0~57 psi	<input type="checkbox"/> 0~140 psi
Ambient Temp	-4°~158°F		
Linearity	±1.0% F.S.	±2.0% F.S.	
Hysteresis	±1.0% F.S.		
Sensitivity	±0.2% F.S.	±0.5% F.S.	
Repeatability	±0.5% F.S.		
Air Consumption	0.11 CFM (Sup.=20 psi)		
Flow Capacity	2.8 CFM (Sup.=20 psi)		
Weight	2.8 kg (6.1 lb)		
Actuator Shaft	NAMUR		
Material	ALUMINUM DIECASTING		



Item No.	DESCRIPTION	Material
1	BASE BODY	ALDC12
2	BASE COVER	ALDC12
3	PRESSURE GAUGE	STS 303
4	NAMUR SHAFT	STS 304

ASSEMBLY DRAWING	
Figure No's: PEY01-D	Reference No.
Description: Electro-Pneumatic Positioner, 4-20 mA, w/ Universal Mtg, Gages	
<b>MAX-AIR TECHNOLOGY, INC.</b>	
PEY01-D Electro-Pneumatic Positioner	
	
BY: BW DATE: 12-28-2010	DATE: 12-28-2010
REVISIONS: 1	