

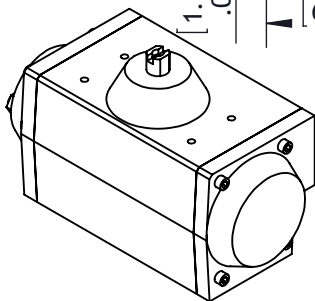

DIMENSIONS TO
ISO 5211 - DIN 3337
AND NAMUR VDI/VDE 3845
DIMENSIONS IN INCHES
[MM]

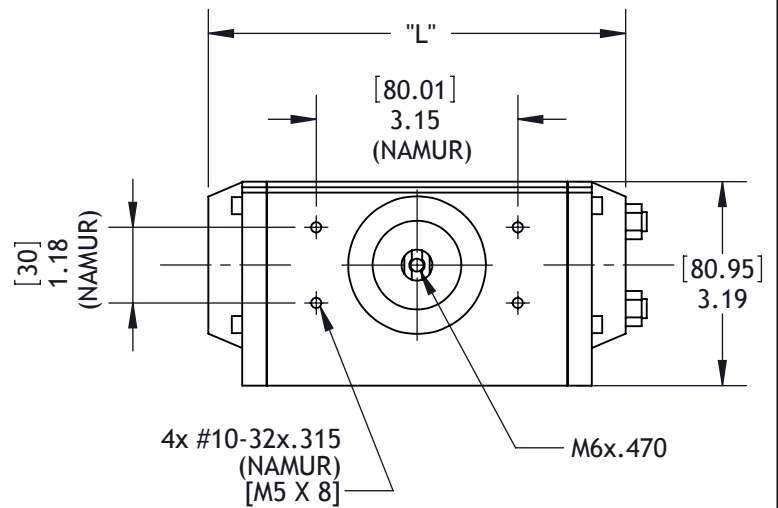
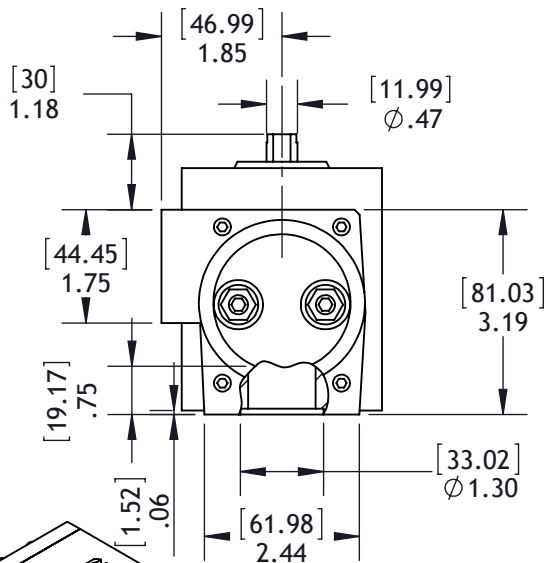
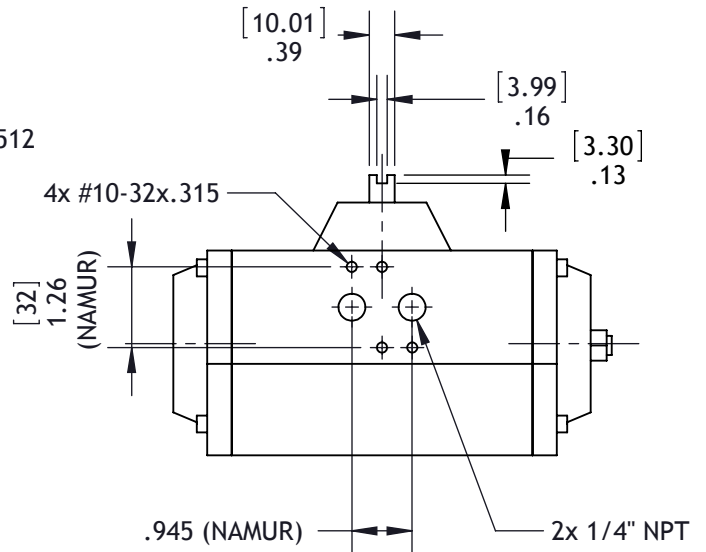
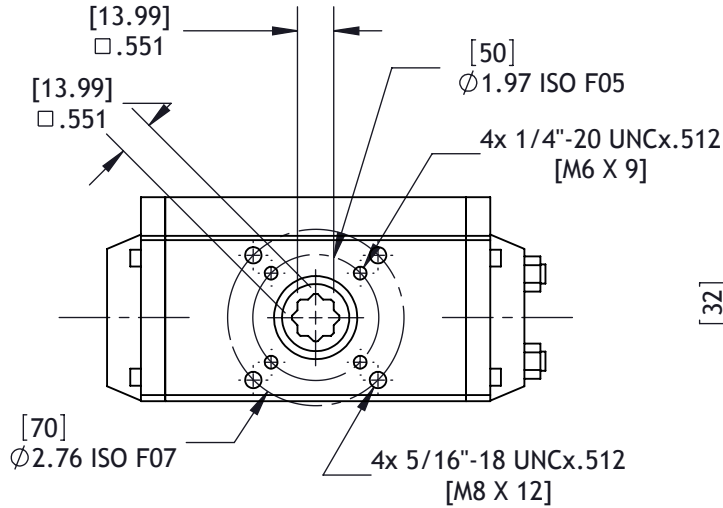

	90°	120°	135°	150°	180°
"L"	6.496	7.638	7.953	8.425	9.213

WEIGHT

STROKE	DOUBLE ACTING					SPRING RETURN 7+5 SPRING
	90°	120°	135°	150°	180°	90°
LB.	3.52	CALL	CALL	CALL	CALL	3.94

AIR CONSUMPTION (FULL CYCLE)

STROKE	DOUBLE ACTING					SPRING RETURN 7+5 SPRING
	90°	120°	135°	150°	180°	90°
CU.-IN.	25.6	32.4	34.4	37.5	42.5	11.20

MT-15

VALORI DI COPPIA in "Nm" TORQUE VALUES in "Nm"

DOPPIO EFFETTO DOUBLE ACTING

100 kPa = 1 Bar

100 kPa	200 kPa	300 kPa	400 kPa	500 kPa	562 kPa	600 kPa	700 kPa	800 kPa	900 kPa	1000 kPa
5,5	11,0	16,5	22,0	27,5	30,9	33,0	38,5	44,0	49,5	55,0

SEMPLICE EFFETTO 90° SPRING RETURN 90°

100 kPa = 1 Bar

POS. 1 COPPIA DI CHIUSURA (RITORNO MOLLE)		POS. 2 - COPPIA DI APERTURA - POS. 2 - OPENING TORQUE																				
		POS. 1 CLOSING TORQUE (SPRING)		200 kPa		300 kPa		400 kPa		500 kPa		562 kPa		600 kPa		700 kPa		800 kPa		900 kPa		1000 kPa
N° MOLLE # SPRINGS	START	END	START	END	START	END	START	END	START	END	START	END	START	END	START	END	START	END	START	END	START	END
1+1	4,2	3,0	8,0	6,8	13,5	12,3	19,0	17,8	24,5	23,3	27,9	26,7	30,0	28,8	35,5	34,3	41,0	39,8	46,5	45,3	52,0	50,8
2+2	8,4	6,0	5,0	2,6	10,5	8,1	16,0	13,6	21,5	19,1	24,6	22,5	27,0	24,6	32,5	30,1	38,0	35,6	43,5	41,1	49,0	46,6
3+3	12,6	9,1	--	--	7,4	3,9	12,9	9,4	18,4	14,9	21,8	18,3	23,9	20,4	29,4	25,9	34,9	31,4	40,4	36,9	45,9	42,4
4+4	16,9	12,1	--	--	--	--	9,9	5,1	15,4	10,6	18,8	14,0	20,9	16,1	26,4	21,6	31,9	27,1	37,4	32,6	42,9	38,1
5+5	21,1	15,1	--	--	--	--	6,9	0,9	12,4	6,4	15,8	9,8	17,9	11,9	23,4	17,4	28,9	22,9	34,4	28,4	39,9	33,9
7+5	25,3	18,1	--	--	--	--	--	--	9,4	2,2	12,8	5,6	14,9	7,7	20,4	13,2	25,9	18,7	31,4	24,2	36,9	29,7

MT-16

TORQUE VALUES in "IN.LB"

SPRING RETURN 90°

DOUBLE ACTING

40 PSIG	60 PSIG	80 PSIG	100 PSIG	120 PSIG
137	206	275	344	412

# SPRINGS	POS. 1 CLOSING TORQUE (SPRING)		POS. 2 - OPENING TORQUE									
	START	END	40 PSIG		60 PSIG		80 PSIG		100 PSIG		120 PSIG	
	START	END	START	END	START	END	START	END	START	END	START	END
1+1	37	27	110	100	179	169	248	238	317	307	385	375
2+2	75	53	84	62	153	131	222	200	291	269	359	337
3+3	112	81	56	25	125	94	194	163	263	232	331	300
4+4	150	107	--	--	99	56	168	125	237	194	305	262
5+5	187	134	--	--	72	19	141	88	210	157	278	225
7+5	224	160	--	--	--	--	115	51	184	120	252	188

PESI - WEIGHT

CORSA STROKE	DOPPIO EFFETTO -DOUBLE ACTING					SEMPLICE EFFETTO 7+5 MOLLE SPRING RETURN 7+5 SPRING
	90°	120°	135°	150°	180°	90°
Kg.	1,830	2,210	2,270	2,400	2,700	2,020
LB.	4.03	4.87	5.00	5.29	5.95	4.45

CONSUMI ARIA (CICLO COMPLETO) AIR CONSUMPTION (FULL CYCLE)

CORSA STROKE	DOPPIO EFFETTO -DOUBLE ACTING					SEMPLICE EFFETTO 7+5 MOLLE SPRING RETURN 7+5 SPRING
	90°	120°	135°	150°	180°	90°
N. Lt.	0,41	0,52	0,55	0,60	0,68	0,18
CU.-IN.	25.6	32.4	34.4	37.5	42.5	11.2

