

**MT56**  
TECHNICAL DATA



**MT55**  
DATI TECNICI

DIMENSIONS TO  
ISO 5211 - DIN 3337  
AND NAMUR VDI/VE 3845

DIMENSIONS IN INCHES  
[MM]

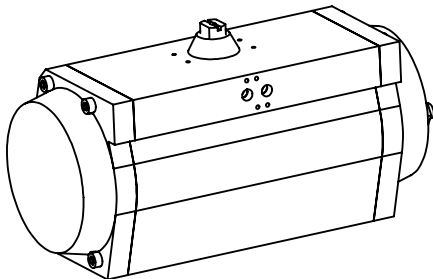
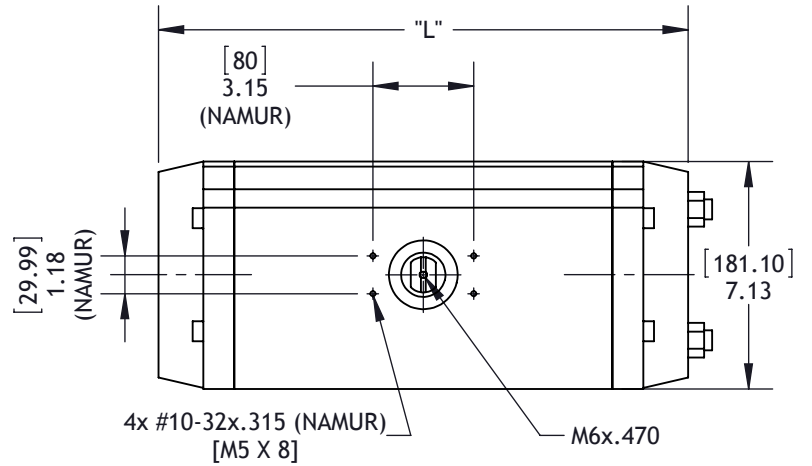
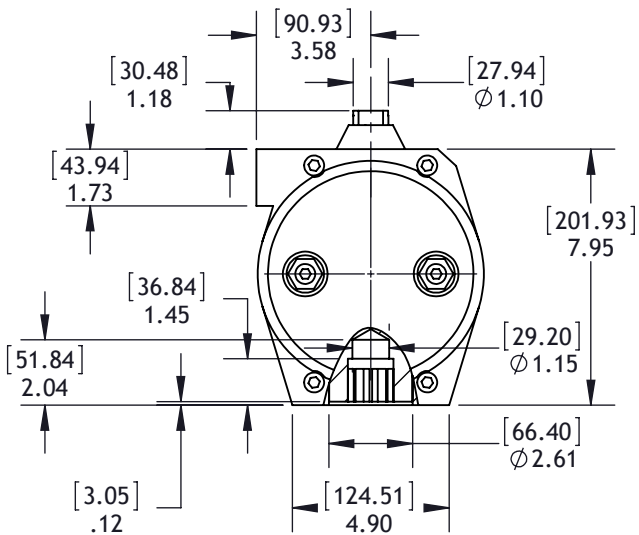
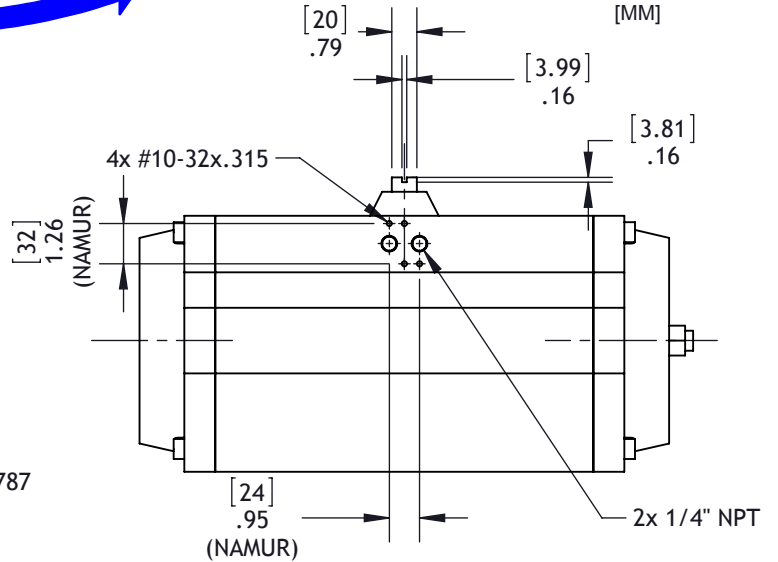
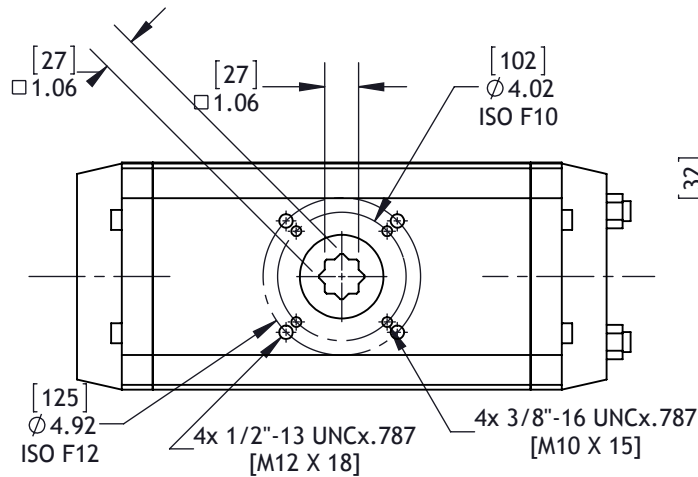

	90°	120°	135°	150°	180°
"L"	16.457	18.937	20.197	21.417	23.898

**WEIGHT**

STROKE	DOUBLE ACTING					SPRING RETURN 7+5 SPRING
	90°	120°	135°	150°	180°	90°
LB.	44.1	CALL	CALL	CALL	CALL	53.8

**AIR CONSUMPTION (FULL CYCLE)**

STROKE	DOUBLE ACTING					SPRING RETURN 7+5 SPRING
	90°	120°	135°	150°	180°	90°
CU.-IN.	565.5	681.3	737.5	793.8	906.3	256.3

# MT-55

## VALORI DI COPPIA in "Nm" TORQUE VALUES in "Nm"

### DOPPIO EFFETTO DOUBLE ACTING

100 kPa = 1 Bar

100 kPa	200 kPa	300 kPa	400 kPa	500 kPa	562 kPa	600 kPa	700 kPa	800 kPa	900 kPa	1000 kPa
120,8	241,6	362,3	483,1	603,9	676,4	724,7	845,5	966,3	1087,1	1207,8

### SEMPLICE EFFETTO 90° SPRING RETURN 90°

100 kPa = 1 Bar

N° MOLLE # SPRINGS		POS. 1 COPPIA DI CHIUSURA (RITORNO MOLLE)		POS. 2 - COPPIA DI APERTURA - POS. 2 - OPENING TORQUE																			
		POS. 1 CLOSING TORQUE (SPRING)		200 kPa		300 kPa		400 kPa		500 kPa		562 kPa		600 kPa		700 kPa		800 kPa		900 kPa		1000 kPa	
		START	END	START	END	START	END	START	END	START	END	START	END	START	END	START	END	START	END	START	END	START	END
1+1		83,9	59,6	182,0	157,7	302,7	278,4	423,5	399,2	544,3	520,0	616,8	592,5	665,1	640,8	785,9	761,6	906,7	882,4	1027,5	1003,2	1148,2	1123,9
2+2		167,9	119,1	122,5	73,7	243,2	194,4	364,0	315,2	484,8	436,0	557,3	508,5	605,6	556,8	726,4	677,6	847,2	798,4	968,0	919,2	1088,7	1039,9
3+3		251,8	178,7	--	--	183,6	110,5	304,0	231,3	425,2	352,1	497,7	424,6	546,0	472,9	666,8	593,7	787,6	714,5	908,4	835,3	1029,1	956,0
4+4		335,7	238,3	--	--	124,0	26,6	244,8	147,4	365,6	268,2	438,1	340,7	486,4	389,0	607,2	509,8	728,0	630,6	848,8	751,4	969,5	872,1
5+5		419,7	297,8	--	--	--	--	185,3	63,4	306,1	184,2	378,6	256,7	426,8	305,0	547,7	425,8	668,5	546,6	789,3	667,4	910,0	788,1
7+5		503,6	357,4	--	--	--	--	--	--	246,5	100,3	319,0	172,8	367,3	221,1	488,1	341,9	608,9	462,7	729,7	583,5	850,4	704,2

# MT-56

## TORQUE VALUES in "IN.LB"

SPRING RETURN 90°

### DOUBLE ACTING

40 PSIG	60 PSIG	80 PSIG	100 PSIG	120 PSIG
3000	4500	6000	7500	9000

# SPRINGS	POS. 1 CLOSING TORQUE (SPRING)		POS. 2 - OPENING TORQUE									
	START	END	40 PSIG		60 PSIG		80 PSIG		100 PSIG		120 PSIG	
	START	END	START	END	START	END	START	END	START	END	START	END
1+1	743	528	2472	2257	3972	3757	5472	5257	6972	6757	8472	8257
2+2	1487	1055	1945	1513	3445	3013	4945	4513	6445	6013	7945	7513
3+3	2231	1583	1417	769	2917	2269	4417	3769	5917	5269	7417	6769
4+4	2974	2111	889	26	2389	1526	3889	3026	5389	4526	6889	6026
5+5	3718	2638	--	--	1862	782	3362	2282	4862	3782	6362	5282
7+5	4462	3166	--	--	1334	38	2834	1538	4334	3038	5834	4538

### PESI - WEIGHT

CORSA STROKE	DOPPIO EFFETTO -DOUBLE ACTING					SEMPLICE EFFETTO 7+5 MOLLE SPRING RETURN 7+5 SPRING
	90°	120°	135°	150°	180°	90°
Kg.	22,180	24,750	26,050	27,350	29,850	27,000
LB.	48.90	54.56	57.43	60.29	65.81	59.53

### CONSUMI ARIA (CICLO COMPLETO) AIR CONSUMPTION (FULL CYCLE)

CORSA STROKE	DOPPIO EFFETTO -DOUBLE ACTING					SEMPLICE EFFETTO 7+5 MOLLE SPRING RETURN 7+5 SPRING
	90°	120°	135°	150°	180°	90°
N. Lt.	9,00	10,90	11,80	12,70	14,50	4,10
CU.-IN.	565.5	681.3	737.5	793.8	906.3	256.3

