

MT66 F10-F12
TECHNICAL DATA



MT65 F10-F12
DATI TECNICI

DIMENSIONS TO
ISO 5211 - DIN 3337
AND NAMUR VDI/VDE 3845

DIMENSIONS IN INCHES
[MM]

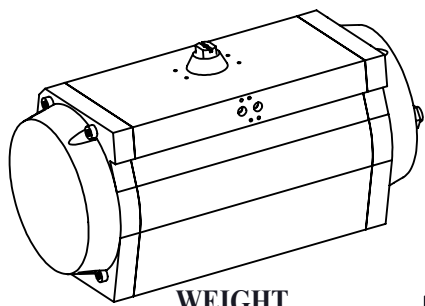
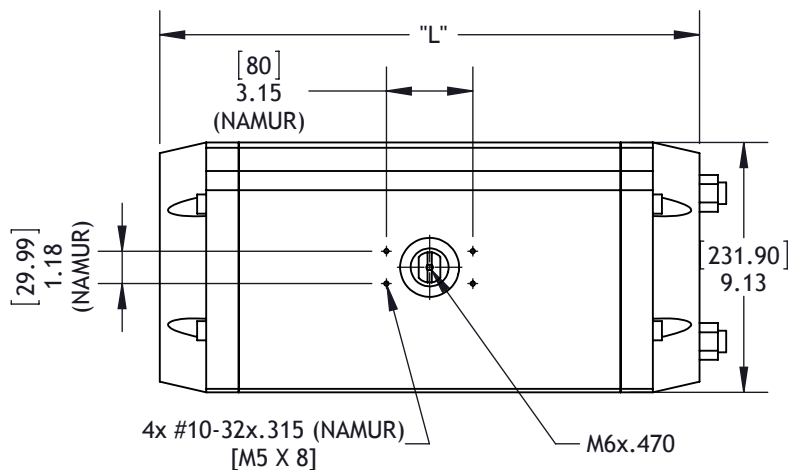
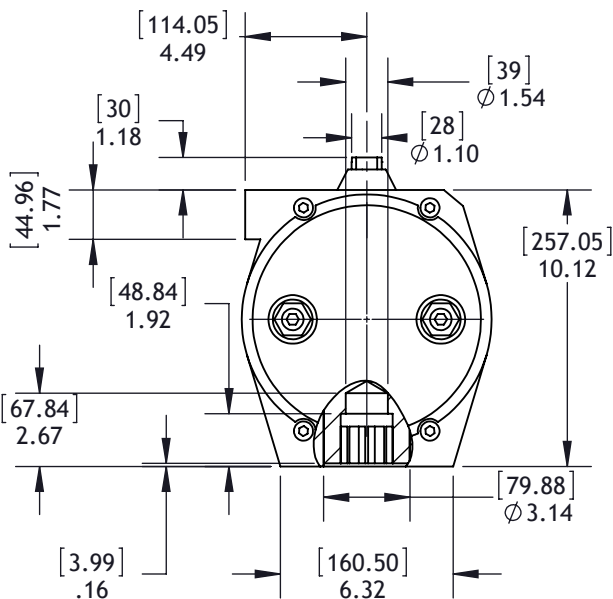
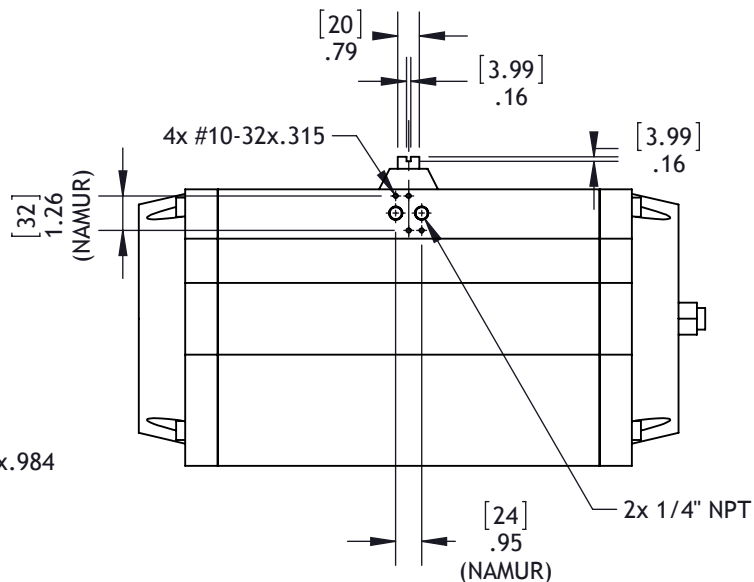
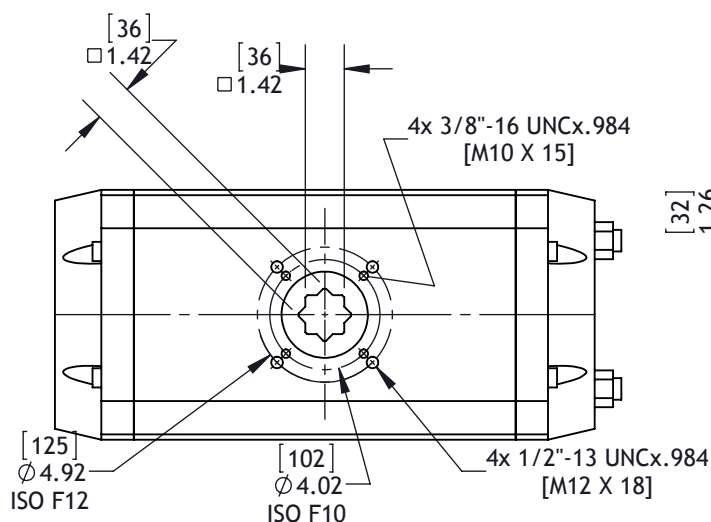

WEIGHT

STROKE	DOUBLE ACTING					SPRING RETURN 7+5 SPRING
	90°	120°	135°	150°	180°	90°
LB.	84.5	CALL	CALL	CALL	CALL	105.6

	90°	120°	135°	150°	180°
"L"	19.764	22.717	24.213	25.709	28.661

AIR CONSUMPTION (FULL CYCLE)

STROKE	DOUBLE ACTING					SPRING RETURN 7+5 SPRING
	90°	120°	135°	150°	180°	90°
CU.-IN.	1037.5	1275.0	1393.7	1512.5	1743.8	443.8

MT-65

VALORI DI COPPIA in "Nm" TORQUE VALUES in "Nm"

DOPPIO EFFETTO DOUBLE ACTING

100 kPa = 1 Bar

100 kPa	200 kPa	300 kPa	400 kPa	500 kPa	562 kPa	600 kPa	700 kPa	800 kPa	900 kPa	1000 kPa
241,6	483,2	724,8	966,4	1208,0	1357,8	1449,6	1691,2	1932,8	2174,4	2416,0

SEMPLICE EFFETTO 90° SPRING RETURN 90°

100 kPa = 1 Bar

N° MOLLE # SPRINGS	POS. 1 COPPIA DI CHIUSURA (RITORNO MOLLE)		POS. 2 - COPPIA DI APERTURA - POS. 2 - OPENING TORQUE																				
	POS. 1 CLOSING TORQUE (SPRING)		200 kPa		300 kPa		400 kPa		500 kPa		562 kPa		600 kPa		700 kPa		800 kPa		900 kPa		1000 kPa		
	START	END	START	END	START	END	START	END	START	END	START	END	START	END	START	END	START	END	START	END	START	END	START
1+1	158,6	117,6	365,6	324,6	607,2	566,2	848,8	807,8	1090,4	1049,4	1240,2	1049,4	1332,0	1291,0	1573,6	1532,6	1815,2	1774,2	2056,8	2015,8	2298,4	2257,4	
2+2	317,1	235,2	248,0	166,1	489,6	404,7	731,2	649,3	972,8	890,9	1122,6	1040,7	1214,4	1132,5	1456,6	1374,1	1697,6	1615,5	1939,2	1857,3	2180,8	2098,9	
3+3	475,7	352,8	130,4	7,5	372,0	249,1	613,6	490,7	855,2	732,3	1005,0	882,1	1096,8	973,9	1338,4	1215,5	1580,0	1457,1	1821,6	1698,7	2063,2	1940,3	
4+4	634,2	470,5	--	--	254,3	90,6	495,9	332,2	737,5	573,8	887,3	723,6	979,1	815,4	1220,7	1057,0	1462,3	1298,6	1703,9	1540,2	1945,5	1781,8	
5+5	792,8	588,1	--	--	--	--	378,3	173,6	619,9	415,2	769,7	565,0	861,5	656,8	1103,1	898,4	1344,7	1140,0	1586,3	1381,6	1827,9	1623,2	
7+5	951,6	705,6	--	--	--	--	260,8	14,8	502,4	256,4	652,2	406,2	744,0	498,0	985,6	739,6	1227,2	981,2	1468,8	1222,8	1710,4	1464,4	

MT-66

TORQUE VALUES in "IN.LB"

SPRING RETURN 90°

DOUBLE ACTING

40 PSIG	60 PSIG	80 PSIG	100 PSIG	120 PSIG
6000	9000	12000	15000	18000

# SPRINGS	POS. 1 CLOSING TORQUE (SPRING)		POS. 2 - OPENING TORQUE									
			40 PSIG		60 PSIG		80 PSIG		100 PSIG		120 PSIG	
	START	END	START	END	START	END	START	END	START	END	START	END
1+1	1405	1042	4958	4595	7958	7595	10958	10595	13958	13595	16958	16595
2+2	2810	2084	3916	3190	6916	6190	9916	9190	12916	12190	15916	15190
3+3	4215	3126	2874	1785	5874	4785	8874	7785	11874	10785	14874	13785
4+4	5619	4169	1831	381	4831	3381	7831	6381	10831	9381	13831	12381
5+5	7024	5211	--	--	3789	1976	6789	4976	9789	7976	12789	10976
7+5	8430	6252	--	--	--	--	5748	3570	8748	6570	11748	9570

PESI - WEIGHT

CORS STROKE	DOPPIO EFFETTO - DOUBLE ACTING					SEMPLICE EFFETTO 7+5 MOLLE SPRING RETURN 7+5 SPRING
	90°	120°	135°	150°	180°	90°
Kg.	42,800	48,370	51,150	53,940	59,500	52,400
LB.	94,36	106,64	112,77	118,92	131,18	115,52

CONSUMI ARIA (CICLO COMPLETO) AIR CONSUMPTION (FULL CYCLE)

CORS STROKE	DOPPIO EFFETTO - DOUBLE ACTING					SEMPLICE EFFETTO 7+5 MOLLE SPRING RETURN 7+5 SPRING
	90°	120°	135°	150°	180°	90°
N. Lt.	16,60	20,40	22,30	24,20	27,90	7,10
CU.-IN.	1037,5	1275,0	1393,7	1512,5	1743,8	443,8

