

Max-Air

TECHNOLOGY

The Best Way To Automate Your Process

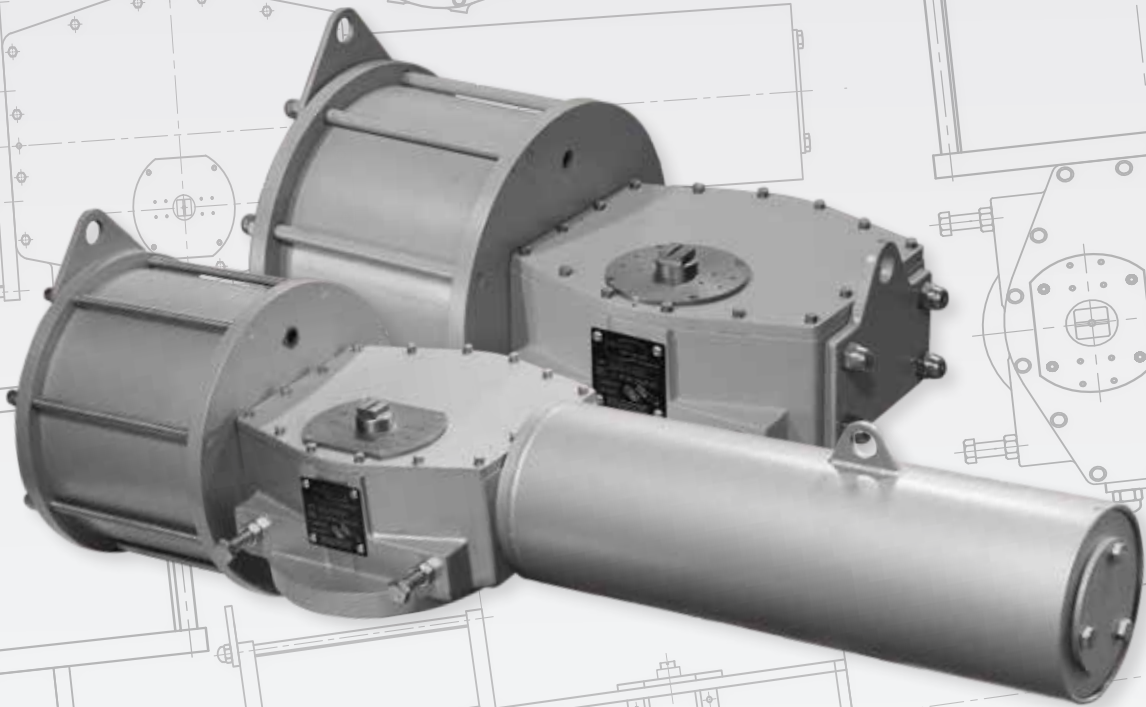

Heavy Duty
Pneumatic Actuators
SHD and CHD series

Scotch Yoke Actuators

2016 EDITION



Max-Air Technology, Inc. 751 Hoff Rd O'Fallon, Missouri 63366
Tel: +1.636.272.4934 Toll Free: 888.842.9998 Fax: 636.272.4937
www.maxairtech.com E-mail: info@maxairtech.com

HD SERIES SCOTCH YOKE ACTUATORS

SHD (symmetric type) and CHD (canted type) heavy duty scotch yoke actuators are designed to perform in the most demanding applications. They are engineered to automate all types of quarter turn valves (ball, butterfly, plug and damper) with multiple torque profiles available in order to provide a “best fit” for every situation. Torque range is up to 2,700,000 in-lbs double acting, and 1,300,000 Spring Return.

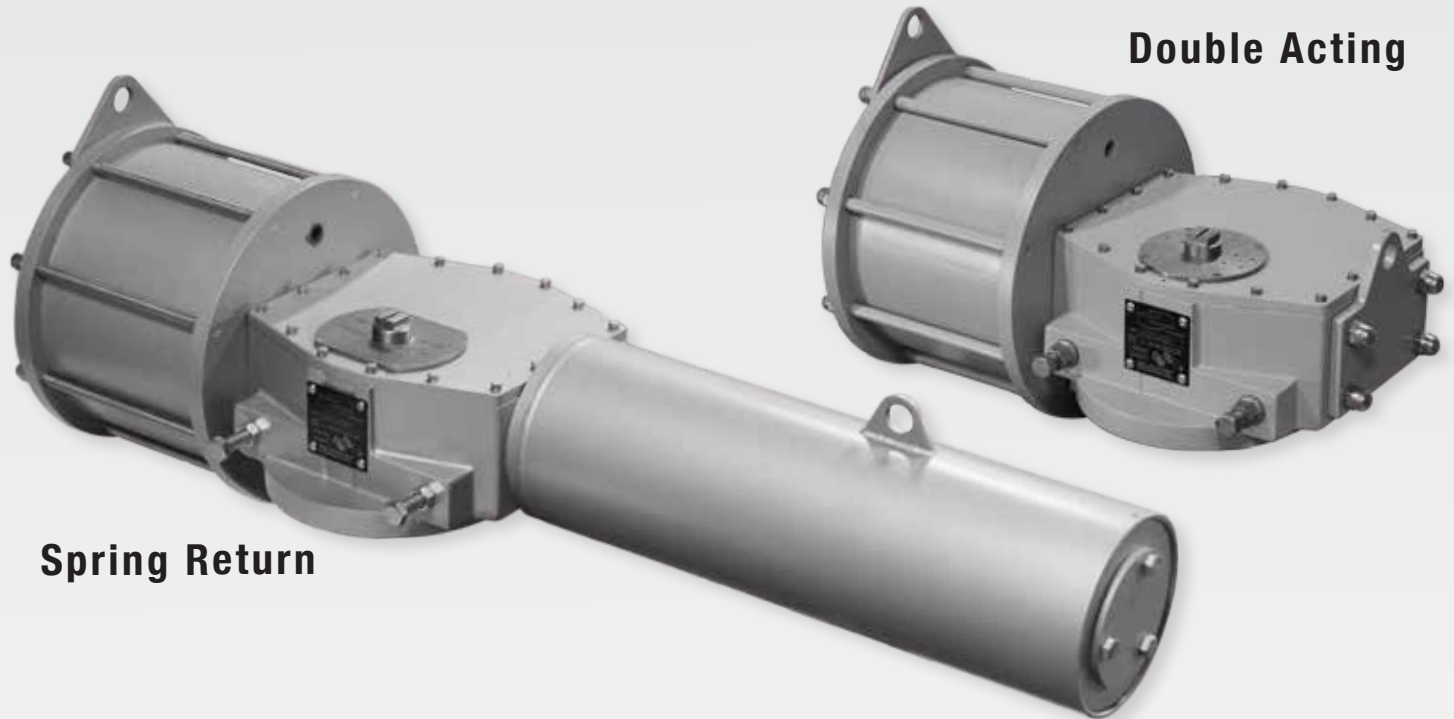

Spring Return

Double Acting

SPECIFICATIONS	
Rotation	90°F ± 6°F Adjustment
Housing	Epoxy Coated Ductile Iron
Yoke, Slide Block & Pin	Alloy Steel
Slide Block Bearings	High Strength Copper Alloy, Graphite Impregnated
Piston Rod & Spring Rod	Alloy Steel
Air Cylinder Piston	Alloy Steel
Spring & Spring Retainer	Alloy Steel
Seals	BUNA-N Standard (high & low temp options)
Fasteners	Alloy Steel
Ambient Temperature Range	-4°F to 176°F Standard (high & low temp options)
Operating Pressure	60 to 90 PSI
Max Pressure Rating	100 PSI
Torque Range	10,000 in-lbs to 2,700,000 in-lbs (DA)
Valve Mounting	ISO 5211
Top Accessory Mounting	NAMUR VDI/VDE 3845

Features:

- Symmetric and Canted Yoke options
- Slide Block Technology extends service life
- Hard chrome plated wear surfaces
- Travel stops with ±6° adjustment in both directions
- Three layer epoxy coating for general corrosion resistance
- Direct ISO 5211 standard valve mounting
- Direct NAMUR top accessory mounting
- Modular design w/ self-contained spring modules

Configurations:

- Double-Acting (Air-to-Air) operation
- Spring-Return (Air-to-Spring) operation, Fail-Close or Fail-Open
- Standard Rotation (CCW open) or Reverse Rotation (CW open)

Options:

- Manual override handpump or declutch gear operator
- Heavy duty polyamide epoxy coating
- Low temp or high temp seals
- High pressure hydraulic cylinder configurations

MAX-AIR TECHNOLOGY EXCLUSIVE

Designed to perform in the most demanding conditions!

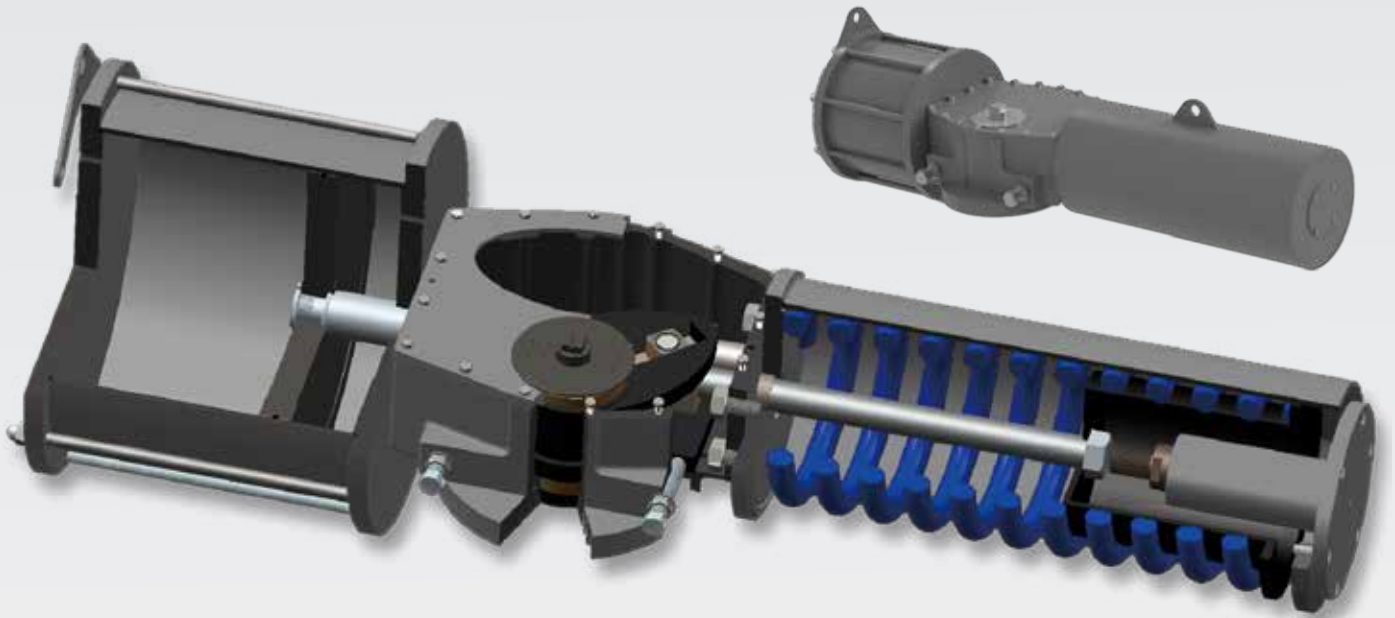

CYLINDER



The internal wall of the cylinder is hard chrome plated in order to maximize wear and corrosion resistance.

SLIDE BLOCK TECHNOLOGY



The slide block has a wide surface contact area, impregnated with graphite, that assures lower contact forces and smoother operation and is designed to withstand higher forces through load distribution, thereby protecting process critical equipment.

ISO AND NAMUR STANDARD



Both series have a bottom interface in accordance with the ISO 5211 standard. This helps provide for easy valve to actuator connection. The top-works dimensions, both for shaft height and mounting pattern are according to NAMUR standards allowing for easy and standard accessory attachment.

DOUBLE TRAVEL STOP

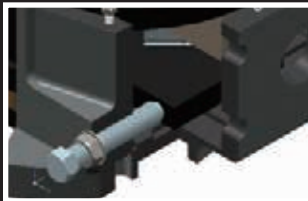

The SHD and CHD actuators are all provided with bi-directional travel stops to allow for open and closed position location adjustments of +/- 6 degrees.

Symmetric Torque Curves

Symmetric Type



Double Acting Actuator

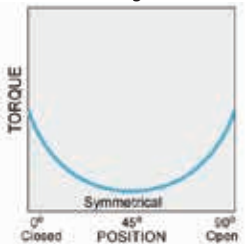

SHD series is equipped with a SYMMETRIC design yoke that produces maximum torques at both ends of the stroke (0° and 90°) and minimal in the middle, therefore this series is the optimal solution for metal seated ball valves, plug valves and for modulating service.

Canted Torque Curves

Canted Type



Double Acting Actuator

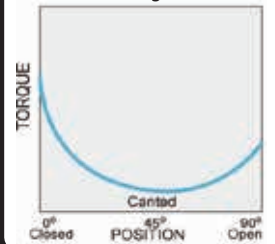

CHD series is equipped with a CANTED design yoke that produces a higher maximum torque at the beginning of stroke (i.e. valve unseating/reseating at 0°) and less torque at the end of stroke (90°), therefore this series is optimal solution for high performance butterfly valves.

FLEXIBLE CONFIGURATIONS

Provides maximized operational flexibility in selection and combination of power cylinder, body, and spring pack depending on project requirements.

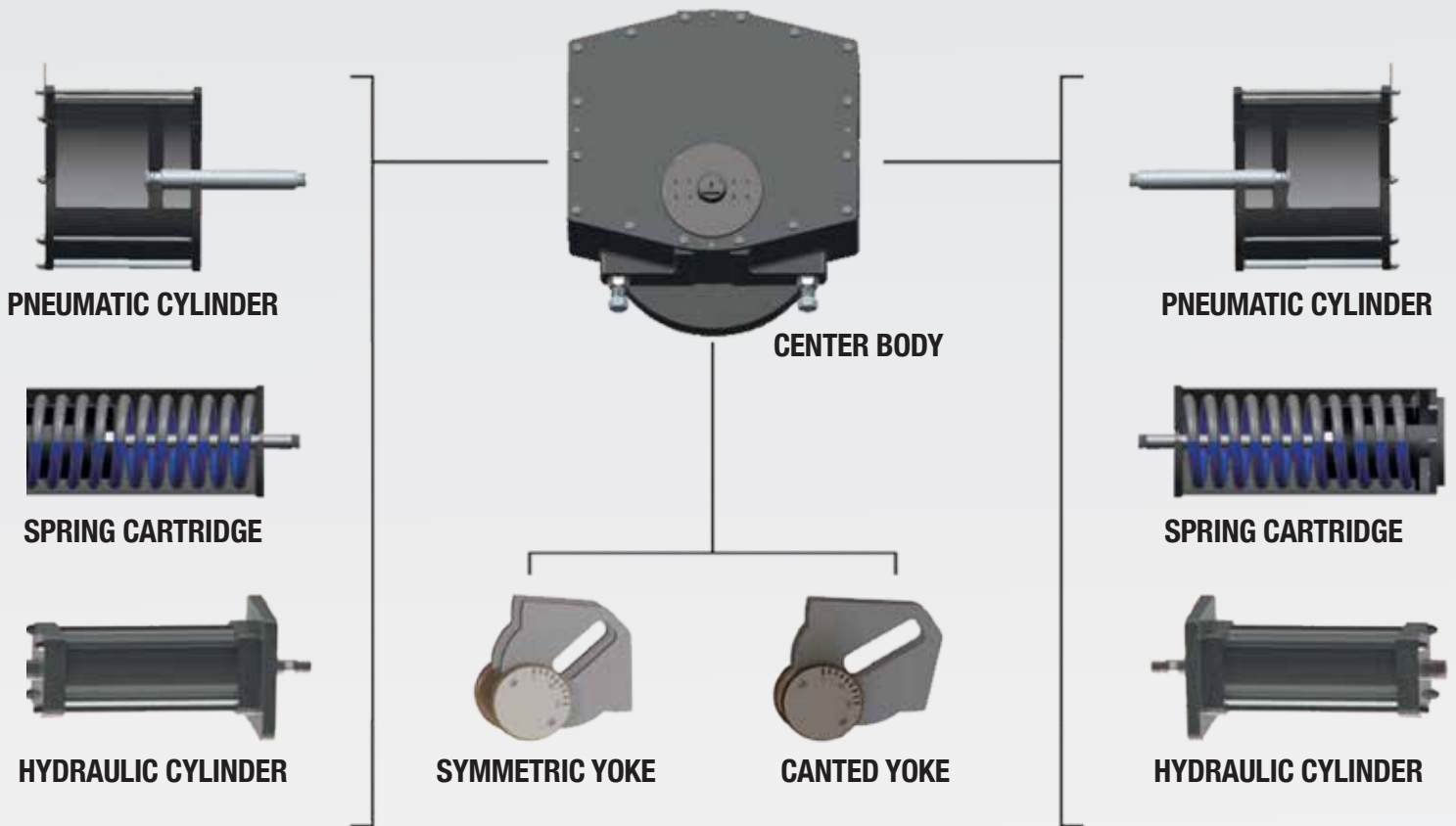

ORDERING CODE

(A)HD	B	-	U	C	D	E	F	G																								
<p>A - ACTUATOR TYPE</p> <p>S = SYMMETRIC TYPE</p> <p>C = CANTED TYPE</p> <p>HS = HYDRAULIC SYMMETRIC TYPE</p> <p>HC = HYDRAULIC CANTED TYPE</p>	<p>B - ACTUATOR SIZE</p> <table border="0"> <tr> <td>16</td> <td>35</td> <td>48</td> </tr> <tr> <td>25</td> <td>40</td> <td>60</td> </tr> <tr> <td>30</td> <td></td> <td></td> </tr> </table>	16	35	48	25	40	60	30				<p>U = NPT AIR CONNECTIONS</p>	<p>C - CYLINDER SIZE</p> <table border="0"> <tr> <td>020</td> <td>043</td> <td>068</td> </tr> <tr> <td>025</td> <td>048</td> <td>073</td> </tr> <tr> <td>030</td> <td>053</td> <td>080</td> </tr> <tr> <td>035</td> <td>058</td> <td>090</td> </tr> <tr> <td>038</td> <td>063</td> <td>100</td> </tr> </table>	020	043	068	025	048	073	030	053	080	035	058	090	038	063	100	<p>D - ACTUATOR TYPE</p> <p>0 Double Acting</p> <p>A Spring Return - A Spring Size</p> <p>B Spring Return - B Spring Size</p>	<p>E - SEAL MATERIAL</p> <p>0 NBR - BUNA</p> <p>1 HNBR (Low Temp)</p> <p>2 Viton (High Temp)</p>	<p>F - ASSEMBLY TYPE</p> <p>1 Standard Rotation Open CCW (Fail CW for Spring Return)</p> <p>4 Reverse Rotation Open CW (Fail CCW for Spring Return)</p>	<p>G - ACCESSORIES</p> <p>Blank None</p> <p>T* Extended Travel stops</p> <p>H* Jack Screw Handwheel</p> <p>Y Hydraulic Handpump</p> <p>*Note: not on all sizes</p>
16	35	48																														
25	40	60																														
30																																
020	043	068																														
025	048	073																														
030	053	080																														
035	058	090																														
038	063	100																														

MATERIALS OF CONSTRUCTION

(See Chart Below)

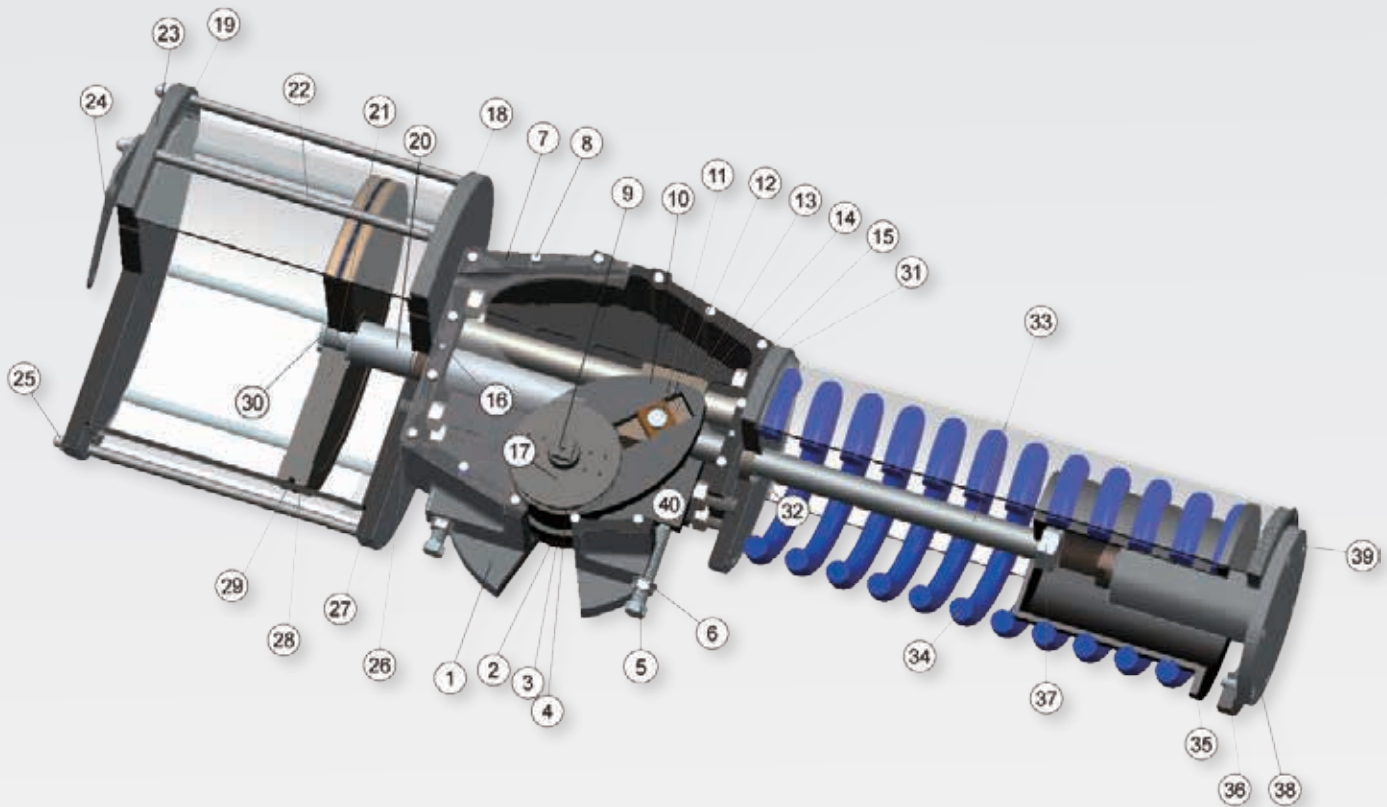

No.	DESCRIPTION	MATERIAL
1	Air & Spring Cylinders	Ductile Iron
2	Lower Bushing	Low Carbon Steel+Copper Alloy
3	Bushing O-Ring	NBR (High & Low Temp options)
4	Upper Bushing	Low Carbon Steel+Copper Alloy
5	Travel Stop	Stainless Steel / Plated Carbon Steel
6	Travel Stop Nut	Stainless Steel / Plated Carbon Steel
7	Center Cover	Ductile Iron
8	Center Cover Bolt	Stainless Steel
9	NAMUR Stem	Plated Carbon Steel
10	Yoke	Ductile Iron
11	Snap Ring	Stainless Steel
12	Slide Pin	Alloy Steel
13	Sliding Block	High strength copper alloy+Graphite
14	Guide Block	Plated Carbon Steel
15	Spring Module Bolt	Carbon Steel
16	Cover Fixed Pin	Stainless Steel
17	NAMUR Mounting Plate	Plated Carbon Steel
18	Cylinder Outer Cap	Carbon Steel
19	Cylinder Outer O-Ring	NBR (High & Low Temp options)
20	Piston Rod	Chrome Plated Carbon Steel

No.	DESCRIPTION	MATERIAL
21	Piston	Carbon Steel
22	Tie Bolt	Stainless Steel / Plated Carbon Steel
23	Cylinder Inner Cap	Carbon Steel
24	Lift Plate	Carbon Steel
25	Tie Bolt Nut	Stainless Steel
26	Cylinder Cap Bushing	Low Carbon Steel+Copper Alloy
27	Cylinder Inner O-Ring	NBR (High & Low Temp options)
28	Piston Wear Bearing	PTFE bronze composite
29	Piston O-Ring	NBR (High & Low Temp options)
30	Piston Lock Bolt	Carbon Steel
31	Spring Case Inner Cap	Carbon Steel
32	Spring Rod Guide Bushing	Low Carbon Steel+Copper Alloy
33	Spring Rod	Chrome Plated Carbon Steel
34	Spring	Alloy Steel
35	Spring Retainer	Carbon Steel
36	Spring Case Outer Cap	Carbon Steel
37	Spring Rod Lock Nut	Carbon Steel
38	Hydraulic Override Cylinder (Optional)	Carbon Steel
39	Outer Cap Bolt	Carbon Steel
40	Center Module	Ductile Iron

SHD SERIES-SYMMETRIC DESIGN

Double Acting Actuator

Spring Return Actuator

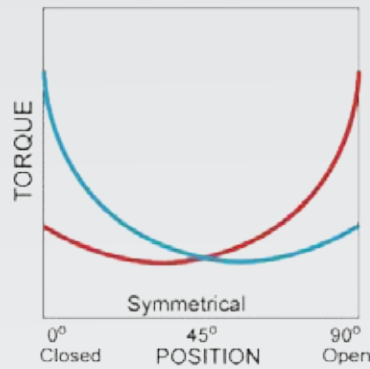
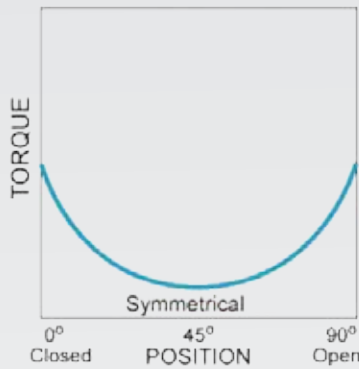

Torque Curve — Air Torque (blue line), Spring Torque (red line)

DOUBLE ACTING

Values in in-lbs

MODEL	60 PSI			80 PSI			90 PSI		
	0°	RUN	90°	0°	RUN	90°	0°	RUN	90°
SHD16-U020001	13,367	8,311	12,844	17,841	11,082	17,135	22,304	13,852	21,415
SHD16-U025001	20,907	12,988	20,376	27,876	17,313	27,170	34,845	21,642	33,960
SHD16-U030001	30,106	18,701	29,575	40,143	24,933	39,437	50,179	31,165	49,294
SHD16-U035001	40,980	25,456	40,450	54,637	33,938	53,932	68,298	42,420	67,414
SHD25-U035001	49,603	30,811	48,165	66,141	41,083	64,219	82,678	51,351	80,277
SHD25-U038001	58,473	36,321	57,035	77,964	48,428	76,042	97,459	60,536	95,053
SHD25-U043001	74,876	46,509	73,430	99,835	62,009	97,913	124,794	77,513	122,392
SHD30-U043001	96,039	59,653	93,523	128,052	79,535	124,701	160,065	99,417	155,876
SHD30-U048001	119,673	74,327	117,157	159,558	99,103	156,212	199,447	123,882	195,267
SHD30-U053001	145,899	90,620	143,390	194,535	120,827	191,184	243,167	151,034	238,982
SHD35-U053001	179,282	111,354	175,226	239,044	148,476	233,630	298,807	185,595	292,038
SHD35-U058001	214,706	133,358	210,651	286,275	177,812	280,865	357,843	222,266	351,078
SHD35-U063001	253,324	157,340	249,261	337,761	209,789	332,351	422,202	262,237	415,437
SHD40-U063001	316,218	196,408	308,310	421,619	261,874	411,078	527,023	327,344	513,850
SHD40-U068001	368,402	228,820	360,494	491,199	305,092	480,654	613,999	381,368	600,822
SHD40-U073001	424,569	263,705	416,661	566,087	351,608	555,547	707,610	439,511	694,432
SHD48-U068001	501,759	311,295	491,727	669,007	414,253	655,631	836,269	519,434	819,549
SHD48-U073001	687,799	427,214	674,033	917,065	569,616	898,713	1,146,331	712,025	1,091,709
SHD48-U080001	825,356	512,636	808,843	1,100,469	683,515	1,078,452	1,375,597	854,393	1,348,075
SHD60-U080001	1,072,944	666,417	1,051,487	1,430,592	888,559	1,401,980	1,788,240	1,110,693	1,752,480
SHD60-U090001	1,358,352	843,701	1,331,184	1,811,136	1,124,932	1,774,912	2,263,920	1,406,170	2,218,640
SHD60-U100001	1,676,932	1,041,567	1,643,394	2,235,910	1,388,758	2,191,192	2,794,887	1,735,942	2,738,990

SPRING RETURN

Values in in-lbs

MODEL	SPRING TORQUE			AIR TORQUE AIR SUPPLY PRESSURE									
				60 PSI			80 PSI			90 PSI			
	0°	RUN	90°	0°	RUN	90°	0°	RUN	90°	0°	RUN	90°	
SHD16-U020*01	A	5,328	4,381	8,629	8,038	3,930	4,214	12,513	6,701	8,506			
	B	6,992	5,753	11,329				10,849	5,329	5,807	15,312	8,099	10,086
SHD16-U025*01	A	8,081	6,647	13,090	12,826	6,341	7,286	19,795	10,666	14,080			
	B	10,966	9,019	17,763				16,910	9,664	9,406	23,878	14,090	16,196
SHD16-U030*01	A	11,515	9,559	18,949	18,591	9,142	10,626	28,628	15,374	20,487			
	B	15,816	13,002	25,614				24,326	11,931	13,823	34,363	18,164	23,680
SHD16-U035*01	A	14,409	11,966	23,711	26,571	13,490	16,739	40,228	21,972	30,220			
	B	18,941	15,568	30,677				35,697	18,370	23,255	49,358	26,852	36,737
SHD25-U035*01	A	15,958	13,621	27,420	33,646	17,190	20,746	50,183	27,462	36,800			
	B	22,711	18,764	37,076				43,430	22,320	27,143	59,967	32,588	43,201
SHD25-U038*01	A	21,950	18,135	35,828	36,523	18,186	21,207	56,014	30,293	40,214			
	B	29,234	24,154	47,714				48,730	24,275	28,328	68,225	36,382	47,339
SHD25-U043*01	A	26,986	22,295	44,050	47,890	24,214	29,380	72,849	39,714	53,863			
	B	36,262	31,456	63,929				63,573	30,553	33,984	88,532	46,057	58,463
SHD30-U043*01	A	36,881	31,588	63,743	59,158	28,065	29,780	91,171	47,947	60,958			
	B	48,113	41,209	83,153				79,940	38,326	41,549	111,953	58,207	72,724
SHD30-U048*01	A	45,360	38,855	78,391	74,313	35,472	38,766	114,198	60,248	77,821			
	B	56,698	49,405	100,651				102,860	49,698	55,561	142,749	74,477	94,616
SHD30-U053*01	A	54,999	47,113	95,101	90,900	43,508	48,289	139,536	73,714	96,083			
	B	72,895	62,433	125,982				121,640	58,394	65,203	170,272	88,601	113,000
SHD35-U053*01	A	67,717	57,574	115,679	111,565	53,780	59,546	171,327	90,902	117,951			
	B	90,313	76,780	154,277				148,731	71,696	79,353	208,494	108,815	137,761
SHD35-U058*01	A	82,277	68,443	137,523	132,429	64,915	73,128	203,998	109,369	143,342			
	B	107,306	91,233	183,299				178,968	86,579	97,566	250,537	131,033	167,779
SHD35-U063*01	A	97,102	82,560	165,881	156,222	74,780	83,380	240,659	127,229	166,470			
	B	125,034	106,297	213,586				212,726	103,491	118,765	297,167	155,939	201,851
SHD40-U063*01	A	119,096	102,739	208,125	197,123	93,668	100,184	302,523	159,134	202,953			
	B	151,277	130,495	264,363				270,342	131,242	146,715	375,746	196,702	249,487
SHD40-U068*01	A	134,912	116,378	235,757	233,491	112,442	124,736	356,287	188,714	244,897			
	B	181,210	156,322	316,671				309,989	148,770	163,983	432,789	225,046	284,151
SHD40-U073*01	A	157,685	136,018	275,559	266,884	127,686	141,102	408,402	215,590	279,988			
	B	204,974	176,820	358,199				361,113	174,788	197,348	502,635	262,690	336,234
SHD48-U068*01	A	195,929	168,899	326,539	305,830	142,396	165,187	473,078	245,354	329,091			
	B	254,707	219,569	424,499				414,300	194,684	231,131	581,563	299,865	395,049
SHD48-U073*01	A	268,576	231,518	447,626	419,223	195,696	226,406	648,489	338,098	451,087			
	B	349,144	300,978	581,919				576,771	268,637	316,794	806,038	411,047	509,790
SHD48-U080*01	A	322,282	277,825	537,134	503,074	234,811	271,709	778,187	405,690	541,318			
	B	418,968	361,172	698,280				681,502	322,342	380,172	956,629	493,221	649,796
SHD60-U080*01	A	418,968	361,181	698,280	653,976	305,236	353,207	1,011,624	527,378	703,700			
	B	544,657	469,532	907,759				885,935	419,027	494,221	1,243,583	641,161	844,721
SHD60-U090*01	A	530,416	457,256	884,030	827,935	386,445	447,154	1,280,720	667,676	890,882			
	B	689,544	594,434	1,149,243				1,121,592	530,498	625,669	1,574,376	811,736	1,069,397
SHD60-U100*01	A	654,822	564,492	1,091,368	1,022,110	477,075	552,026	1,581,088	824,267	1,099,824			
	B	851,265	733,842	1,418,775				1,384,645	654,916	772,417	1,943,623	1,002,100	1,320,215

* = spring type A or B in the model number indicates the selection of either the "A" or "B" spring from the table above.

CHD SERIES-CANTED DESIGN

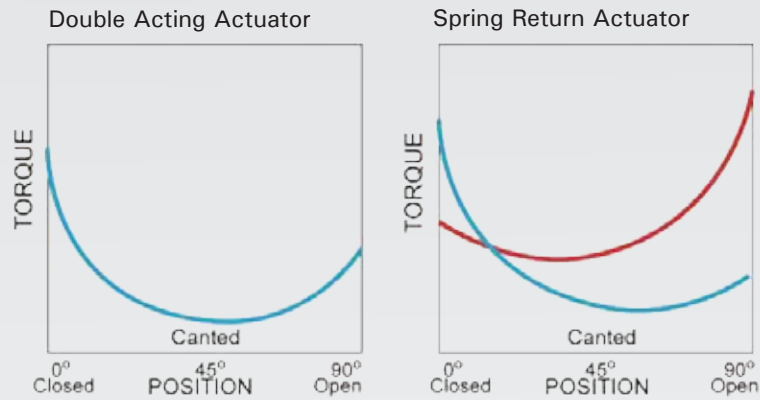

Torque Curve — Air Torque — Spring Torque

DOUBLE ACTING

Values in in-lbs

MODEL	60 PSI			80 PSI			90 PSI		
	0°	RUN	90°	0°	RUN	90°	0°	RUN	90°
CHD16-U020001	16,806	8,311	11,708	22,408	11,082	15,613	28,010	13,852	19,519
CHD16-U025001	26,261	12,988	18,298	35,012	17,313	24,396	43,763	21,642	30,494
CHD16-U030001	37,814	18,701	26,352	50,417	24,933	35,132	63,020	31,165	43,915
CHD16-U035001	51,470	25,456	35,864	68,622	33,938	47,820	85,778	42,420	59,773
CHD25-U035001	62,300	30,811	43,416	83,068	41,083	57,886	103,848	51,351	72,356
CHD25-U038001	73,439	36,321	51,177	97,922	48,428	68,231	122,401	60,536	85,293
CHD25-U043001	94,035	46,509	65,531	125,385	62,009	87,373	156,731	77,513	109,215
CHD30-U043001	120,616	59,653	84,047	160,819	79,535	112,062	201,021	99,417	140,080
CHD30-U048001	150,293	74,327	104,727	200,393	99,103	139,640	250,490	123,882	174,550
CHD30-U053001	183,237	90,620	127,760	244,317	120,827	170,250	305,393	151,034	212,811
CHD35-U053001	225,160	111,354	156,901	300,219	148,476	209,203	375,274	185,595	261,504
CHD35-U058001	269,654	133,358	187,904	359,534	177,812	250,539	449,418	222,266	313,170
CHD35-U063001	318,150	157,340	221,698	424,197	209,789	295,590	530,244	262,237	393,339
CHD40-U063001	397,136	196,408	276,739	529,513	261,874	368,983	661,890	327,344	461,226
CHD40-U068001	462,675	228,820	322,406	616,895	305,092	429,874	771,118	381,368	537,345
CHD40-U073001	533,213	263,705	371,561	710,951	351,608	495,415	888,689	439,511	619,269
CHD48-U068001	602,110	311,295	427,589	802,811	414,253	570,117	1,003,523	519,434	712,653
CHD48-U073001	825,358	427,214	586,113	1,100,478	569,616	781,490	1,375,597	712,025	949,312
CHD48-U080001	990,431	512,636	703,339	1,320,563	683,515	937,782	1,650,714	854,393	1,172,240
CHD60-U080001	1,287,531	666,417	914,331	1,716,711	888,559	1,219,113	2,145,887	1,110,693	1,523,894
CHD60-U090001	1,630,021	843,701	1,157,550	2,173,364	1,124,932	1,543,404	2,716,703	1,406,170	1,929,253
CHD60-U100001	2,012,319	1,041,567	1,429,036	2,683,092	1,388,758	1,905,383	3,353,865	1,735,942	2,381,730

SPRING RETURN

Values in in-lbs

MODEL		SPRING TORQUE			AIR TORQUE AIR SUPPLY PRESSURE								
					60 PSI			80 PSI			90 PSI		
		0°	RUN	90°	0°	RUN	90°	0°	RUN	90°	0°	RUN	90°
CHD16-U020*01	A	5,930	4,001	7,151	10,876	4,311	4,556	16,478	7,081	8,462			
	B	7,753	5,231	9,346				14,655	5,851	6,267	20,257	8,622	10,172
CHD16-U025*01	A	9,408	6,346	11,347	16,853	6,642	6,952	25,604	10,967	13,049			
	B	12,356	8,337	14,896				22,656	8,976	9,500	31,407	13,304	15,598
CHD16-U030*01	A	13,241	9,028	16,232	24,573	9,673	10,120	37,176	15,905	18,900			
	B	18,224	12,426	22,339				32,193	12,507	12,793	44,796	18,739	21,576
CHD16-U035*01	A	15,993	11,170	20,348	35,476	14,286	15,516	52,629	22,768	27,472			
	B	22,507	15,356	27,597				46,114	18,582	20,224	63,270	27,064	32,176
CHD25-U035*01	A	18,117	12,957	23,897	44,182	17,854	19,519	64,950	28,126	33,989			
	B	27,375	18,569	33,270				55,692	22,514	24,616	76,460	32,783	39,087
CHD25-U038*01	A	24,419	17,463	32,226	49,020	18,859	18,951	73,503	30,966	36,006			
	B	34,633	23,490	42,103				63,289	24,939	26,128	87,768	37,046	43,190
CHD25-U043*01	A	32,190	21,835	39,129	61,845	24,674	26,401	93,195	40,174	48,243			
	B	44,404	30,119	53,981				80,981	31,890	33,392	112,326	47,394	55,234
CHD30-U043*01	A	41,908	29,561	54,149	78,708	30,092	29,899	118,910	49,974	57,913			
	B	53,972	38,067	69,726				106,847	41,468	42,336	147,049	61,349	70,354
CHD30-U048*01	A	52,104	36,748	67,310	98,188	37,579	37,417	148,289	62,354	72,330			
	B	68,629	48,405	88,658				131,764	50,698	50,982	181,861	75,477	85,892
CHD30-U053*01	A	62,265	43,917	80,436	120,972	46,703	47,248	182,052	76,910	89,814			
	B	81,577	57,548	105,395				162,739	63,279	64,855	223,816	93,486	107,417
CHD35-U053*01	A	78,365	54,777	99,890	146,795	56,577	57,011	221,855	93,699	109,313			
	B	104,173	72,886	132,921				196,046	75,590	76,282	271,101	112,709	128,584
CHD35-U058*01	A	90,233	63,132	115,131	179,420	70,226	72,774	269,301	114,680	135,409			
	B	127,052	88,897	162,110				232,482	88,915	88,429	322,366	133,369	151,060
CHD35-U063*01	A	108,793	76,125	138,815	209,357	81,215	82,883	315,404	133,663	156,775			
	B	143,010	100,067	182,476				281,187	109,722	113,114	387,234	162,170	187,014
CHD40-U063*01	A	128,159	91,092	167,527	268,977	105,316	109,212	401,354	170,782	201,456			
	B	167,872	124,158	233,084				361,641	137,716	135,898	494,018	203,186	228,142
CHD40-U068*01	A	156,791	111,440	204,948	305,884	117,380	117,458	460,104	193,652	224,926			
	B	195,734	144,772	271,789				421,160	160,321	158,085	575,383	236,596	265,556
CHD40-U073*01	A	176,944	125,760	231,288	356,269	137,944	140,274	534,007	225,848	264,127			
	B	221,525	163,845	307,590				489,426	187,763	187,825	667,163	275,666	311,679
CHD48-U068*01	A	232,934	160,092	337,789	369,176	151,202	89,800	569,877	254,161	232,329			
	B	302,819	208,125	439,139				499,992	206,128	130,979	700,703	311,309	273,514
CHD48-U073*01	A	319,300	219,454	463,044	506,059	207,760	123,069	781,178	350,162	318,445			
	B	415,091	285,286	601,948				685,387	284,330	179,542	960,506	426,739	347,364
CHD48-U080*01	A	383,149	263,336	555,632	607,282	249,300	147,707	937,414	420,179	382,150			
	B	498,093	342,338	722,327				822,470	341,177	215,455	1,152,620	512,055	449,912
CHD60-U080*01	A	498,111	342,347	722,345	789,420	324,070	191,994	1,218,600	546,212	496,768			
	B	647,556	445,060	939,073				1,069,155	443,499	280,040	1,498,331	665,633	584,821
CHD60-U090*01	A	630,607	433,412	914,494	999,414	410,289	243,056	1,542,757	691,520	628,909			
	B	819,800	563,438	1,188,850				1,353,564	561,493	354,554	1,896,903	842,732	740,403
CHD60-U100*01	A	778,529	535,072	1,129,001	1,233,790	506,495	300,035	1,904,563	853,686	776,382			
	B		695,580	1,467,666				1,671,027	693,178	437,717	2,341,800	1,040,362	914,064

* = spring type A or B in the model number indicates the selection of either the "A" or "B" spring from the table above.

OVERALL DIMENSIONS

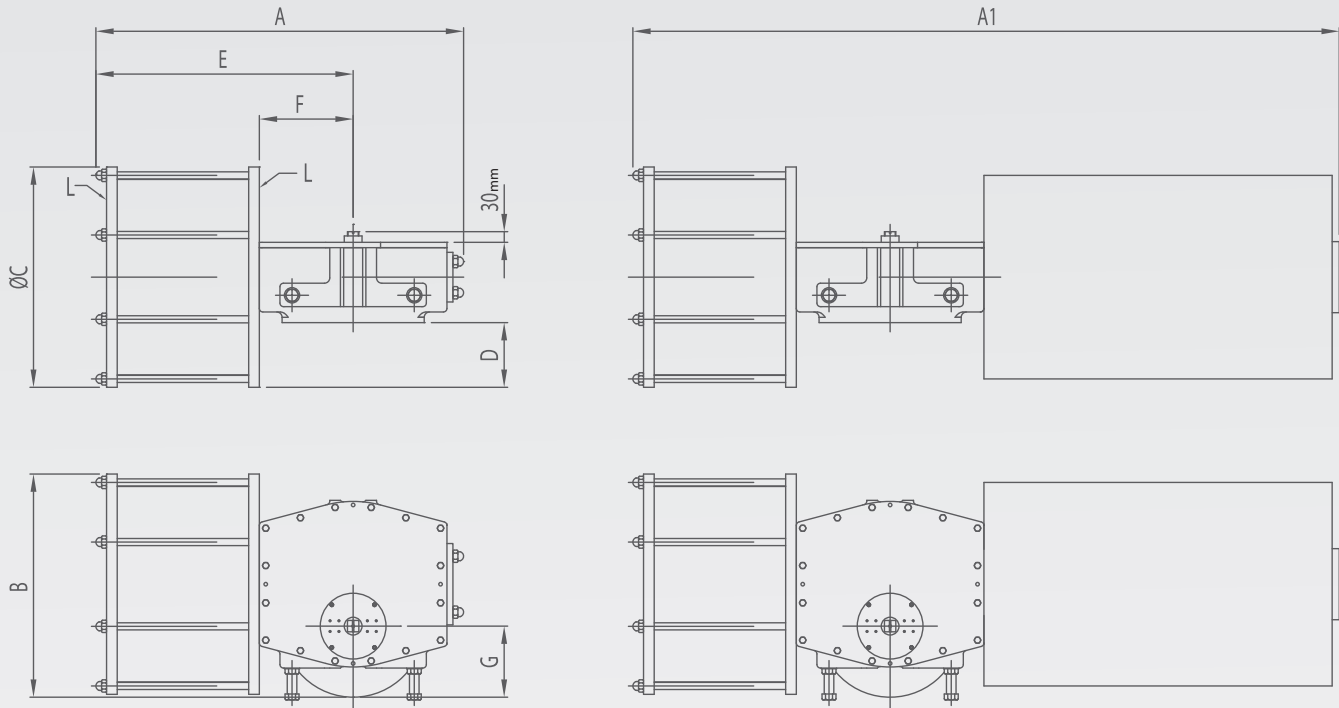

MODEL	OVERALL DIMENSIONS (INCHES)									WEIGHTS (LBS)	
	A	A1	B	C	D	E	F	G	L	DA	SR
(S)HD16-U020***	31.5	52.2	14.6	10.7	1.89	20.3	7.72	5.71	1/2" NPT	198	298
(S)HD16-U025***	31.5	52.2	15.6	12.7	2.87	20.3	7.72	5.71	1/2" NPT	243	353
(S)HD16-U030***	31.5	52.2	16.5	14.7	3.86	20.3	7.72	5.71	1/2" NPT	287	408
(S)HD16-U035***	31.5	52.2	17.5	16.1	4.61	20.3	7.72	5.71	1/2" NPT	342	496
(S)HD25-U035***	38.8	59.4	19.3	16.1	3.62	25.7	9.29	6.89	3/4" NPT	452	694
(S)HD25-U038***	38.8	59.4	19.9	18.1	4.65	25.7	9.29	6.89	3/4" NPT	485	761
(S)HD25-U043***	38.8	59.4	20.9	20.2	5.63	25.7	9.29	6.89	3/4" NPT	551	849
(S)HD30-U043***	47.8	76.2	25.2	20.2	5.04	30.0	11.3	7.48	1" NPT	683	1080
(S)HD30-U048***	47.8	76.2	25.9	22.2	6.02	30.0	11.3	7.48	1" NPT	750	1213
(S)HD30-U053***	47.8	76.2	26.9	24.6	7.24	30.0	11.3	7.48	1" NPT	827	1411
(S)HD35-U053***	56.5	91.3	28.0	24.6	6.18	35.6	13.5	9.06	1" NPT	1323	1984
(S)HD35-U058***	56.5	91.3	28.8	26.6	7.20	35.6	13.5	9.06	1" NPT	1411	2249
(S)HD35-U063***	56.5	91.3	29.9	28.7	8.27	35.6	13.5	9.06	1" NPT	1499	2513
(S)HD40-U063***	67.3	108.3	32.7	29.3	7.56	44.3	16.3	10.2	1-1/4" NPT	2161	3527
(S)HD40-U068***	67.3	108.3	33.5	31.3	8.54	44.3	16.3	10.2	1-1/4" NPT	2271	3792
(S)HD40-U073***	67.3	108.3	34.4	33.3	9.57	44.3	16.3	10.2	1-1/4" NPT	2403	4079

Note: SHD & CHD series overall dimensions are the same.

A1 Max overall length given for B spring configurations

DA is for double acting, SR is for spring return w/ B-Spring.

FLANGE CONNECTION

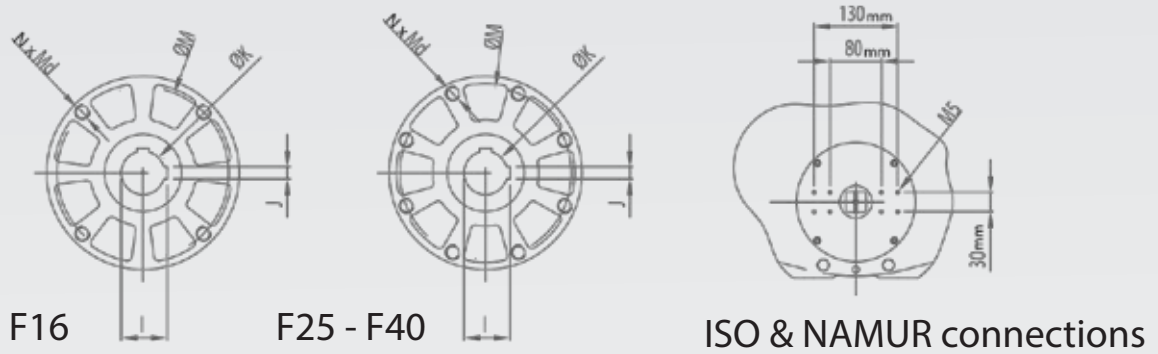

Dimensions in inches

CONNECTING DIMENSIONS												
MODEL	BOLT CIRCLE					BORE+KEY	KEY	MAIN BORE				
	ØM	N	Md		Depth	ISO	I	J	ØK	Depth		
(S)HD16-U020***	6.50	4	M20		0.98	F16	2.13	0.551	1.969	6.14		
(S)HD16-U025***	6.50	4	M20		0.98	F16	2.13	0.551	1.969	6.14		
(S)HD16-U030***	6.50	4	M20		0.98	F16	2.13	0.551	1.969	6.14		
(S)HD16-U035***	6.50	4	M20		0.98	F16	2.13	0.551	1.969	6.14		
(S)HD25-U035***	10.00	11.73	8	M16	M20	1.06	F25	F30	3.35	0.787	3.150	8.03
(S)HD25-U038***	10.00	11.73	8	M16	M20	1.06	F25	F30	3.35	0.787	3.150	8.03
(S)HD25-U043***	10.00	11.73	8	M16	M20	1.06	F25	F30	3.35	0.787	3.150	8.03
(S)HD30-U043***	11.73	14.02	8	M20	M30	1.34	F30	F35	4.58	1.102	4.331	9.21
(S)HD30-U048***	11.73	14.02	8	M20	M30	1.34	F30	F35	4.58	1.102	4.331	9.21
(S)HD30-U053***	11.73	14.02	8	M20	M30	1.34	F30	F35	4.58	1.102	4.331	9.21
(S)HD35-U053***	14.02	8	M30		1.69	F35	5.41	1.260	5.118	10.98		
(S)HD35-U058***	14.02	8	M30		1.69	F35	5.41	1.260	5.118	10.98		
(S)HD35-U063***	14.02	8	M30		1.69	F35	5.41	1.260	5.118	10.98		
(S)HD40-U063***	15.98	8	M36		2.09	F40	6.20	1.260	5.906	12.83		
(S)HD40-U068***	15.98	8	M36		2.09	F40	6.20	1.260	5.906	12.83		
(S)HD40-U073***	15.98	8	M36		2.09	F40	6.20	1.260	5.906	12.83		

Note: SHD & CHD series mounting dimensions are the same.



The Best Way To Automate Your Process

Your nearest Max-Air dealer can be found at:



NORTH AMERICA
Max-Air Technology, Inc.
751 Hoff Rd
O'Fallon, Missouri 63366
United States of America
Tel: +1.636.272.4934
Toll Free: 888.842.9998
Fax: 636.272.4937

EUROPE
Emme Technology, Srl.
Via Di Vittorio, 307/27
20099 Sesto San Giovanni
Milan, Italy
Tel: +39.02.2626.2174
Fax: +39.02.2622.0777

ASIA
Max-Air Technology, Co. Ltd
Room 606, Tongyuan Building No.68
Tongyuanju Front Street,
Jinan 250012
China
Tel: +86.531.86917039
Fax: +86.531.86917039

Our Website:



R02262016