

MT61 F10+F12
TECHNICAL DATA

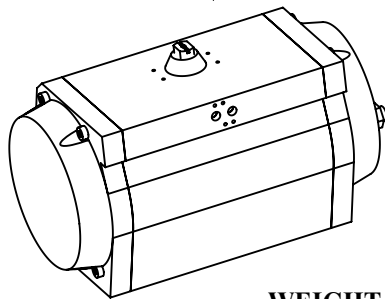

DIMENSIONS TO
ISO 5211 - DIN 3337
AND NAMUR VDI/VDE 3845

DIMENSIONS IN INCHES

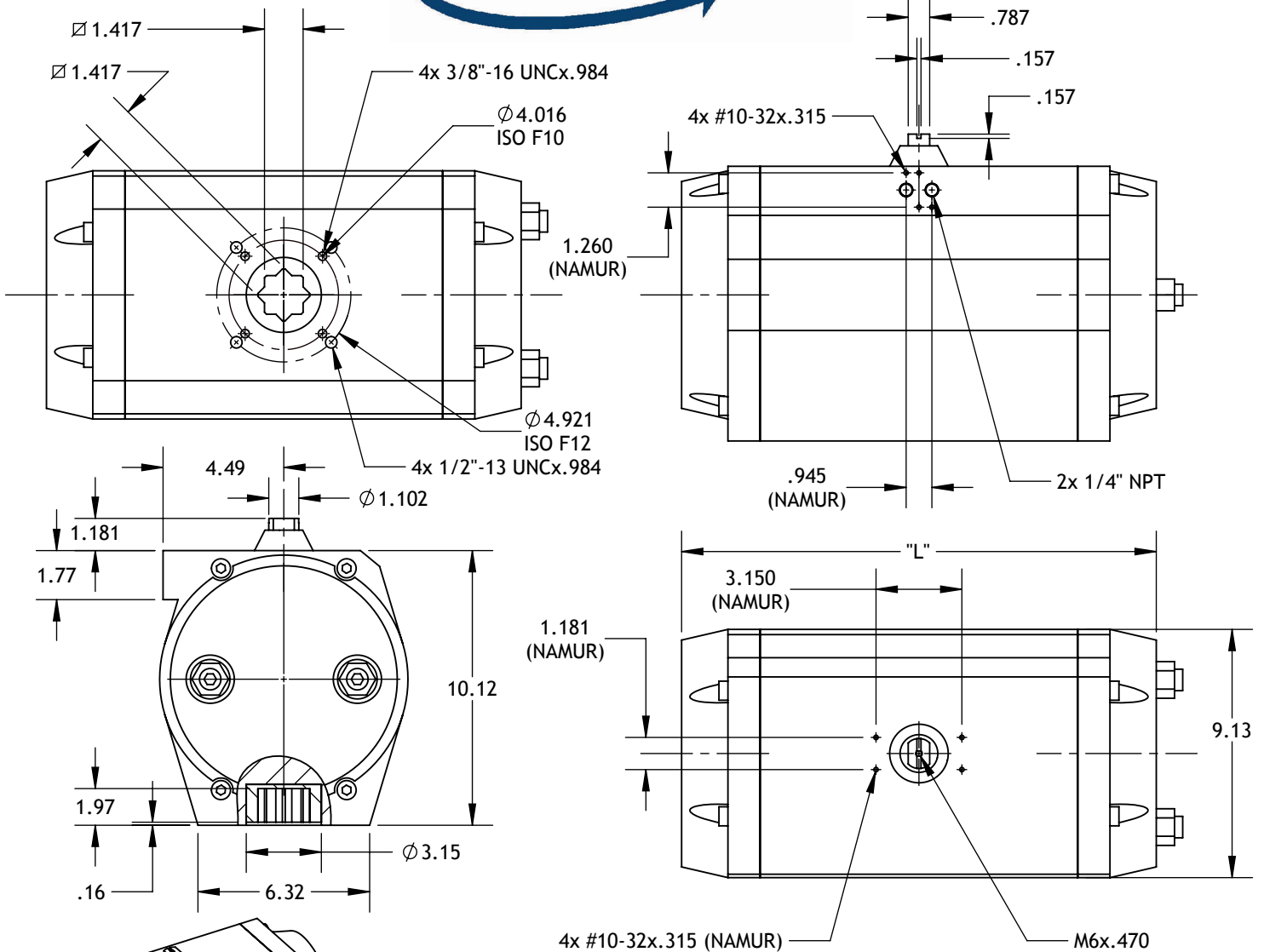

WEIGHT

STROKE	DOUBLE ACTING					SPRING RETURN 7+5 SPRING
	90°	120°	135°	150°	180°	90°
LB.	61.5	CALL	CALL	CALL	CALL	83.1

	90°	120°	135°	150°	180°
"L"	17.480	19.882	21.142	22.480	24.291

AIR CONSUMPTION (FULL CYCLE)

STROKE	DOUBLE ACTING					SPRING RETURN 7+5 SPRING
	90°	120°	135°	150°	180°	90°
CU.-IN.	881.3	1056.3	1143.8	1231.3	1406.3	343.8

Max-Air Technology Inc.

751 Hoff Road - O'Fallon, Missouri 63366 U.S.A.
www.max-airtechnology.com info@max-airtechnology.com