

MT12-F04
TECHNICAL DATA

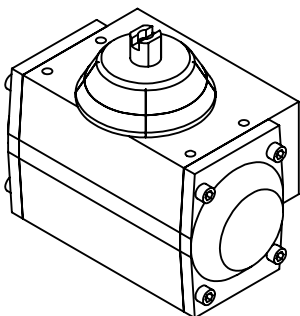

MT05-F04
DATI TECNICI

DIMENSIONS TO
ISO 5211 - DIN 3337
AND NAMUR VDI/VDE 3845
DIMENSIONS IN INCHES
[MM]

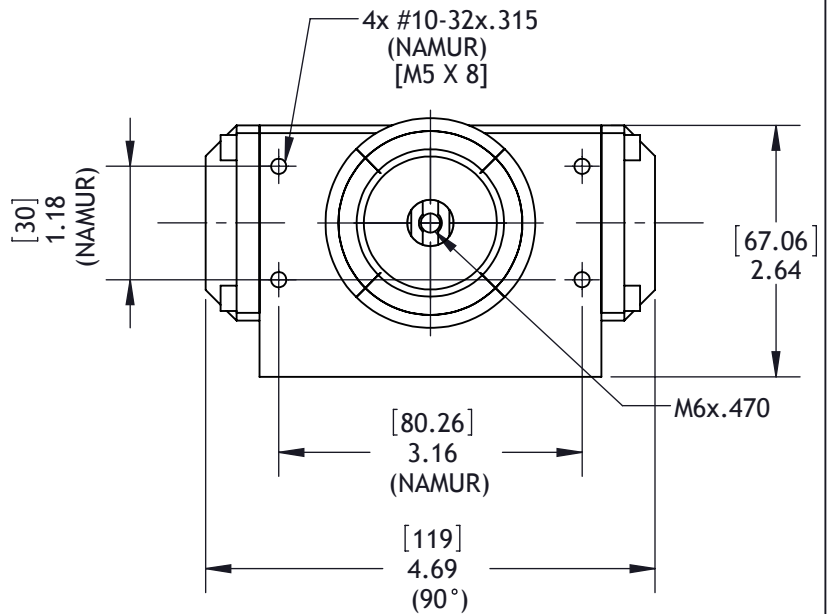
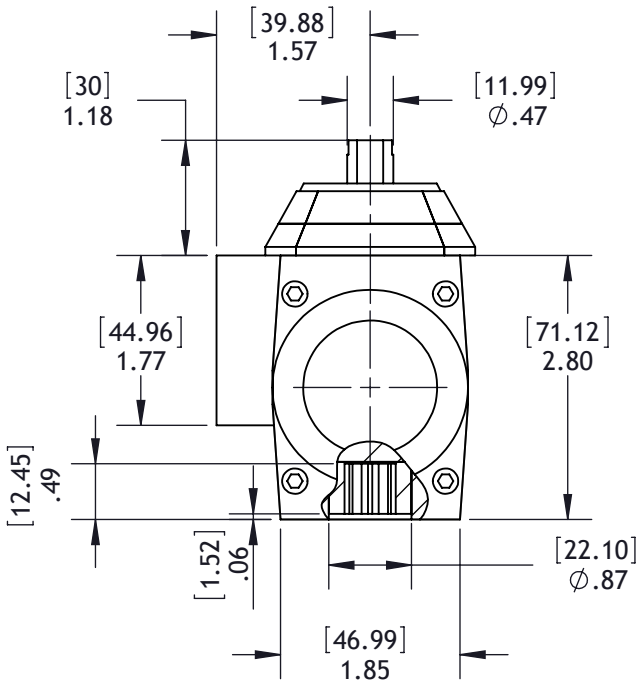
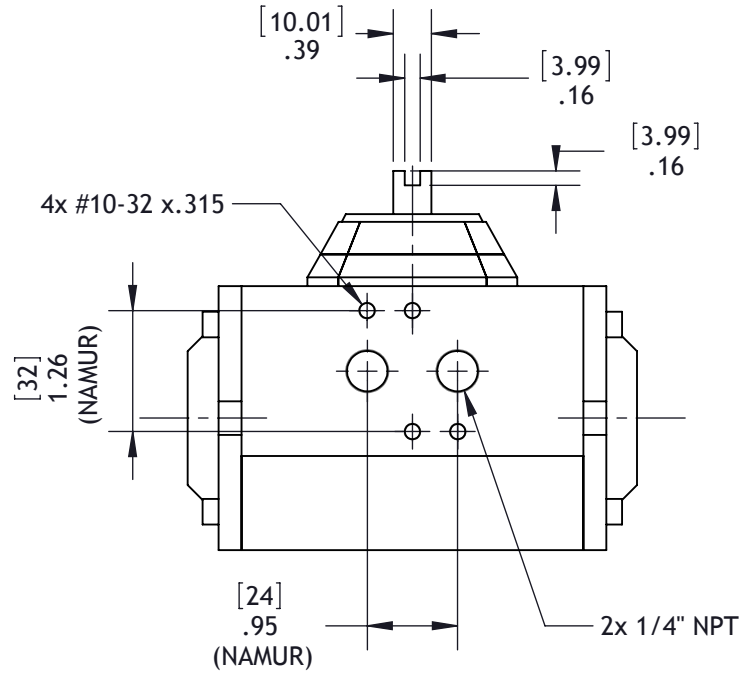
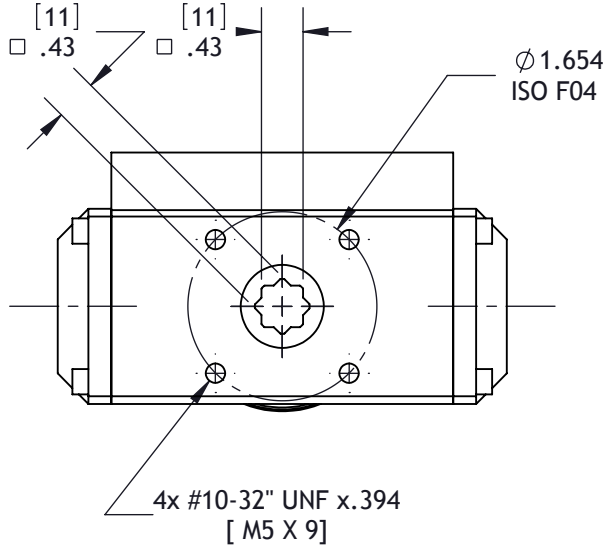

WEIGHT IN L.B.		AIR CONSUMPTION IN CU. IN.	
D.A.	S.R.	D.A.	S.R.
2.00	2.18	13.50	8.00

MT-05

VALORI DI COPPIA IN Nm TORQUE VALUES IN Nm

DOPPIO EFFETTO 90° DOUBLE ACTING 90°

100 kPa = 1 Bar

100 kPa	200 kPa	300 kPa	400 kPa	500 kPa	562 kPa	600 kPa	700 kPa	800 kPa	900 kPa	1000 kPa
2,52	5,0	7,6	10,1	12,6	14,1	15,1	17,6	20,2	22,7	25,2

SEMPLICE EFFETTO 90° SPRING RETURN 90°

100 kPa = 1 Bar

POS. 1
COPPIA DI CHIUSURA
(RITORNO MOLLE)

POS. 1
CLOSING TORQUE
(SPRING)

POS. 2 - COPPIA DI APERTURA - POS. 2 - OPENING TORQUE

N° MOLLE # SPRINGS	POS. 1 CLOSING TORQUE (SPRING)		200 kPa		300 kPa		400 kPa		500 kPa		562 kPa		600 kPa		700 kPa		800 kPa		900 kPa		1000 kPa	
	START	END	START	END	START	END	START	END	START	END	START	END	START	END	START	END	START	END	START	END	START	END
1+1	3,7	2,5	2,5	1,3	5,1	3,9	7,6	6,4	10,1	8,9	11,6	10,4	12,6	11,4	15,1	13,9	17,7	16,5	20,2	19,0	22,7	21,5
2+2	7,4	5,0	--	--	2,6	0,2	5,1	2,7	7,6	5,2	9,1	6,7	10,1	7,7	12,6	10,2	15,2	12,8	17,7	15,3	20,2	17,8
3+3	11,2	7,5	--	--	--	--	--	--	5,1	1,5	6,6	3,0	7,6	4,0	10,1	6,5	12,7	9,1	15,2	11,5	17,7	14,0

MT-12

TORQUE VALUES IN IN. Lb.

SPRING RETURN 90°

DOUBLE ACTING 90°

40 PSIG	60 PSIG	80 PSIG	100 PSIG	120 PSIG
62	94	125	156	187

# SPRINGS	POS. 1 CLOSING TORQUE (SPRING)		POS. 2 - OPENING TORQUE									
	START	END	40 PSIG		60 PSIG		80 PSIG		100 PSIG		120 PSIG	
1+1	33	22	40	29	72	61	103	92	134	123	165	154
2+2	66	44	--	--	50	28	81	59	112	90	143	121
3+3	99	66	--	--	--	--	58	27	90	66	121	88

PESI - WEIGHT

DOPPIO EFFETTO = 0,850 Kg.
DOUBLE ACTING = 1.87 LB.

SEMPLICE EFFETTO (3+3 molle) = 0,935 Kg.
SPRING RETURN (3+3 spring) = 2.06 LB.

CONSUMI ARIA (CICLO COMPLETO) AIR CONSUMPTION (FULL CYCLE)

DOPPIO EFFETTO = 0,22 N. Lt.
DOUBLE ACTING = 13.5 CU. IN.

SEMPLICE EFFETTO (3+3 molle) = 0,13 N. Lt.
SPRING RETURN (3+3 spring) = 8.0 CU. IN.

