



Heavy Duty Gear Operators w/ Options

Max-Air Technology offers two primary types of gear operators for use with quarter-turn valves; a manual gear, and a declutchable gear. Both types are designed with a broad output torque range, and are generally designed for use with ISO 5211 valve mounting interfaces, but not required. For the declutchable gear, an ISO 5211 interface is standard for the actuator and valve connections. Both units come standard with a female double square output drive, which directly couples to square valve stems, or quickly adapts to smaller square drives, or double-D and keyed drives with the use of adapter bushings.

Standard Features:

- Direct ISO 5211 standard valve mounting
- Compact Design
- ISO Valve Connection (Double Square)
- Durable Epoxy Coating
- Wide temperature range w/ corresponding high/low temperature gaskets and grease



GO Series Manual Gear

Direct ISO 5211 valve mounting for easy and compact handwheel operation.



GOW Series Declutchable

Declutchable override gear with triple epoxy coated IP67 housing mounts between ISO 5211 valve and actuator interfaces. Features an easy declutch mechanism, integrated block and bleed capability and lockout/tagout holes.

| | |
|---------------------|---|
| Torque Range | See Selection Guide Below |
| Rotation | 90 ±5° Degrees |
| Ambient Temp. Range | -4°F to 176°F Standard/ -40°F Low/ +248°F High |

| | |
|-------------------|---------------------------|
| Mounting | ISO 5211 |
| Materials | WCB, Cast Iron |
| Available Options | See Selection Guide Below |

Gear Operator Series Selection

Start from the top of the chart and work down to select the correct Gear Operator Series.

| Type | Manual Operation | | Declutchable Operation | |
|----------------------------|--|--------------------------|--|---------------------------|
| Torque | Up to 885,000 in-lbs | | Up to 61,955 in-lbs | |
| Environment | Standard | | Standard & Corrosive | |
| Temperature | Standard | Extreme (High/Low) | Standard | Extreme (High/Low) |
| Recommended Series/Options | GO Series | GO Series w/ Temp. Seals | GOW Series | GOW Series w/ Temp. Seals |
| Features | N/A | | Lockout Plate Standard Integrated Block & Bleed | |
| Available Options | Chain Wheel Operators Stem Extensions Square Operating Nuts Custom Size Handwheel Limit Switch Mounting Kits Optional Lockout Plate | | Custom Size Handwheel | |

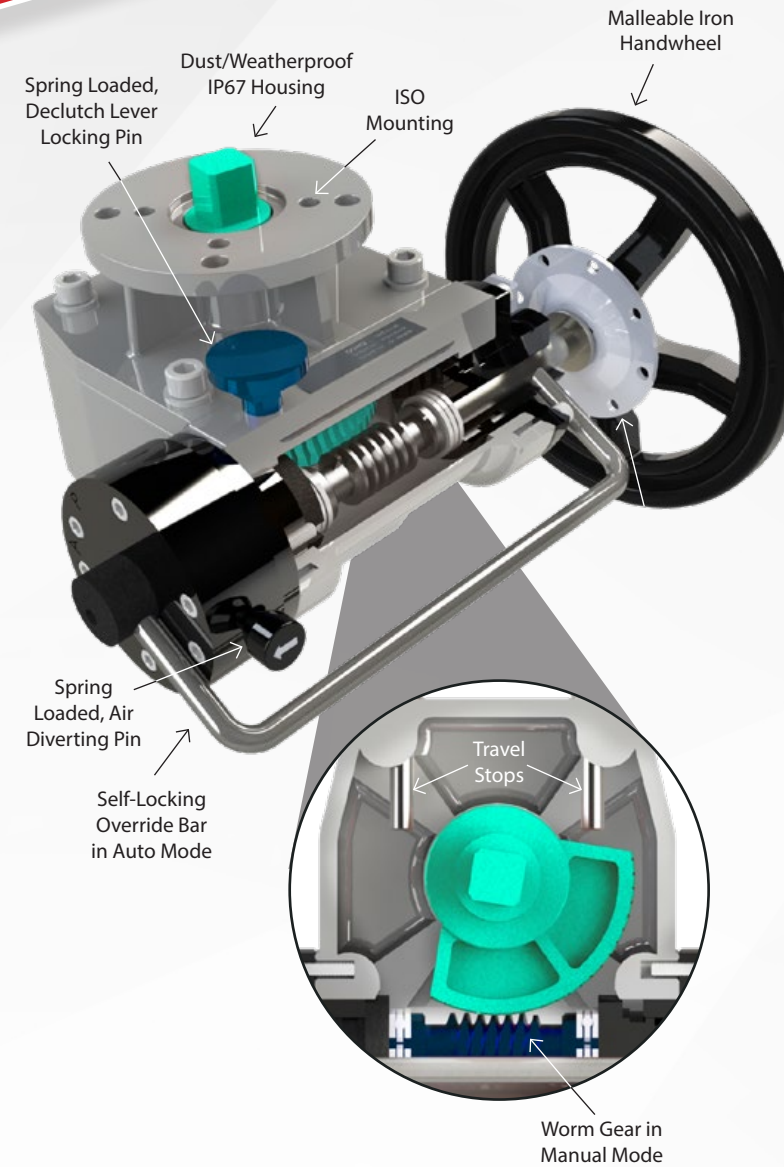

GOW Series Declutchable

Max-Air offers a declutchable override gear with triple epoxy coated IP67 housing mounts between ISO 5211 valve and actuator interfaces. It features an easy declutch mechanism, integrated block and bleed capability and lockout/tagout holes. GOW Series comes standard with a female double square output drive, which directly couples to square valve stems, or quickly adapts to smaller square drives, or double-D and keyed drives with the use of adapter bushings.

| Seals | Temperature Range |
|--------------------|-------------------------------|
| Standard (BUNA-N) | -4°F (-20°C) to 176°F (80°C) |
| High Temp. (FKM) | 5°F (-15°C) to +248°F (120°C) |
| Low Temp. (BUNA-N) | -40°F (-40°C) to 176°F (80°C) |

Integrated Block & Bleed Air Tubing GOW Series includes an integrated block & bleed valve triggered by the clutching mechanism which can be used. If using a separate block & bleed device, please follow manufacturer's instructions. Air tubing from integrated block & bleed valve to actuator air ports should be as follows. If not using, leave ports plugged or install dust screens/filters.

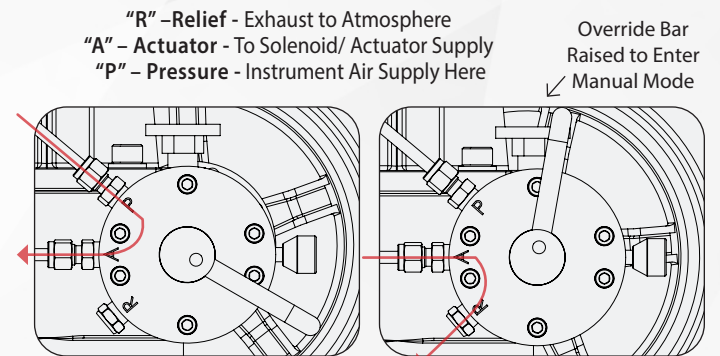

Auto Mode Pressurized supply air flows freely into "P" port and out "A" port to the Actuator/Solenoid.

Manual Mode Pressurized supply air flow is blocked at "P" port. Air exhausts from the actuator/solenoid "A" port through "R" port to atmosphere.

GO Series Manual

Direct ISO 5211 valve mounting for easy and compact handwheel operation. The GO Series comes standard with a female double square output drive, which directly couples to square valve stems, or quickly adapts to smaller square drives, or double-D and keyed drives with the use of adapter bushings.

| Seals | Temperature Range |
|----------------------|-------------------------------|
| Standard (BUNA-N) | -4°F (-20°C) to 176°F (80°C) |
| High Temp. (FKM) | 5°F (-15°C) to +248°F (120°C) |
| Low Temp. (Silicone) | -40°F (-40°C) to 176°F (80°C) |

