

Part Number	A	B	C	D	L
SSQ.11 X 9 ADAPTER	0.354	0.433	0.484	0.563	0.472
SSQ.14 X 9 ADAPTER	0.354	0.551	0.484	0.709	0.591
SSQ.14 X 11 ADAPTER	0.433	0.551	0.563	0.709	0.591
SSQ.17 X 9 ADAPTER	0.354	0.669	0.484	0.866	0.669
SSQ.17 X 11 ADAPTER	0.433	0.669	0.563	0.866	0.669
SSQ.17 X 13 ADAPTER	0.512	0.669	0.681	0.866	0.669
SSQ.17 X 14 ADAPTER	0.551	0.669	0.720	0.866	0.669
SSQ.22 X 9 ADAPTER	0.354	0.866	0.484	1.102	0.823
SSQ.22 X 11 ADAPTER	0.433	0.866	0.563	1.102	0.823
SSQ.22 X 14 ADAPTER	0.551	0.866	0.720	1.102	0.823
SSQ.22 X 15.5 ADAPTER	0.610	0.866	0.809	1.102	0.823
SSQ.22 X 16 ADAPTER	0.630	0.866	0.839	1.102	0.866
SSQ.22 X 17 ADAPTER	0.669	0.866	0.878	1.102	0.866
SSQ.22 X 19 ADAPTER	0.748	0.866	0.996	1.102	0.823
SSQ.27 X 11 ADAPTER	0.433	1.063	0.563	1.417	1.063
SSQ.27 X 14 ADAPTER	0.551	1.063	0.720	1.417	1.063
SSQ.27 X 19 ADAPTER	0.748	1.063	0.996	1.417	1.063
SSQ.27 X 22 ADAPTER	0.866	1.063	1.122	1.417	1.063
SSQ.27 X 24 ADAPTER	0.945	1.063	1.224	1.417	1.141
SSQ.36 X 17 ADAPTER	0.669	1.417	0.878	1.772	1.457
SSQ.36 X 19 ADAPTER	0.748	1.417	0.996	1.772	1.417
SSQ.36 X 22 ADAPTER	0.866	1.417	1.122	1.772	1.417
SSQ.36 X 27 ADAPTER	1.063	1.417	1.421	1.772	1.417
SSQ.46 X 27 ADAPTER	1.063	1.811	1.421	2.264	1.929
SSQ.46 X 36 ADAPTER	1.417	1.811	1.543	2.264	1.929

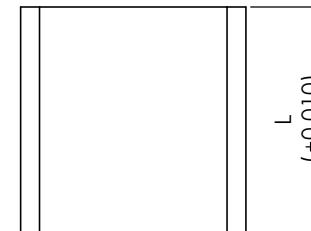
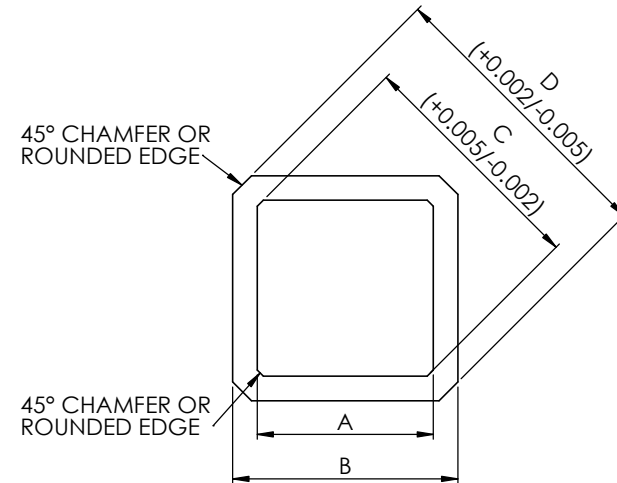

B

A

"A" TOLERANCE		
Width Range (inches)	Oversize (in)	
	Min	Max
0.125 - 0.250	+0.001	+0.004
0.251 - 0.500	+0.001	+0.005
0.501 - 0.750	+0.001	+0.006
0.751 - 1.000	+0.001	+0.006
1.001 - 1.500	+0.002	+0.007
1.501 - 2.000	+0.002	+0.008

"B" TOLERANCE (inches)			
Size	Min	Max	
0.354	0.349	0.354	
0.433	0.428	0.433	
0.551	0.546	0.551	
0.669	0.664	0.669	
0.866	0.861	0.866	
1.063	1.058	1.063	
1.417	1.412	1.417	
1.811	1.806	1.811	

	NAME	DATE
DRAWN	EMK	7-26-23
CHECKED		
ENG APPR.		
MFG APPR.		

**PROPRIETARY AND CONFIDENTIAL**  
 THE INFORMATION CONTAINED IN THIS DRAWING IS THE SOLE PROPERTY OF MAX-AIR TECHNOLOGY, INC. ANY REPRODUCTION IN PART OR AS A WHOLE WITHOUT THE WRITTEN PERMISSION OF MAX-AIR TECHNOLOGY, INC. IS PROHIBITED.



Max-Air Technology, Inc.  
 114 Resource Dr.  
 Wentzville, MO 63385  
 (888) 842-9998  
 www.maxairtech.com

TITLE: MASTER DRAWING FOR SSSQ TO SSQ ADAPTERS

SIZE	DWG. NO.	REV
<b>B</b>	SSQ-SSQ_MASTER_Drawing	0
SCALE: 1:1	WEIGHT:	SHEET 1 / 1