

# SE A004 HW 3ph | Open/Close

Overview, Specifications, Dimensional Data, Materials of Construction, Wiring Diagrams



## SE A004 HW 3ph Series Open/Close



## Overview

The 3 phase SE A004 HW Series are spring return, quarter-turn electric industrial service actuators delivering up to 445 in-lbs torque in voltages ranging from 220/3 up through 460/3, and are available in 2 position (Open/Close) control schemes. (2) Form C auxiliary switches and an internal anti-condensate heater are standard. Key features include:

- 3 Phase models operate on 50 or 60 Hz supplies
- 3D Raised Position indicator
- ISO5211 compliant mounting with double-square drive socket
- Spring CW (standard) fail-safe positioning
- Handwheel manual override
- IP68 standard

### Options

- Spring CCW fail-safe positioning
- Low Voltage and single phase also available
- Local Control Stations

## Specifications

		SETA004 HW 3PH
Supply	Torque Output (in-lb / Nm)	445 in-lb / 50 Nm
220/3	Starting Current (A) DC/60Hz/50Hz	- / 1.1 / 1.1
	Running Current (A) DC/60Hz/50Hz	- / 0.5 / 0.6
	Speed (90°) sec @ rated load - DC/60Hz/50Hz	- / 8 / 9
	Speed (90°) sec @ spring return	5
	Motor Power	50 Watts
	Duty Cycle	100% (EN 60034) Class A (ISO 22153)
380/3	Starting Current (A) DC/60Hz/50Hz	- / 0.7 / 0.7
	Running Current (A) DC/60Hz/50Hz	- / 0.3 / 0.4
	Speed (90°) sec @ rated load - DC/60Hz/50Hz	- / 8 / 9
	Speed (90°) sec @ spring return	5
	Motor Power	50 Watts
	Duty Cycle	100% (EN 60034) Class A (ISO 22153)
460/3	Starting Current (A) DC/60Hz/50Hz	- / 0.4 / 0.5
	Running Current (A) DC/60Hz/50Hz	- / 0.2 / 0.3
	Speed (90°) sec @ rated load - DC/60Hz/50Hz	- / 8 / 9
	Speed (90°) sec @ spring return	5
	Motor Power	50 Watts
	Duty Cycle	100% (EN 60034) Class A (ISO 22153)
ALL	Environmental Rating	NEMA 4/4X & IP68
	Electrical Entry	3/4" EMT x 2
	Control	Open/Close
	Auxiliary Switch - End of Travel	(2) Form C Volt-Free, Rated 10A @ 250vac, 5A @ 30VDC
	Ambient Operating Range	-40°F ~ 149°F (-40°C ~ 65°C)
	Humidity Range	0-95% RH
	Altitude Limit	9850 ft / 3000 m
	Weight (kg / lbs)	37 kg / 82#

\* Models weighing over 32 kg / 70lbs must be shipped by Truck

# SE A004 HW 3ph | 3ph | Open/Close

Overview, Specifications, Dimensional Data, Materials of Construction, Wiring Diagrams

## Dimensional Drawing

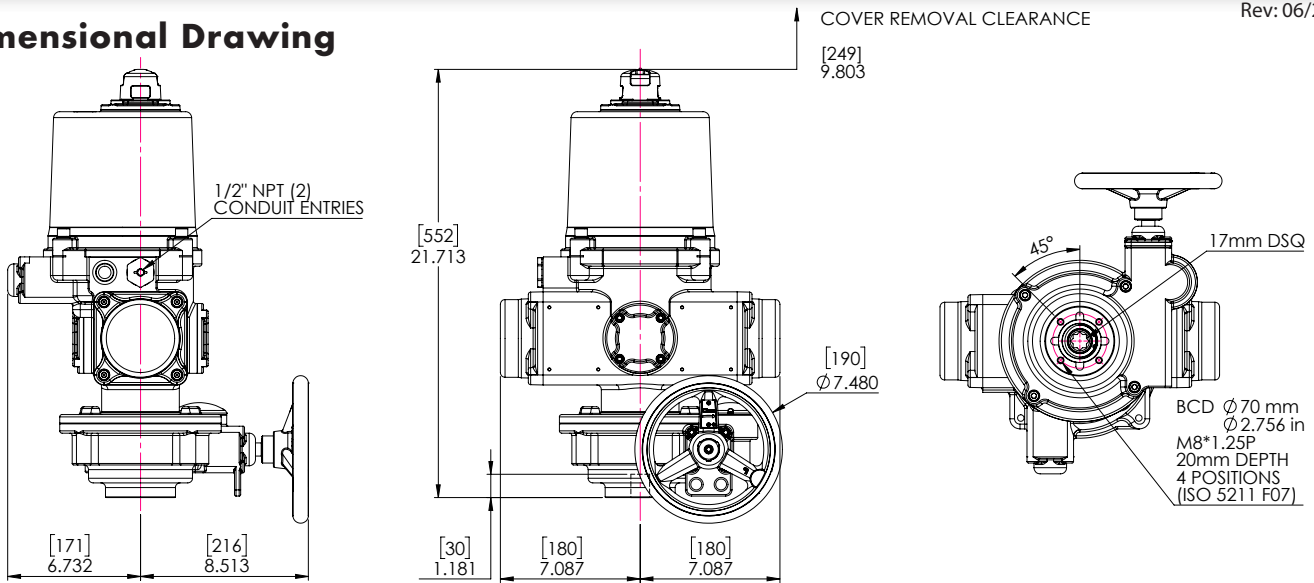

Rev: 06/21/22



Website

## Materials of Construction

#	DESCRIPTION	MATERIALS
1	Actuator	ADC3 Aluminum Alloy
2	Indicator	Transparent ABS
3	Cover Screw (x4)	SUS304
4	2nd EMT Port Seal	Polyamide
5	Cover Seal	NBR O-Ring
6	ISO Mount Profiles	ADC3 Aluminum Alloy
7	Output Socket	FDC60 Graphite Iron
8	Handwheel	Nylon PA6

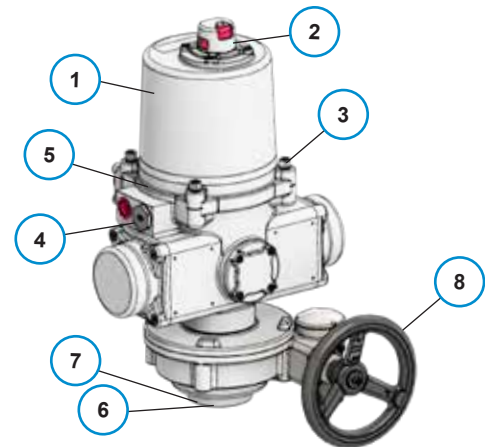

## Wiring Diagrams

Typical wiring diagram shown.

Max-Air reserves the right to change specifications through a continuous-improvement program.

Contact Max-Air for product specific wiring diagrams prior to engineering or installation efforts.

Open/Close

