

SE B011 HW 3ph | Open/Close

Overview, Specifications, Dimensional Data, Materials of Construction, Wiring Diagrams



SE B011 HW 3ph Series Open/Close



Overview

The 3 phase SE B011 HW Series are spring return, quarter-turn electric industrial service actuators delivering up to 1150 in-lbs torque in voltages ranging from 220/3 up through 460/3, and are available in 2 position (Open/Close) control schemes. (2) Form C auxiliary switches and an internal anti-condensate heater are standard. Key features include:

- 3 Phase models operate on 50 or 60 Hz supplies
- 3D Raised Position indicator
- ISO5211 compliant mounting with double-square drive socket
- Spring CW (standard) fail-safe positioning
- Handwheel manual override
- IP68 standard

Options

- Spring CCW fail-safe positioning
- Low Voltage and single phase also available
- Local Control Stations

Specifications

| | | SETB011 HW 3PH |
|--------|---|--|
| Supply | Torque Output (in-lb / Nm) | 1150 in-lb / 130 Nm |
| 220/3 | Starting Current (A) DC/60Hz/50Hz | - / 2.1 / 2.1 |
| | Running Current (A) DC/60Hz/50Hz | - / 0.8 / 0.9 |
| | Speed (90°) sec @ rated load - DC/60Hz/50Hz | - / 8 / 9 |
| | Speed (90°) sec @ spring return | 7 |
| | Motor Power | 130 Watts |
| | Duty Cycle | 100% (EN 60034) Class A (ISO 22153) |
| 380/3 | Starting Current (A) DC/60Hz/50Hz | - / 1.2 / 1.3 |
| | Running Current (A) DC/60Hz/50Hz | - / 0.5 / 0.5 |
| | Speed (90°) sec @ rated load - DC/60Hz/50Hz | - / 8 / 9 |
| | Speed (90°) sec @ spring return | 8 |
| | Motor Power | 130 Watts |
| | Duty Cycle | 100% (EN 60034) Class A (ISO 22153) |
| 460/3 | Starting Current (A) DC/60Hz/50Hz | - / 1.4 / 1.5 |
| | Running Current (A) DC/60Hz/50Hz | - / 0.5 / 0.6 |
| | Speed (90°) sec @ rated load - DC/60Hz/50Hz | - / 8 / 9 |
| | Speed (90°) sec @ spring return | 8 |
| | Motor Power | 130 Watts |
| | Duty Cycle | 100% (EN 60034) Class A (ISO 22153) |
| ALL | Environmental Rating | NEMA 4/4X & IP68 |
| | Electrical Entry | 3/4" EMT x 2 |
| | Control | Open/Close |
| | Auxiliary Switch - End of Travel | (2) Form C Volt-Free, Rated 10A @ 250vac, 5A @ 30VDC |
| | Ambient Operating Range | -40°F ~149°F (-40°C~65°C) |
| | Humidity Range | 0-95% RH |
| | Altitude Limit | 9850 ft / 3000 m |
| | Weight (kg / lbs) | 74.5 kg / 164# |

* Models weighing over 32 kg / 70lbs must be shipped by Truck

SE B011 HW 3ph | Open/Close

Overview, Specifications, Dimensional Data, Materials of Construction, Wiring Diagrams



Website

Dimensional Drawing

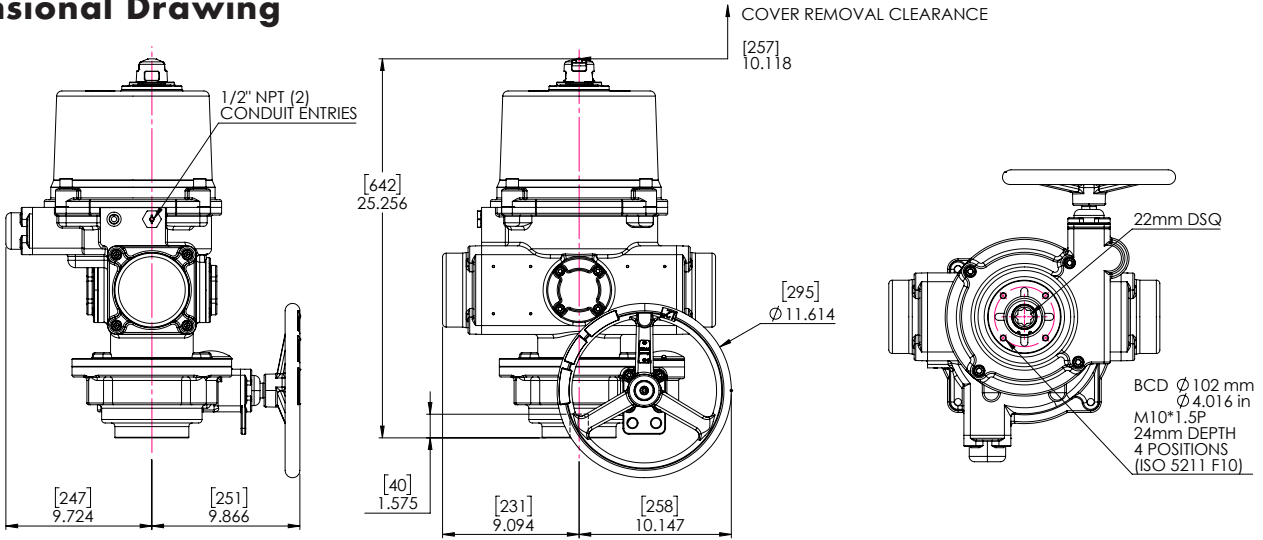

Materials of Construction

| # | DESCRIPTION | MATERIALS |
|---|--------------------|-----------------------------|
| 1 | Actuator | ADC3 Aluminum Alloy |
| 2 | Indicator | Transparent ABS |
| 3 | Cover Screw (x4) | SUS304 |
| 4 | 2nd EMT Port Seal | Polyamide |
| 5 | Cover Seal | NBR O-Ring |
| 6 | ISO Mount Profiles | ADC3 Aluminum Alloy |
| 7 | Output Socket | FDC60 Graphite Iron |
| 8 | Handwheel | Epoxy Coated Aluminum Alloy |

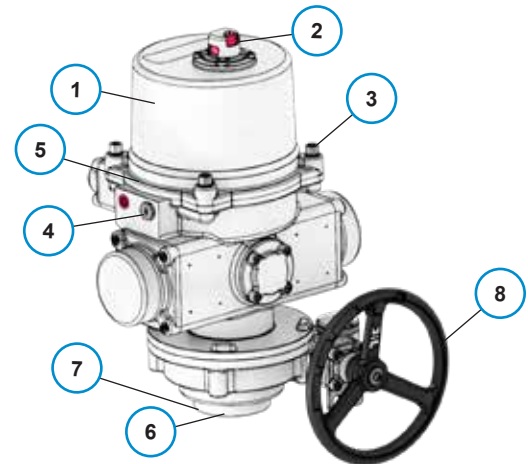

Wiring Diagrams

Typical wiring diagram shown.

Max-Air reserves the right to change specifications through a continuous-improvement program.

Contact Max-Air for product specific wiring diagrams prior to engineering or installation efforts.

