



Safety First!

Throughout the installation phases and operation of this equipment, safety procedures take precedence over all other activities. As a minimum:



1. Read and follow all instructions in this IOM.



2. Risk of electric shock! All wiring must be in accordance with applicable local codes, regulations and the NEC. Be aware that there may be hazardous voltages present which can shock, burn, or possibly cause permanent injury or even death.



3. Before handling electrical connections, disconnect power feeds. There may be multiple power feeds connected to this unit. Check carefully when handling the actuator's flying-lead cable and connections.



4. This is a mechanical gear train system with high torque outputs. Connected mechanical linkages can and will cause personal injury if the user encounters a pinch-point during movement.

Handling & Storage:

1. This device is an electrically powered mechanical transmission system. It is comprised of a brushless DC or synchronous AC motor, logic control PC boards, various discrete electronic components and electrical storage devices, all of which are susceptible to damage from high humidity environments. For this reason, this device must be protected from direct contact with water and/or high humidity storage environments.

2. Protect the device from physical damage while awaiting the completion of installation processes.

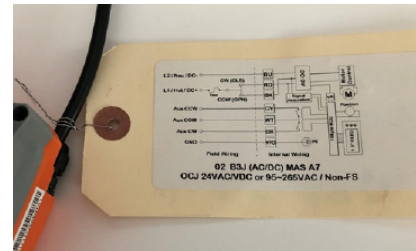

Fig. 1

Installation:

1. Confirm correct voltage and control before wiring and powering up this actuator.

2. This device has been permanently lubricated at time of assembly. Maintain proper lubrication level by ensuring the actuator is mounted with the top cover at or above horizontal. This device is NOT designed to mount with the top cover below horizontal.

3. The OLED display window should be protected from direct sunlight, to keep it from clouding as well as to make it easier to read during maintenance sessions.

4. Do NOT press the OLED panel function buttons when the unit is in direct contact with water.

5. Do NOT pull on the electrical cable or hang the product using the electrical cable as a hanging anchor.

6. Protect the termination-end of the cable from water ingress by using an appropriate wiring gland or seal.

7. When mounting this device to a valve or damper, ensure the mating between the valve stem (or coupling) is NOT deeper than the socket depth in the bottom of the actuator. Use the proper length and thread bolts for mounting. (See dims diagram).

8. Ensure the actuator is concentrically mounted to the valve stem. Non-concentricity causes premature actuator or valve-stem seal failure, or actuator stalling due to high-torque during travel.

9. Refer to the wiring diagram attached to the flying lead on the actuator (see Fig 1) for wiring connections. You can also scan the QR code above and navigate to the Max-Air website to obtain a full-size wiring diagram.

10. Do NOT parallel wire multiple on-off actuators to the same field control terminals.

11. Do NOT operate the actuator with any covers removed.

12. It is recommended to operate the actuator for at least ten minutes once per month, as a minimum.



Default Operating Modes: (refer to Fig 2a & 2b)

This manual is written for OLED Firmware version 13.9. Confirm the actuator firmware vision by pressing the K2 & K3 simultaneously and reading the OLED display (The firmware version flashes by fast, it may take a couple tries to read it).

1. This manual may not work properly if used on other than Ver 13.9 units.

2. When the unit is powered up and has no analog signal present, the display will indicate "IDLE" or "PNOWKSP SBRAKE" (See Fig 2a). With an active analog signal, the display will provide stored energy remaining if the unit is a super-cap model, and dynamic data on the actuator positioning (Fig 2b). Note that the actuator may not fully reach 0.0% or 100.0% depending on pre-programmed limits and how the actuator was mated to the valve.

3. After about 120 seconds of receiving no new commands, the display will return to "IDLE" or "PNOWKSP SBRAKE" (Fig 2a). Any change in command (or pressing the M key) will wake up the display to show current status.



Fig. 2a



Fig. 2b

Manual Operating Mode: (refer to Fig 3a, 3b)

The following procedure will allow the user to position the damper or valve using the push buttons on the OLED display.

4. To bypass the active incoming signal and operate the actuator manually in local mode, press the K3 key for five seconds at which time MANUAL PassWord: 00"0" will flash. (Fig 3a). Press the K2 or K3 keys until the display reads "111". Now press the M key to enter manual mode.



Fig. 3a

5. While in Manual mode, press the K2 key to drive CW (close), and press the K3 key to drive CCW (open). The display will show "MANUAL:" as well as the angular percentage of OPEN. (Fig 3b). Note that travel is allowable only to the extent of EOT (end of travel) settings established during the calibration (ref steps 8~12 below).



Fig. 3b

6. After approx 150 seconds with no key pressing, the unit reverts back to automatic mode and responds to the active incoming analog signal.

7. To immediately return to auto mode, press the M key.

Calibration: (refer to Fig 4a~4b)

This device has the ability to set travel stops using the OLED menu and therefore the cover does NOT need to be removed. Once the actuator is mounted to the valve or damper, the travel stops can be set using the following procedure: (Once started, this sequence must be completed in its entirety.... Follow this sequence and don't skip steps).



Fig. 4a

8. Press the M key and the K3 key together ("MK3" will be flashing) until the display reads "Factory Set PassWord: 00"0" (Fig 4a). Press K2 and K3 keys to set the password to "123", then press the M key to enter the calibration mode (Fig 4b).



Fig. 4b

9. Press the K3 key to drive the actuator to its intended full CCW EOT (End of Travel). The position indicator MUST be rotating CCW until it is more than 50% YELLOW, and the position indicator must show approx 2600 when at the full 90° CCW position, and near 3800 for the 180° (MAX) position. Now press the M key to select CCW_90°: #### and press K3 to SAVE the position. "SaveOK" will flash). Press the M key to continue.



Fig. 5a

10. Press the K2 key to drive the actuator to its intended full CW EOT (End of Travel). The position indicator MUST be rotating CW until it is more than 50% RED, and the position indicator must show <2000 when at the full 0° CCW position. At no time should the display show less than 50. Press K3 to SAVE the position. (Save OK will flash).

11. Press the M key to reach the exit screen, and press K3 to exit.

12. Repeat from step 8 if an error is made.

File Name: Max-Air_Max-Electric_IOM_MA-02-A-Adv-Mod.pdf



Setting Advanced Operating Parameters: (refer to Fig 5a~5i)

There are several settings that allow the actuator to respond more accurately to the control system. Care should be taken to only change parameters that need changing and the operator understands the impact of said changes. Parameters that are changed in the field may damage the actuator if done incorrectly. (Contact Max-Air Technology for assistance).

13. Set the actuator to Setup mode. (Fig 5a). Press the M key for five seconds at which time UserSET PassWord 00"0" will flash. Press the K2 or K3 keys until the display reads "333". Now press the M key to enter the parametric setting mode.

14. Level 1 screen: Language is English (default). The K3 key toggles the selection. Press M to go to next parameter.

15. Level 2 screen (Fig 5b): Control Mode: Channel: 4-20mA (fixed). The MA 02 Mod Series control mode cannot be changed. Press M 4 times to go to next parameter. (The next three menus are bypassed).

16. Level 6 screen (Fig 5c): Control Response: Dir (20mA = CCW default). Choice is Rev (20mA = CW). The K3 key toggles the selection. Press M to go to next parameter.

17. Level 7 screen (Fig 5d): Loss of Control Signal response: The MA 02 Series PDAction setting is fixed to OFF (CW) and cannot be changed. Press M 17 times to go to next parameter. (The next several menus are bypassed).

18. Level 24 screen: Sets CW (4mA) EOT position as a function of % of full scale. (0.0% is default) (Fig 5f). The K2/K3 keys toggle the selection. Caution: This setting overrides the CW EOT setting established in step Press M to go to next parameter.

20. Level 25 screen: Sets CCW (20mA) EOT position as a function of % of full scale. (100.0% is default) (Fig 5g). The K2/K3 keys toggle the selection. Press M 6 times to go to next parameter. (The next several menus are bypassed).

21. Level 31 screen (Super-cap equipped): Power Down Action: Determines the final position after a power failure: NOCK (no power-down check - Default). Choices are: ON (full CCW), Off (full CW), B33 (preset midpoint), KEEP (maintain last signal position). (Fig 5h). The K3 key toggles the selection. Press M twice to go to next parameter.

22. Level 33 screen: Exit Setting: Press K3 to exit to standard operating mode. Press M to go back to start of parameter settings (Fig 5i).

Fail-Safe Mode

MA 02 Models equipped with the EFS option (Super-capacitor fail-safe positioning) are fixed to fail CW (closed) upon loss of power.

Note that the program will revert back to normal operation when no buttons are pressed for a period of five minutes.



Fig. 5b



Fig. 5c



Fig. 5d



Fig. 5f



Fig. 5g



Fig. 5h

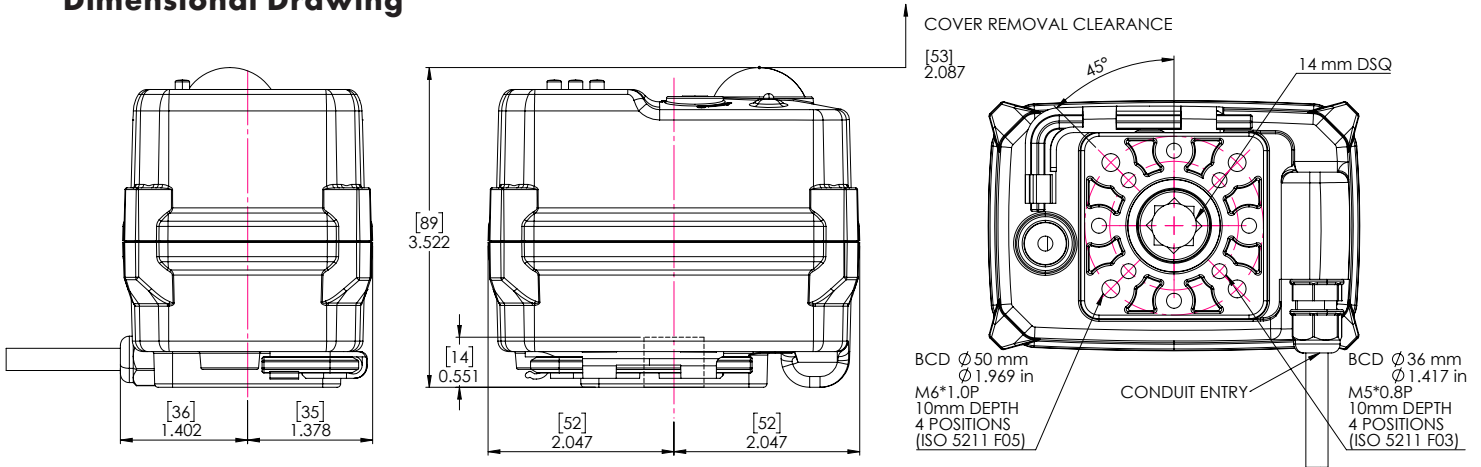

Fig. 5i

File Name: Max-Air_Max-Electric_IOM_MA-02-A-Adv-Mod.pdf



Dimensional Drawing



Specifications

		MAM02R-A24AD-ABSFS	MAM02S-A24AD-ABSNF
24V	Supply	Torque Output (in-lb / Nm)	177"lb / 20Nm
		Power Consumption (Max/Run/Hold)	36W / 9.6W / 0.6W
		Peak Current (@ Rated Voltage)	1.5A, 5ms @ 24VDC
		Fuse Rating	5A
		Speed (90°) DC-60Hz/50Hz, seconds	10s Mains; 15s EFS
		Duty Cycle (IEC60034)	S3-85% @ ≤85% rated torque
		Motor Power	36W
		Motor Protection, Temp / Class	155°C / Class F
		Fail-Safe (EFS)	SuperCap
		Fail Direction on loss of power	CW - Fixed
	Modulating Control - Max starts / hour	50	
	Product Weight (lbs / kg)	1.36lbs / 0.62 kg	

		MAM02R-A9265-ABSFS	MAM02S-A9265-ABSNF
95~ 265VAC	Supply	Torque Output (in-lb / Nm)	177"lb / 20Nm
		Power Consumption (Max/Run/Hold)	36W / 10W / 1.2W
		Peak Current (@ Rated Voltage)	0.16A, 5ms @ 220VAC
		Fuse Rating	5A
		Speed (90°) DC-60Hz/50Hz, seconds	10s Mains; 15s EFS
		Duty Cycle (IEC60034)	S3-85% @ ≤85% rated torque
		Motor Power	36W
		Motor Protection, Temp / Class	155°C / Class F
		Fail-Safe (EFS)	SuperCap
		Fail Direction on loss of power	CW - Fixed
	Modulating Control - Max starts / hour	50	
	Product Weight (lbs / kg)	1.36lbs / 0.62 kg	

ALL	Control	4-20mA Input/Feedback, Fixed
	Electrical Entry	M10 nickel-plated brass cable gland (x1)
	Auxiliary Switch - Type	None, Analog feedback is standard
	Auxiliary Switch - End of Travel	None
	End-of-Travel Adjustment	Programmable thru OLED Menu
	Manual Override	4mm hex key, stored in lower housing clip
	De-clutch mechanism	None required
	Environmental Rating	IP67 Indoor / Outdoor (requires sun/rain shield)
	Ambient Operating Range	5°F to +140°F / -15°C to +60°C
	Humidity Range	0-95% RH
Altitude Limit	9850 ft / 3000 m	

File Name: Max-Air_Max-Electric_IOM_MA-02-A-Adv-Mod.pdf