



Safety First!

Throughout the installation phases and operation of this equipment, safety procedures take precedence over all other activities. As a minimum:



1. Read and follow all instructions in this IOM.



2. Risk of electric shock! All wiring must be in accordance with applicable local codes, regulations and the NEC. Be aware that there may be hazardous voltages present which can shock, burn, or possibly cause permanent injury or even death.



3. Before handling electrical connections, disconnect power feeds. There may be multiple power feeds connected to this unit. Check carefully when handling the actuator's flying-lead cable and connections.



4. This is a mechanical gear train system with high torque outputs. Connected mechanical linkages can and will cause personal injury if the user encounters a pinch-point during movement.

Handling & Storage:

1. This device is an electrically powered mechanical transmission system. It is comprised of a brushless DC or synchronous AC motor, logic control PC boards, various discrete electronic components and electrical storage devices, all of which are susceptible to damage from high humidity environments. For this reason, this device must be protected from direct contact with water and/or high humidity storage environments.

2. Protect the device from physical damage while awaiting the completion of installation processes.

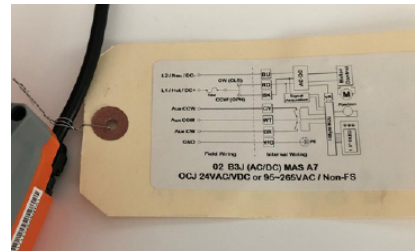

Fig. 1

Installation:

1. Confirm correct voltage and control before wiring and powering up this actuator.

2. This device has been permanently lubricated at time of assembly. Maintain proper lubrication level by ensuring the actuator is mounted with the top cover at or above horizontal. This device is NOT designed to mount with the top cover below horizontal.

3. Do NOT pull on the electrical cable or hang the product using the electrical cable as a hanging anchor.

4. Protect the termination-end of the cable from water ingress by using an appropriate wiring gland or seal.

5. When mounting this device to a valve or damper, ensure the mating between the valve stem (or coupling) is NOT deeper than the socket depth in the bottom of the actuator. Use the proper length and thread bolts for mounting. (See dims diagram).

6. Ensure the actuator is concentrically mounted to the valve stem. Non-concentricity causes premature actuator or valve-stem seal failure, or actuator stalling due to high-torque during travel.

7. Refer to the wiring diagram attached to the flying lead on the actuator (see example Fig 1) for wiring connections.

8. Do NOT parallel wire multiple on-off actuators to the same field control terminals.

9. Do NOT operate the actuator with any covers removed.

10. It is recommended to operate the actuator for at least ten minutes once per month, as a minimum.

**Default Operating Mode:**

This manual is written for Standard (basic) units without an OLED display.

1. This is an on/off actuator which must not be parallel wired with other on/off actuators.
2. Once the unit is powered up, it will respond to movement commands from the field controller (reference the wiring diagram on the flying lead).
3. This unit is NOT equipped with a fail-safe positioning system. This unit will stay in its current position should a power failure occur during operation.

Calibration: (refer to Figs 2 & 3)

Travel stops are manually set in this device.

1. Remove power from the actuator, and remove the top cover.
2. Position the actuator to its fully CLOSED (CW) position. Use a 2.5mm hex key to free up the UPPER cam set screw. If the CW travel is too far CW, rotate the cam slightly to the LEFT, and vice versa if the CW travel is not far enough. Tighten the cam setscrew. (Do not overtighten).
3. Power up the actuator and drive it CCW a few degrees, then drive CW again to check the cam setting. Repeat if necessary.
4. Position the actuator to its fully OPEN (CCW) position. Use a 2.5mm hex key to free up the LOWER cam set screw. If the CCW travel is too far CCW, rotate the cam slightly to the RIGHT, and vice versa if the CCW travel is not far enough. Tighten the cam setscrew. (Do not overtighten).
3. Power up the actuator and drive it CW a few degrees, then drive CCW again to check the cam setting. Repeat if necessary.

Fail-Safe Mode

This model is not equipped with a supercap backup system.

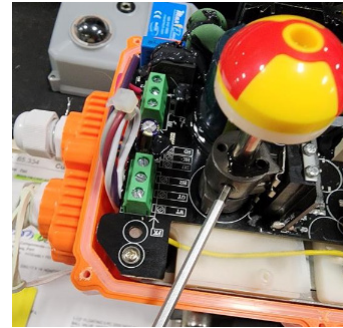

Fig. 2 - CW Travel Cam Setting

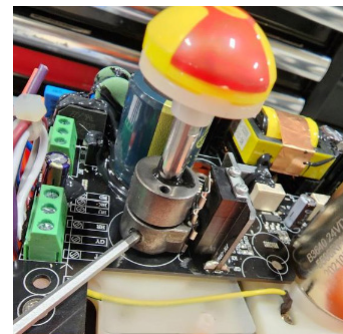
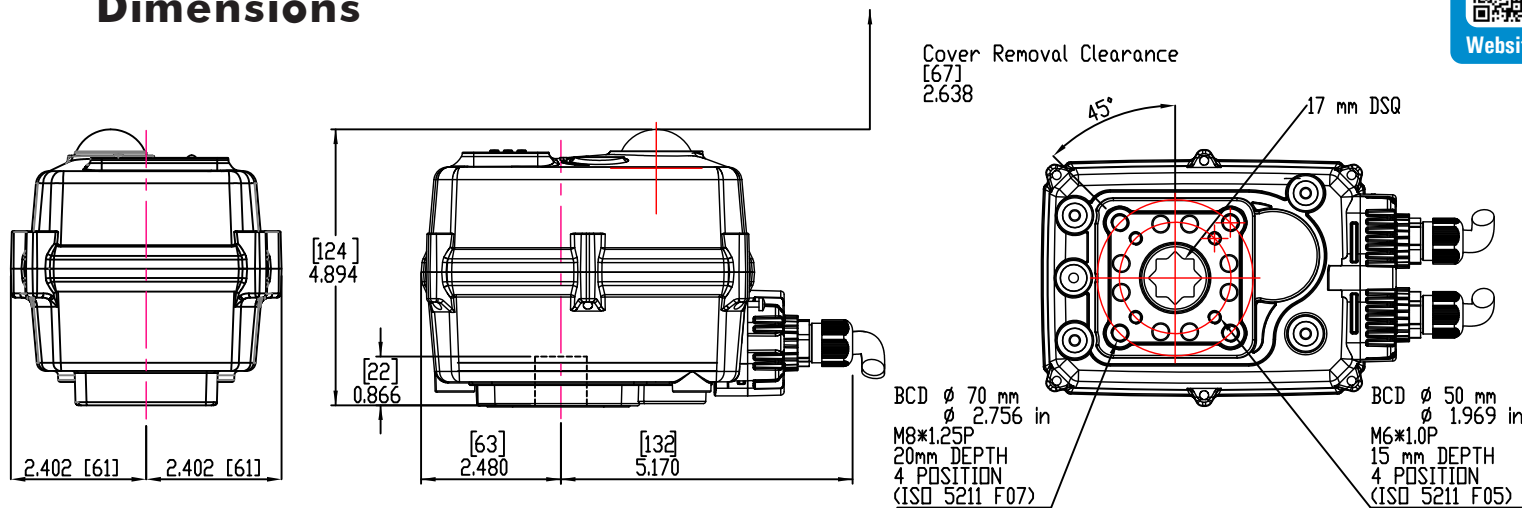

Fig. 3 - CCW Travel Cam Setting



Website

Dimensions



Specifications

		MAR08R-P24AD-S2SFS	MAR08S / MAS08S-P24AD-S2/3SNF
24V	Supply	Torque Output (in-lb / Nm)	708"lb / 80Nm
		Power Consumption (Max/Run/Hold)	60W / 9.6W / 1.6W
		Peak Current (@ Rated Voltage)	2.5A, 5ms @ 24VDC
		Fuse Rating	7A
		Speed (90° DC-60Hz/50Hz, seconds)	10s
		Duty Cycle (IEC60034)	S3-85% @ ≤85% rated torque
		Motor Power	60W
		Motor Protection, Temp / Class	155°C / Class F
		Fail-Safe (EFS)	SuperCap
		Fail Direction on loss of power	CW - Fixed
	2 Position Control - Max starts / hour	50	
	Product Weight (lbs / kg)	6.60lbs / 3.00 kg	

		MAR08R-P9265-S2SFS	MAR08S / MAS08S-P9265-S2/3SNF
95~265VAC	Supply	Torque Output (in-lb / Nm)	708"lb / 80Nm
		Power Consumption (Max/Run/Hold)	60W / 9.6W / 2.3W
		Peak Current (@ Rated Voltage)	0.27A, 5ms @ 220VAC
		Fuse Rating	5A
		Speed (90° DC-60Hz/50Hz, seconds)	10s
		Duty Cycle (IEC60034)	S3-85% @ ≤85% rated torque
		Motor Power	60W
		Motor Protection, Temp / Class	155°C / Class F
		Fail-Safe (EFS)	SuperCap
		Fail Direction on loss of power	CW - Fixed
	2 Position Control - Max starts / hour	50	
	Product Weight (lbs / kg)	6.60lbs / 3.00 kg	

ALL	Control	Open/Close, Open/Close/Jog
	Electrical Entry	M12 polyamide cable gland (x2) & removable terminal block access plate
	Auxiliary Switch - Type	(2) mechanical, Form A
	Auxiliary Switch - End of Travel	(2) Form A Volt-Free, Rated 0.1A @ 250vac, 0.5A @ 30VDC
	End-of-Travel Adjustment	Manual positioning, under cover
	Manual Override	5mm hex key, stored in lower housing clip
	De-clutch mechanism	None required
	Environmental Rating	IP67 Indoor / Outdoor (requires sun/rain shield)
	Ambient Operating Range	5°F to +140°F / -15°C to +60°C
	Humidity Range	0-95% RH
Altitude Limit	9850 ft / 3000 m	

File Name: Max-Electric_IOM_MA-08-S-Std-OC.J.pdf