



Safety First!

Throughout the installation phases and operation of this equipment, safety procedures take precedence over all other activities. As a minimum:



1. Read and follow all instructions in this IOM.



2. Risk of electric shock! All wiring must be in accordance with applicable local codes, regulations and the NEC. Be aware that there may be hazardous voltages present which can shock, burn, or possibly cause permanent injury or even death.



3. Before handling electrical connections, disconnect power feeds. There may be multiple power feeds connected to this unit. Check all terminal connections carefully when servicing the actuator.



4. This is a mechanical gear train system with high torque outputs. Connected mechanical linkages can and will cause personal injury if the user encounters a pinch-point during movement.

Handling & Storage:

1. This device is an electrically powered mechanical transmission system. It is comprised of a DC motor, an asynchronous AC motor, or a polyphase AC motor, logic control PC boards, various discrete electronic components and electrical storage devices, all of which are susceptible to damage from high humidity. For this reason, this device must be protected from direct contact with water and/or high humidity storage environments.

2. Protect the device from physical damage while awaiting the completion of installation processes.

3. If this product is installed in water valve systems and remains unpowered during construction phases, condensate will accumulate and possibly damage the product. This product MUST be powered up at all times once it is installed in active piping systems.

Installation:

1. Confirm correct voltage and control before wiring and powering up this actuator.

2. This device has been permanently lubricated at time of assembly. Maintain proper lubrication level by ensuring the actuator is mounted with the top cover at or above horizontal. This device is NOT designed to mount with the top cover below horizontal.

3. Use approved conduit entry components to protect the interior of the unit from ingress of foreign materials (including water). Utilize drip loops to prevent conduit condensate from accumulating and entering the actuator through the EMT port(s).

4. Refer to the dimensional diagram (pg 4) for proper clearance on all sides as well as the top cover clearance requirements. Determine proper access space for the manual override system.

5. When mounting this device to a valve or damper, ensure the mating between the valve stem (or coupling) is NOT deeper than the socket depth in the bottom of the actuator. Use the proper length and thread bolts for mounting. (See dimensional diagram pg 4).

6. Ensure the actuator is concentrically mounted to the valve stem. Non-concentricity causes premature actuator or valve-stem seal failure, or actuator stalling due to high-torque during travel.

7. Use properly sized power supplies and wire gauge over distance to prevent actuator failure from stalling and overheating.

8. Refer to the wiring diagram sheet (folded, inserted under the actuator cover) for wiring connections. You can also scan the QR code above and navigate to the Max-Air website to obtain a full-size wiring diagram.

9. Do NOT parallel wire multiple on-off actuators to the same field control terminals. This WILL cause unexpected movement of the actuator(s), overheating and premature failure.

10. After installation and testing, do NOT operate the actuator with any covers removed.

11. It is recommended to operate the actuator for at least ten minutes once per month, as a minimum.

12. The internal heater is to be used in ALL applications.

13. There are NO mechanical stops on this actuator. When using the manual override on the bottom of the actuator, pay attention to the 3D position indicator (Fig 1) on the top side to prevent overtravel outside the intended travel range.



This actuator has been factory calibrated to operate between 0° and 90°. Most quarter-turn products will not require recalibration of these settings.

Default Operating Mode:

This actuator leaves the factory with the following default settings:
Input signal is 4-20mA, response is direct acting (20mA = full CCW - OPEN), feedback is 4-20mA, Unit is set for 90° travel, and sensitivity is set at "3" (0.5% full scale).

This manual is written for proportional control actuators with DC or single phase AC drive motors. (This may NOT be the same as the power supply feeding the actuator).

This actuator must be calibrated prior to putting into service. If this is a stand-alone actuator, follow all the steps given here after mounting the actuator to the driven device (valve, damper or other). If this actuator has been factory mounted to the driven device, more than likely it has already gone thru calibration and nothing further needs to be done.

1. The bare actuator normally ships in the full CW (Closed) position. This can be verified by observing the top-mounted 3D position indicator before the top cover is removed. When in the full CW position, the color showing is RED and "CLOSE" is visible thru the window. (Fig 1)

2. Do NOT apply power at this time.

3. Set the CW end of travel cam.

a. Use the bottom-mounted 8mm hex manual override shaft to drive the actuator out to about 15~20 degrees open, then back to the desired CLOSED (CW) position. If you have driven the device too far, you must drive back out to 15~20 degrees before again approaching the correct CW stop. You cannot set the stop when driving in a CCW direction due to cam dwell angle.

b. Using a 2.5mm hex key on CAM #2 (Fig 2), loosen the cam set screw and rotate the cam CCW by pushing the hex key to the RIGHT a few degrees. Lightly snug up on the set screw until resistance is felt against the cam shaft. Pull the hex key to the LEFT SLOWLY until you hear a "click" from the associated (#2) cam switch and snug up on the cam setscrew. Do not move the actuator. No need to overtighten the cam setscrew.

4. Set the CW auxiliary switch.

a. Using the 2.5mm hex key on CAM #4 (Fig 3) loosen the cam set screw and rotate the cam CCW by pushing the hex key to the RIGHT a few degrees. Lightly snug up on the set screw until resistance is felt against the cam shaft. Pull the hex key to the LEFT SLOWLY until you hear a "click" from the associated (#4) cam switch and continue a few more degrees in the same direction. (This assures the AUX switch trips before the actuator reaches its end of travel. Snug up on the cam setscrew.

5. Set the CCW end of travel cam.

a. Use the 8mm hex manual override shaft to drive the actuator out to about 75~80 degrees open, and then slowly to the desired FULL OPEN (CCW) position. If you have driven the device too far, you must drive back out to 75~80 degrees before again approaching the correct CCW stop. You cannot set the stop when driving in a CW direction due to cam dwell angle.

b. Using a 2.5mm hex key on CAM #1 (Fig 4), loosen the cam set screw and rotate the cam CW by pushing the hex key to the LEFT a few degrees. Lightly snug up on the set screw until resistance is felt against the cam shaft. Pull the hex key to the RIGHT SLOWLY until you hear a "click" from the associated (#1) cam switch and snug up on the cam setscrew. Do not move the actuator. No need to overtighten the cam setscrew.

6. Set the CCW auxiliary switch.

a. Using the 2.5mm hex key on CAM #3 (Fig 5) loosen the cam set screw and rotate the cam CCW by pushing the hex key to the LEFT a few degrees. Lightly snug up on the set screw until resistance is felt against the cam shaft. Pull the hex key to the RIGHT SLOWLY until you hear a "click" from the associated (#3) cam switch and continue a few more degrees in the same direction. (This assures the AUX switch trips before the actuator reaches its end of travel. Snug up on the cam setscrew.

If this actuator has left the Max-Air factory as a valve assembly, the analog response has already been calibrated and should require no adjustments. Should another calibration be needed, proceed cautiously with the following steps:

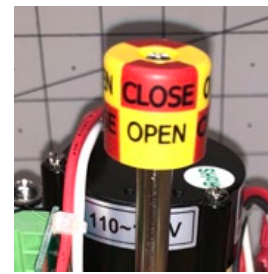

Fig 1 - 3D position indicator identifies the rotation angle of the actuator.

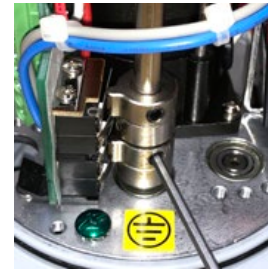

Fig 2 - CW EOT Cam adjustment



Fig 3 - CW AUX Cam adjustment



Fig 4 - CCW EOT Cam adjustment



Fig 5 - CCW AUX Cam adjustment

**7. Set the signal processing for the actuator.**

Use the table below to set the eight (8) DIP switches to establish signal type, response and fault modes of operation. (yellow cells are default settings)

DIP	S1	S2	S3	S4	S5	S6		S7	S8
MODE	INPUT		FEEDBACK			RESPONSE	LOSS OF SIGNAL		
4-20mA	ON	OFF	OFF	ON	OFF	OFF = DIR	CW	OFF	ON
							CCW	ON	OFF
							LAST	ON	ON
2-10VDC	OFF	ON	ON	OFF	ON	ON = REV	CW	ON	OFF
							CCW	OFF	ON
							LAST	ON	ON

8. Set the signal response. (ref Fig 6) Remove power. Generate a 20mA control signal from your field controller. Also attach a 4-20mA reader between terminals 11(-) & 12(+). Manually position the actuator to about 50% open, and then re-apply power. The actuator will travel in a CCW direction until it reaches its full CCW (OPEN) end of travel position (set by cam#1 in step 5 above). Turn VR1 (see Fig) 10~12 turns CCW or until the GRN LED turns off. Then slowly rotate VR1 CW until the GRN LED just starts to turn back on. This sets the 20mA response.

9. Without moving the actuator, turn VR51 (CW to decrease feedback signal or CCW to increase the feedback signal) until your loop reader shows 20mA. If the GRN LED should turn off while adjusting VR51, turn VR1 CW until the GRN LED turns back on.

10. Generate a 4mA control signal from your field controller. The actuator will travel in a CW direction until it reaches its full CW (CLOSED) end of travel position (set by cam#2 in step 3 above). Turn VR2 10~12 turns CCW or until the RED LED turns off. Then slowly rotate VR2 CW until the RED LED just starts to turn back on. This sets the 4mA response.

11. Without moving the actuator, turn VR52 (CW to decrease feedback signal or CCW to increase the feedback signal) until your loop reader shows 4mA. If the RED LED should turn off while adjusting VR52, turn VR2 CW until the RED LED turns back on.

12. After setting the analog response, check the operation of the actuator in response to your input signals to make sure operation is as intended. After verification that all settings are correct, generate a 4mA input signal to drive the actuator to its full CW position, and wait for it to stop.

13. Cycle power any time a DIP setting changes or trimmers are adjusted to get the new settings into the microprocessor logic.

This completes the calibration of the actuator.

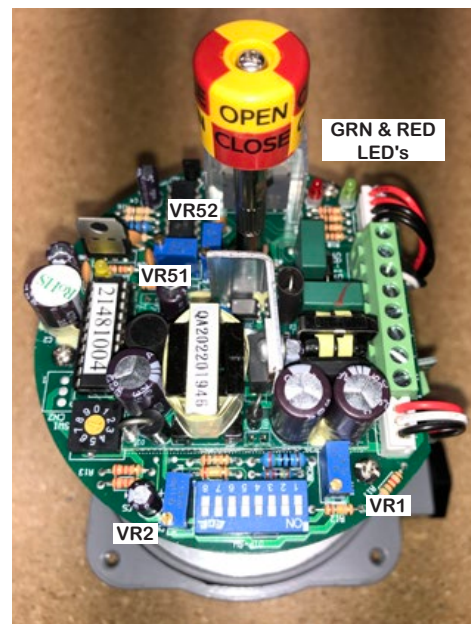
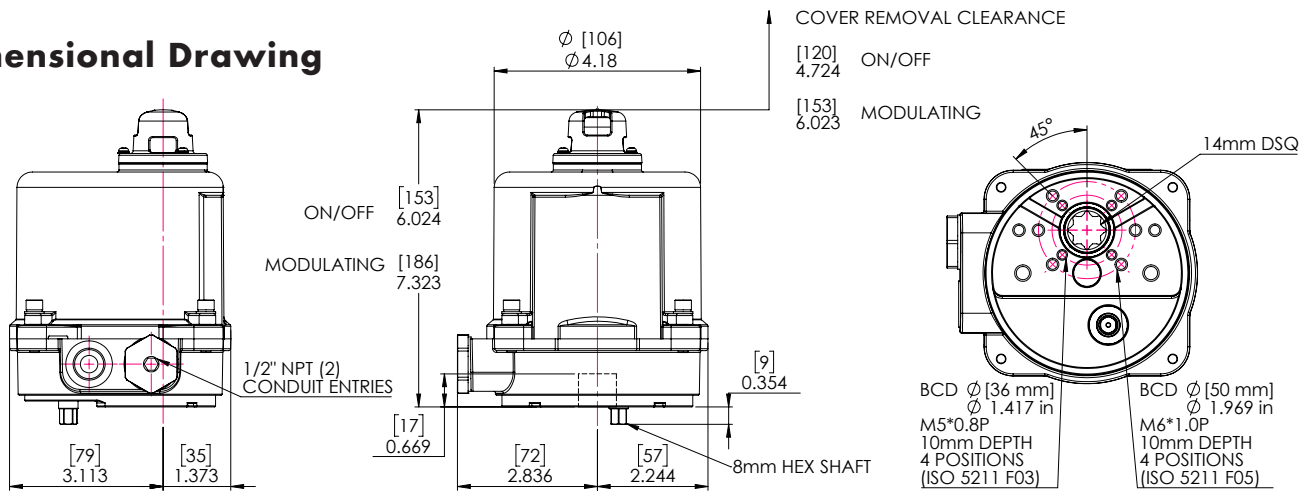

Fig 6 - Calibrating the four trimmers VR1, VR2, VR51, VR52 for proper analog response and feedback.



Dimensional Drawing



Specifications

		ME A003
Supply	Torque Output (in-lb / Nm)	310 in-lb / 35Nm
12V	Starting Current - DC Amps	3.0A
	Running Current - DC Amps	2.1A
	Speed (90°) @DC, seconds @ rated load	22 sec
	Motor, Voltage, Type, Class	12VDC 2-Pole Brush, Class F
	Motor Power	10W
	Duty Cycle	100% (EN 60034) / Class A/B/C (ISO 22153)
24V	Starting Current - DC Amps	2.0A
	Running Current - DC Amps	1.4A
	Speed (90°) @DC, seconds @ rated load	18 sec
	Motor, Voltage, Type, Class	24VDC 2-Pole Brush, Class F
	Motor Power	10W
	Duty Cycle	100% (EN 60034) / Class A/B/C (ISO 22153)
120V	Starting Current - AC Amps	2.0A
	Running Current - AC Amps	0.7A
	Speed (90°) @60Hz, seconds @ rated load	12 sec
	Motor, Voltage, Type, Class	120VAC Split-Phase Cap Run TENV Class F
	Motor Power	10W
	Duty Cycle	100% (EN 60034) / Class A/B/C (ISO 22153)
230V	Starting Current - AC Amps	3.0A
	Running Current - AC Amps	0.4A
	Speed (90°) @60Hz, seconds @ rated load	15 sec
	Motor, Voltage, Type, Class	230VAC Split-Phase Cap Run TENV Class F
	Motor Power	10W
	Duty Cycle	100% (EN 60034) / Class A/B/C (ISO 22153)
ALL	Environmental Rating	NEMA 4/4X & IP67
	Electrical Entry	1/2" EMT x 2
	Control	Open/Close, Modulating, 2 Position, 3 Position
	Auxiliary Switch - End of Travel	(2) Form C Volt-Free, Shared Common, Rated 3A @ 250vac, 0.5A @ 30VDC
	Ambient Operating Range	-22°F~+149°F (-30°C~+65°C)
	Humidity Range	0-95% RH
	Altitude Limit	9850 ft / 3000 m
	Weight (kg / lbs)	2 kg / 4.4 lbs

* All Amperage and speed specifications based on Open/Close Standard Duty motors @ 40°C ambient.

File Name: Max-Air_IOM_ME_A003_LVHV_Mod_converted.pdf

