



### Safety First!

Throughout the installation phases and operation of this equipment, safety procedures take precedence over all other activities. As a minimum:



1. Read and follow all instructions in this IOM.



2. Risk of electric shock! All wiring must be in accordance with applicable local codes, regulations and the NEC. Be aware that there may be hazardous voltages present which can shock, burn, or possibly cause permanent injury or even death.



3. Before handling electrical connections, disconnect power feeds. There may be multiple power feeds connected to this unit. Check all terminal connections carefully when servicing the actuator.



4. This is a mechanical gear train system with high torque outputs. Connected mechanical linkages can and will cause personal injury if the user encounters a pinch-point during movement.

### Handling & Storage:

1. This device is an electrically powered mechanical transmission system. It is comprised of a DC motor, an asynchronous AC motor, or a polyphase AC motor, logic control PC boards, various discrete electronic components and electrical storage devices, all of which are susceptible to damage from high humidity. For this reason, this device must be protected from direct contact with water and/or high humidity storage environments.

2. Protect the device from physical damage while awaiting the completion of installation processes.

3. If this product is installed in water valve systems and remains unpowered during construction phases, condensate will accumulate and possibly damage the product. This product MUST be powered up at all times once it is installed in active piping systems.

### Installation:

1. Confirm correct voltage and control before wiring and powering up this actuator.

2. This device has been permanently lubricated at time of assembly. Maintain proper lubrication level by ensuring the actuator is mounted with the top cover at or above horizontal. This device is NOT designed to mount with the top cover below horizontal.

3. Use approved conduit entry components to protect the interior of the unit from ingress of foreign materials (including water). Utilize drip loops to prevent conduit condensate from accumulating and entering the actuator through the EMT port(s).

4. Refer to the dimensional diagram (pg 4) for proper clearance on all sides as well as the top cover clearance requirements. Determine proper access space for the manual override system.

5. When mounting this device to a valve or damper, ensure the mating between the valve stem (or coupling) is NOT deeper than the socket depth in the bottom of the actuator. Use the proper length and thread bolts for mounting. (See dimensional diagram pg 4).

6. Ensure the actuator is concentrically mounted to the valve stem. Non-concentricity causes premature actuator or valve-stem seal failure, or actuator stalling due to high-torque during travel.

7. Use properly sized power supplies and wire gauge over distance to prevent actuator failure from stalling and overheating.

8. Refer to the wiring diagram sheet (folded, inserted under the actuator cover) for wiring connections. You can also scan the QR code above and navigate to the Max-Air website to obtain a full-size wiring diagram.

9. Do NOT parallel wire multiple on-off actuators to the same field control terminals. This WILL cause unexpected movement of the actuator(s), overheating and premature failure.

10. After installation and testing, do NOT operate the actuator with any covers removed.

11. It is recommended to operate the actuator for at least ten minutes once per month, as a minimum.

12. The internal heater is to be used in ALL applications.

13. Mechanical travel stops are factory calibrated for 90 degree operation. These stops are NOT designed to adjust mechanical rotation by more than +/- 3 degrees.

14. Mechanical stops CANNOT be used to limit travel electrically. Stalling this unit will damage the drive motor and control PCB's.



**The purpose of the mechanical stops are for limiting the manual override only!! Serious damage to the actuator will result if the motor is allowed to drive the gear train into the mechanical stops!**

**This actuator has been factory calibrated to operate between 0° and 90°. Most quarter-turn products will not require recalibration of these settings.**

#### Default Operating Mode:

This actuator leaves the factory with the following default settings:  
Unit is set for 90° travel, with terminal 3 as the drive CCW command, and terminal 4 as the drive CW command.

This manual is written for OCJ (Open/Close/Jog) control actuators with DC or single phase AC drive motors. (This may NOT be the same as the power supply feeding the actuator).

**This actuator must be calibrated prior to putting into service.** If this is a stand-alone actuator, follow all the steps given here after mounting the actuator to the driven device (valve, damper or other). If this actuator has been factory mounted to the driven device, more than likely it has already gone thru calibration and nothing further needs to be done.

1. The bare actuator normally ships in the full CW (Closed) position. This can be verified by observing the location of the punched dimple in the main output drive on the bottom of the actuator. The dimple should be pointing towards the "0" in the lower housing casting. Use the handwheel to reposition the output gear if the position is incorrect. (Fig 1)

#### 2. Do NOT apply power at this time.

3. Use a 19mm box wrench and a 6mm hex key to back out BOTH mechanical stops. (Fig 2 & 3). Once the lock nut is loose, back out the stop screws by 3~4 full turns. Leave everything loose.

#### 4. Set the CW end of travel cam.

a. Rotate the handwheel (CCW) to drive the actuator out to about 15~20 degrees open, then back to the desired CLOSED (CW) position. If you have driven the device too far, you must drive back out to 10~15 degrees before again approaching the correct CW stop. You cannot set the stop when driving in a CCW direction due to cam dwell angle.

b. Using a 2.5mm hex key on CAM #2 (Fig 4), loosen the cam set screw and rotate the cam CCW by pushing the hex key to the RIGHT a few degrees. Lightly snug up on the set screw until resistance is felt against the cam shaft. Pull the hex key to the LEFT SLOWLY until you hear a "click" from the associated (#2) cam switch and snug up on the cam setscrew. Do not move the actuator. No need to overtighten the cam setscrew.

#### 5. Set the CW auxiliary switch.

a. Using the 2.5mm hex key on CAM #4 (Fig 5) loosen the cam set screw and rotate the cam CCW by pushing the hex key to the RIGHT a few degrees. Lightly snug up on the set screw until resistance is felt against the cam shaft. Pull the hex key to the LEFT SLOWLY until you hear a "click" from the associated (#4) cam switch and continue a few more degrees in the same direction. (This assures the AUX switch trips before the actuator reaches its end of travel. Snug up on the cam setscrew.

#### 6. Set the CCW end of travel cam.

a. Rotate the handwheel (CCW) to drive the actuator out to full OPEN (CCW) to check for any obstructions in operation. Rotate the handwheel back to about 75~80 degrees open, and then back to the desired OPEN (CCW) position. If you have driven the device too far, you must drive back out to 75~80 degrees before again approaching the correct CCW stop. You cannot set the stop when driving in a CW direction due to cam dwell angle.

b. Using a 2.5mm hex key on CAM #1 (Fig 6), loosen the cam set screw and rotate the cam CW by pushing the hex key to the LEFT a few degrees. Lightly snug up on the set screw until resistance is felt against the cam



Fig 1 - Bottom view of actuator showing the "0" mark (Closed [CW] position), the "1" mark (Open [CCW] position), and the dimple reference. The actuator is shipped from the factory in its fully CLOSED position.



Fig 2 - Right side (CW) mechanical stop



Fig 3 - Left side (CCW) mechanical stop



Fig 4 - CW EOT Cam adjustment



Fig 5 - CW AUX Cam adjustment



shaft. Pull the hex key to the RIGHT SLOWLY until you hear a "click" from the associated (#1) cam switch and snug up on the cam setscrew. Do not move the actuator. No need to overtighten the cam setscrew.

#### 5. Set the CCW auxiliary switch.

a. Using the 2.5mm hex key on CAM #3 (Fig 7) loosen the cam set screw and rotate the cam CCW by pushing the hex key to the LEFT a few degrees. Lightly snug up on the set screw until resistance is felt against the cam shaft. Pull the hex key to the RIGHT SLOWLY until you hear a "click" from the associated (#3) cam switch and continue a few more degrees in the same direction. (This assures the AUX switch trips before the actuator reaches its end of travel. Snug up on the cam setscrew.

6. After setting the end-of-travel cams and switches, check the operation of the actuator in response to your input signals to make sure operation is as intended. After verification that all settings are correct, generate a drive CW command to drive the actuator to its full CW position, and wait for it to stop.

**7. Set the CW mechanical stop.** (Fig 8) Use the 6mm hex key on the RIGHT side stop screw and turn it clockwise until it bottoms out against the internal stop boss on the final output drive. Turn the hex key ONE turn CCW, then use the 19mm box wrench to lock the stop screw in position. Do not tighten the stop screw so hard as to crush the sealing washer.

8. Generate a drive CCW command to drive the actuator to its full CCW position, and wait for it to stop.

**9. Set the CCW mechanical stop.** (Fig 9) Use the 6mm hex key on the LEFT side stop screw and turn it clockwise until it bottoms out against the internal stop boss on the final output drive. Turn the hex key ONE turn CCW, then use the 19mm box wrench to lock the stop screw in position. Do not tighten the stop screw so hard as to crush the sealing washer.

When the actuator reaches its end of travel electrically, you should be able to rotate the handwheel at least 1/2 or more turns before you reach the mechanical stop. This is true for both ends of travel. If the handwheel is "locked", the mechanical stops have been set incorrectly and must be reset. Any time the EOT cams need to be moved, the mechanical stops MUST be reset.

This completes the calibration of the actuator.



Fig 6 - CCW EOT Cam adjustment



Fig 7 - CCW AUX Cam adjustment



Fig 8 - Right side (CW) mechanical stop



Fig 9 - Left side (CCW) mechanical stop



### Dimensional Drawing

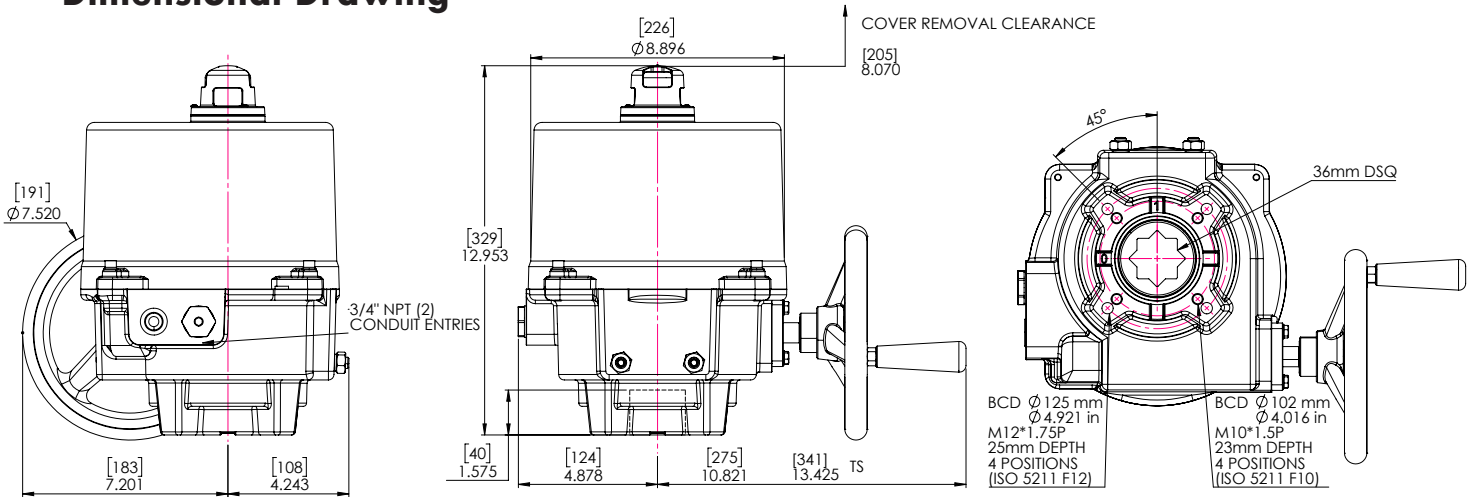

### Specifications

		ME G035	ME G044
Supply	Torque Output (in-lb / Nm)	3540 in-lb / 400Nm	4430 in-lb / 500Nm
12V	Starting Current - DC Amps	22.0A	27.0A
	Running Current - DC Amps	14.0A	14.9A
	Speed (90°) @DC, seconds @ rated load	21 sec	29 sec
	Motor, Voltage, Type, Class	12VDC 2-Pole Brush, Class F	12VDC 2-Pole Brush, Class F
	Motor Power	80W	80W
	Duty Cycle	100% (EN 60034) / Class A/B/C (ISO 22153)	
24V	Starting Current - DC Amps	20.0A	20.0A
	Running Current - DC Amps	7.7A	7.4A
	Speed (90°) @DC, seconds @ rated load	21 sec	28 sec
	Motor, Voltage, Type, Class	24VDC 2-Pole Brush, Class F	24VDC 2-Pole Brush, Class F
	Motor Power	80W	80W
	Duty Cycle	100% (EN 60034) / Class A/B/C (ISO 22153)	
120V	Starting Current - AC Amps	7.0A	7.0A
	Running Current - AC Amps	2.1A	2.0A
	Speed (90°) @60Hz, seconds @ rated load	19 sec	26 sec
	Motor, Voltage, Type, Class	120VAC Split-Phase Cap Run TENV Class F	120VAC Split-Phase Cap Run TENV Class F
	Motor Power	80W	80W
	Duty Cycle	100% (EN 60034) / Class A/B/C (ISO 22153)	
230V	Starting Current - AC Amps	4.0A	4.0A
	Running Current - AC Amps	1.1A	1.0A
	Speed (90°) @60Hz, seconds @ rated load	20 sec	26 sec
	Motor, Voltage, Type, Class	230VAC Split-Phase Cap Run TENV Class F	120VAC Split-Phase Cap Run TENV Class F
	Motor Power	80W	80W
	Duty Cycle	100% (EN 60034) / Class A/B/C (ISO 22153)	
ALL	Environmental Rating	NEMA 4/4X & IP67	
	Electrical Entry	3/4" EMT x 2	
	Control	Open/Close, Modulating, 2 Position, 3 Position	
	Auxiliary Switch - End of Travel	(2) Form C Volt-Free, Rated 10A @ 250vac, 5A @ 30VDC	
	Ambient Operating Range	-22°F~+149°F (-30°C~+65°C)	
	Humidity Range	0-95% RH	
	Altitude Limit	9850 ft / 3000 m	
	Weight (kg / lbs)	20 kg / 44.0 lbs	

\* All Amperage and speed specifications based on Open/Close Standard Duty motors @ 40°C ambient.

\*\* Refer to 3 phase data sheets for 3 phase power.

File Name: Max-Air\_IOM\_ME\_G035~044\_LVHV\_OCI\_converted.pdf

