

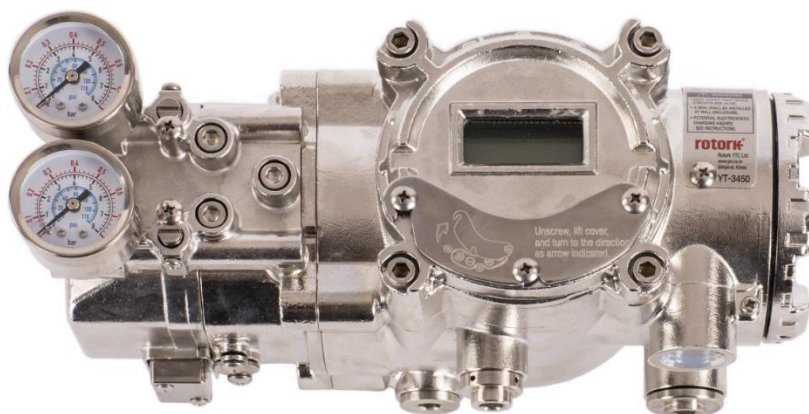

YT-3400



YT-3450

Terminal appearance

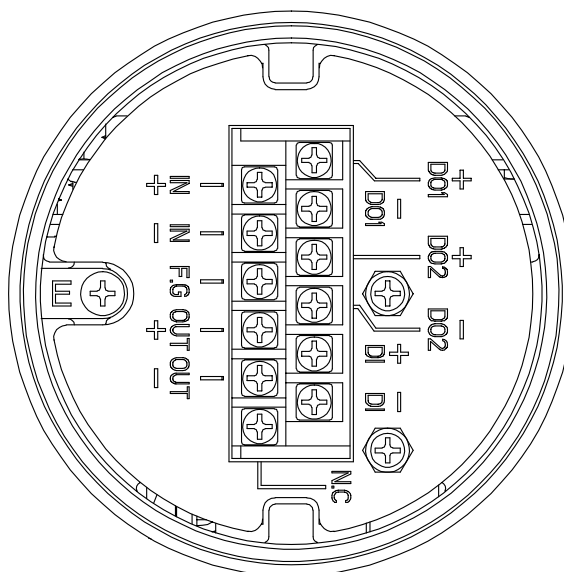

## Contents

<b>1</b>	<b>Introduction</b>	<b>6</b>
1.1	General Information for the users	6
1.2	Manufacturer Warranty	6
1.3	Explosion Proof Warning & Specific Conditions of Use	7
<b>2</b>	<b>Product Description</b>	<b>9</b>
2.1	General	9
2.2	Main Features and Functions	9
2.3	Label Description	10
2.4	Product Code	15
2.5	Product Specification	16
2.6	Specification of Digital Input, Digital Output	17
2.7	Certifications	18
2.8	Parts and Assembly	20
2.9	Product Dimension	21
2.9.1	YT-3400	21
2.9.2	YT-3450	22
<b>3</b>	<b>Installation</b>	<b>23</b>
3.1	Safety	23
3.2	Tools for installation	24
3.3	Linear positioner Installation	24
3.3.1	Safety	24
3.3.2	Positioner Installation Steps	25
3.4	Rotary positioner Installation	28
3.4.1	Components	28
3.4.2	Rotary Bracket Information	29
3.4.3	Rotary positioner Installation Steps	30
<b>4</b>	<b>Connection - Air</b>	<b>32</b>
4.1	Safety	32
4.2	Supply Pressure Condition	32
4.3	Piping Condition	32
4.4	Connection – Piping with actuator	33
4.4.1	Single acting actuator	33
4.4.2	Double acting actuator	33
<b>5</b>	<b>Connection – Power</b>	<b>34</b>
5.1	Safety	34
5.2	Terminal overview	35
5.2.1	Ground	38
<b>6</b>	<b>Adjustments</b>	<b>39</b>
6.1	A/M switch adjustment	39

---

6.2	Variable Orifice Adjustment .....	39
<b>7</b>	<b>Maintenance .....</b>	<b>40</b>
7.1	Supply air .....	40
7.2	Seals .....	40
<b>8</b>	<b>Auto Calibration and PCB Operation.....</b>	<b>41</b>
8.1	Warning.....	41
8.2	LCD display and buttons.....	41
8.2.1	LCD display and symbols .....	41
8.2.2	Button and function .....	42
8.3	Menu levels.....	43
8.4	Run Mode (RUN) .....	44
8.5	Configuration and Operation.....	45
8.6	Calibration (CALib) .....	50
8.6.1	Acting Type (SINGLE / dDOUBLE) .....	50
8.6.2	Auto Calibration 1 (AUTO 1).....	51
8.6.3	Auto Calibration 2 (AUTO 2).....	51
8.6.4	Travel Zero (TVL ZERO) and Travel end (TVL ENd) .....	52
8.7	Manual Operation (MAN OPER).....	53
8.7.1	Manual Operation by Set position (MAN SP) .....	53
8.7.2	Manual Operation by Manipulator Value (MAN MV) .....	54
8.8	Control Parameters (CTL PARM) .....	55
8.8.1	Dead Band (dEAdbANd).....	55
8.8.2	Forward P parameter (KP UP) and reverse P parameter (KP dN).....	56
8.8.3	Forward Integral time parameter (TI UP) and reverse Integral time parameter (TI dN) .....	56
8.8.4	Forward D parameter (Kd UP) and reverse D parameter (Kd dN) .....	57
8.8.5	GAP Parameter (GAP) .....	57
8.8.6	GAP P parameter (GP).....	58
8.8.7	GAP I parameter (GI).....	58
8.8.8	GAP D parameter (Gd) .....	58
8.8.9	Auto Dead band Mode (AUTO db) .....	59
8.8.10	Performance Mode (PER) .....	59
8.9	Input Configuration (IN CFG).....	60
8.9.1	Signal Direction (SIG NORM / REVS) .....	60
8.9.2	Split Range Mode (SPLIT).....	61
8.9.3	Custom Split Range Zero (CST ZERO).....	61
8.9.4	Custom Split Range End (CST ENd).....	62
8.9.5	Valve Flow Characterization Curves (CHAR) .....	62
8.9.6	User Set Characterization 5 Points (U5) .....	63
8.9.7	User Set Characterization 21 Points (U21) .....	64
8.9.8	Tight Shut Open (TSHUT OP) .....	65

8.9.9	Tight Shut Close (TSHUT CL) .....	66
8.9.10	Target Position Ramp Up Rate (RAMP UP) and Target Position Ramp Down Rate (RAMP dN) 67	
8.9.11	Digital Input Function (dIF) .....	68
8.9.12	Digital Input Logic (dI LOGIC).....	69
8.10	Output Configuration (OUT CFG) .....	70
8.10.1	Position Transmitter Direction (PTM NORM / REVS).....	70
8.10.2	Position Transmitter Zero / End (PTM ZERO / ENd).....	71
8.10.3	HART Feedback Direction (HT NORM / REVS).....	72
8.10.4	Back Calculation (bACKCAL oFF / on).....	73
8.10.5	Limit Switch Mode (LS MOdE oFF/ on) .....	73
8.10.6	Digital Output Function (dO1 or dO2 OFF / ...).....	75
8.10.7	Digital Output Logic (dO1 or dO2 LOGIC HI / Lo) .....	76
8.10.8	Analog Output Function (AOF OFF / ...) .....	77
8.10.9	Analog Output Logic (AO LOGIC Lo / HI).....	78
8.11	Device Configuration (dEV CFG).....	79
8.11.1	Action Setting (ACT REVS / dIR).....	79
8.11.2	Linear Lever Type (LEVt STd / AdT) .....	79
8.11.3	Linear Interpolation (ITP oFF / on).....	80
8.11.4	Lock of Parameters (Write Protect, W UNLOCK / LOCK) .....	80
8.11.5	Actual Position View Mode (View Mode, VI NORM / REVS) .....	81
8.11.6	Polling address setting (POL Addr) .....	81
8.11.7	Factory Reset (dEFAULT oFF / on).....	82
8.11.8	Positioner Self-Test (SELFTEST).....	83
8.12	Diagnosis Mode (dIAGNd).....	84
8.12.1	Default Alarm Settings .....	84
8.12.2	Process Status (PS) .....	86
8.12.3	Device Status (dS) .....	87
8.12.4	View Monitoring Counts (VI CNTS) .....	89
8.12.5	Diagnostic Limit Configuration (LIMt CFG).....	90
8.12.6	Reset Alarm Status (RST ALRM oFF / on).....	91
8.12.7	View Event Log (EVT LOG).....	92
8.12.8	Partial Stroke Test Record (View PST Result Record, PST RSLT) .....	93
8.12.9	PST Configuration (PST CFG) .....	94
8.12.10	Run PST (PST NOW) .....	95
8.12.11	Periodic PST Test (PST Schedule, PST SCHd oFF / on) .....	96
8.13	Position information (INFO) .....	96
8.14	Error codes during automatic calibration .....	98
8.15	Status and Alarm Code.....	99
<b>9</b>	<b>Main Software Map .....</b>	<b>103</b>



## 1 Introduction

### 1.1 General Information for the users

Thank you for purchasing Rotork YTC Limited products. Each product has been fully inspected after its production to offer you the highest quality and reliable performance. Please read the product manual carefully prior to installing and commissioning the product.

- Installation, commissioning, and maintenance of the product may only be performed by trained specialist personnel who have been authorized by the plant operator accordingly.
- The manual should be provided to the end-user.
- The manual can be altered or revised without any prior notice. Any changes in product's specification, design, and/or any components may not be printed immediately but until the following revision of the manual.
- When the manual refers to "**Valve Zero / Zero**" means the final valve position upon pneumatic pressure has been fully exhausted from positioner's OUT1 port. For example, the valve zero position may differ between linear direct and reverse actions. (DA/RA)
- The manual should not be duplicated or reproduced for any purpose without prior approval from Rotork YTC Limited, Gimpo-si, South Korea.
- In case of any other problems that are not stated in this manual, please make immediate contact to Rotork YTC Limited.
- Positioner is an accessory of the control valve, so please make sure to read the applicable instruction manual of the control valve prior to installation and operation.

### 1.2 Manufacturer Warranty

- For the safety, it is important to follow the instructions in the manual. Manufacturer will not be responsible for any damages caused by user's negligence.
- Any modifications or repairs to the product may only be performed if expressed in this manual. Injuries and physical damages caused by customer's modifying or repairing the product without a prior consultation with Rotork YTC Limited will not be compensated. If any alterations or modifications are necessary, please contact Rotork YTC Limited directly.
- The warranty period of the product is (18) months from the date of shipment unless stated otherwise. Date of shipment can be checked by providing the LOT NO. or SERIAL NO. to us.
- Manufacturer warranty will not cover products that have been subjected to abuse, accidents, alterations, modifications, tampering, negligence, misuse, faulty installation, lack of reasonable care, repair or service in any way that is not contemplated in the documentation for the product, or if the model or serial number has been altered, tampered with, defaced or removed; damages that occurs in shipment, due to act of God, failure due to power surge, or cosmetic damage. Improper or incorrectly performed maintenance will void this limited warranty.
- For detailed warranty information, please contact the corresponding local Rotork YTC Limited office or main office in South Korea.

### 1.3 Explosion Proof Warning & Specific Conditions of Use

Please ensure the unit is being used and installed in explosion proof certified environment.

- The positioners are Explosion proof construction for internal pressure.  
For detail information, refer to "2.7 Certifications"
- Explosion proof type of cables and gaskets should be used, when explosion gases are present at the installation site.
- KEEP COVER TIGHT WHILE CIRCUITS ARE ALIVE - GARDER LE COUVERCLE BIEN FERME TANT QUE LES CIRCUITS SONT SOUS TENSION.
- Power should be turned off completely when opening product's cover. When opening the cover, ensure that there is no power remaining in any electrical parts nearby.
- The positioners have 2 ports for power connection. Explosion proof type wires and packing should be used. Blind plug is required when any port is not being used.
- Ring terminal with surface area of more than 1.25mm<sup>2</sup> with M4 spring washer should be used to connect the power.
- For external ground terminal, ring terminal with surface area of more than 5.5mm<sup>2</sup> should be used.
- POTENTIAL ELECTROSTATIC CHARGING HAZARD: SEE INSTRUCTIONS - PISQUE POTENTIEL DE CHARGE ELECTROSTATIQUE. VOIR LES INSTRUCTIONS. There is risk of explosion due to electro-static charge. Static electricity charge may develop when cleaning the product with a dry cloth. It is imperative to avoid static electricity charge in the hazardous environment. If cleaning the surface of the product is needed, must use wet clothes.
- A SEAL SHALL BE INSTALLED WITHIN 50 mm OF THE ENCLOSURE - UN SCCELLEMENT DOIT ETRE INSTALLEA MOINS DE 50 mm DU BOITIER.
- Seal required within 50mm of enclosure.
- Consult the manufacturer for dimensional information on the flameproof joint for repair.
- To maintain TYPE 4X(FM & CSA) and IP66 rating, when installing threaded conduit, use type PTFE tape according to instructions.
- Tapped Exhaust option is used when it is required to vent away Group D, Div/Group IIA, Zone gases to a safe area.
- "FM/CSA approval for Division hazardous location installations - Group D gases are allowed as the process medium" under the following conditions:
  - Maximum supply pressure must not exceed 101 PSIG (7 BAR)
  - The gas must be compatible with the wetted parts of the positioner.
- CSA only :
  - DO NOT OPEN WHEN EXPLOSIVE ATMOSPHERE IS PRESENT.  
French : NE PAS OUVRIR EN PRÉSENCE D'UNE ATMOSPHÈRE EXPLOSIVE.
  - DO NOT OPEN ENERGIZED.  
French : NE PAS OUVRIR SOUS TENSION.
  - SEAL ENTRIES WITHIN '450 mm' OF ENCLOSURE.  
French : SCELLER LES ENTRÉES À MOINS DE '450 mm' DE L'ENCEINTE.



- WARNING — POTENTIAL STATIC HAZARD. CLEAN ONLY WITH A WATER WETTED CLOTH.  
French : RISQUE D'ÉLECTRICITÉ STATIQUE POTENTIEL. NETTOYER SEULEMENT AVEC UN LINGE IMBIBÉ D'EAU.
- WARNING — THIS EQUIPMENT SHALL NOT BE OPERATED IN HAZARDOUS LOCATIONS WHERE CARBON DISULFIDE MIGHT BE PRESENT.  
French : CET APPAREIL NE DOIT PAS ÊTRE UTILISÉ DANS DES ENDROITS DANGEREUX OÙ LA PRÉSENCE DE 'DISULFURE DE CARBONE' EST POSSIBLE.
- Special conditions for safe use :  
The ambient temperature range is from -30°C to +70°C for temperature class T6(T85°C ) or -30°C to +80°C for temperature class T5(T100°C).  
With silicone gasket material the minimum ambient temperature can be extended to -40°C.  
Hazardous area with carbon disulfide shall be excluded.
- Condition of use (CSA) :
  - 1) This equipment may only be powered by a power supply unit with a limited energy electric circuit in accordance with CAN/CSA C22.2 No. 61010-1-12 and ANSI/UL 61010-1, or Class 2 as defined in the Canadian Electrical Code C22.1, Section 16-200 and/or National Electrical Code (NFPA 70), article 725.121.
  - 2) The ambient temperature range is from -30°C to +70° C for temperature class T6 (T85°C), or -30°C to +80°C for temperature class T5 (T100°C). With silicone gasket material the minimum ambient temperature can be extended to -40°C.
  - 3) The powder coated external surfaces of this equipment may become a spark ignition hazard in the presence of static electricity. The enclosure shall be cleaned only with a damp cloth, and the equipment shall be mounted to avoid building static electric charge from nonconductive process flow, strong air currents, or other potential charging through friction.
  - 4) This equipment shall not be used in hazardous locations where CARBON DISULFIDE might be present.



## 2 Product Description

### 2.1 General

The smart positioner accurately controls valve stroke in response to an input signal of 4 ~ 20 mA from the controller. Built-in micro-processor optimizes the positioner's performance and provides unique functions such as **Auto-Calibration, PID Control, and HART Protocol Communications**.

### 2.2 Main Features and Functions

- The LCD monitoring and button operation can be performed without opening the cover which allows use of various functions of the positioner such as parameter adjustment in explosive gas atmosphere.
- User will easily understand the method of using 4 buttons because it works same in all mode of firmware interfaces.
- When unexpected situation like momentary blackout happens, our positioner boot-time only take 0.5 second and this can minimize the travel of valve which consequentially increase the safety of system.
- Positioner operates normally even there are sudden changes in supply pressure and / or high vibration environment.
- The method of Auto Calibration is very simple.
- As an advantage of having very low air consumption, it could greatly reduce operating costs in large-scale plants.
- It is compatible with most of controllers.
- Variable orifice can be used even to minimize the hunting occurrence and optimize operating conditions.
- Various information about positioner can be processed by HART communication(HART Option)
- "EDD and FDI files required for HART communication can be downloaded from our website ([www.ytc.co.kr](http://www.ytc.co.kr)) or FieldComm Group ([www.fieldcommgroup.org](http://www.fieldcommgroup.org)). When using the FieldComm Group website, please search for the Product Name on YT-3XXX."
- Valve system becomes more stable by outputting analog feedback signal.
- Different valve characteristics can be adjusted – Linear, Quick Open, Equal Percentage, and User Set which user can make 5 or 21 points characterizations.
- Tight Shut – Close and Shut - Open can be set.
- PID parameters can be adjusted in the field without any additional communicator.
- A/M switch can be used to direct supply air to the actuator or to manually operate the positioner or valve without any signal.
- Split range 4 ~ 12 mA or 12 ~ 20 mA can be set.
- Operating temperature for positioners is -30 ~ 85 °C or -40 ~ 85 °C (Please check certified explosion proof ambient temperature)
- Hand calibration function can set Zero point or End point manually.
- It has Type 4, 4X(CSA), IP66 protection grade.

- Polyester powder coating resists the corrosion process. (except YT-3450).
- Maintenance of the positioner is easy because of modularized inner structure.
- SIL2 certified.(For more information, see SIL Safety Instruction on homepage)
- Suitable for use with methane or natural gas supply pressure medium for FM/CSA (only A & AG of Explosion proof of Product code)
- The AG option in the product code has the tapped exhaust ports to carry the gas vented from the positioner to a safe location when the positioner is installed indoors to use methane or natural gas as a process medium.

### 2.3 Label Description

- MODEL : Indicates the model number of the positioner.
- SUFFIX : Indicates any options.
- SERIAL NO. : Indicates unique serial number.
- MONTH.YEAR : Indicates manufactured month and year
  
- EXPLOSION PROOF RATING : Indicates certified explosion proof grade
- INGRESS PROTECTION : Indicates enclosure protection grade.
- INPUT : Indicates input signal range.
- AMBIENT TEMP. : Indicates the allowable ambient temperature.
- SUPPLY : Indicates the supply pressure range.

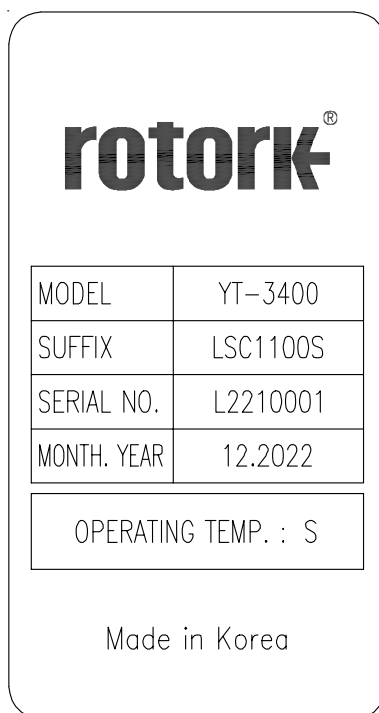

Fig. L-1: YT-3400, 3450 sticker label

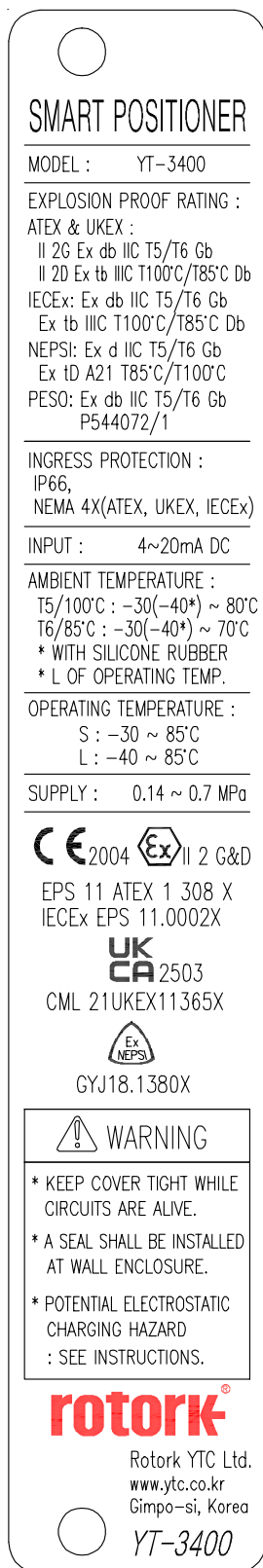

Fig. L-2: YT-3400 metal label (ATEX, IECEx, UKEX, NEPSI, PESO)

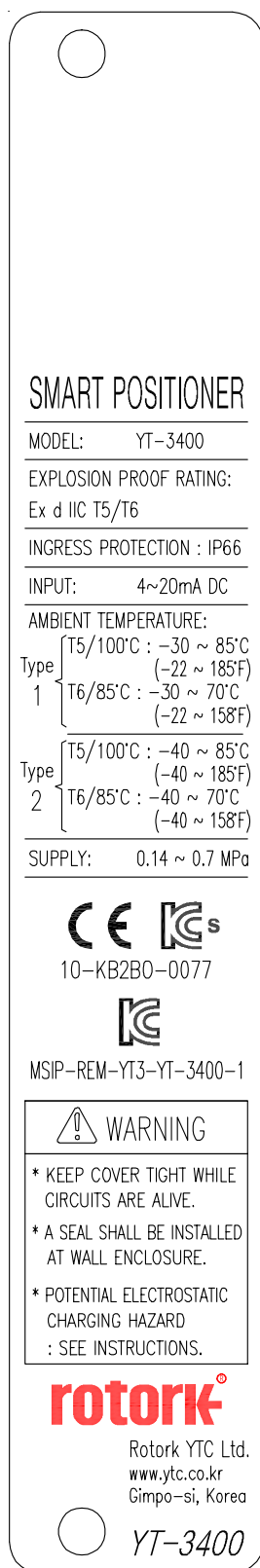

Fig. L-3: YT-3400 metal label (KCs)

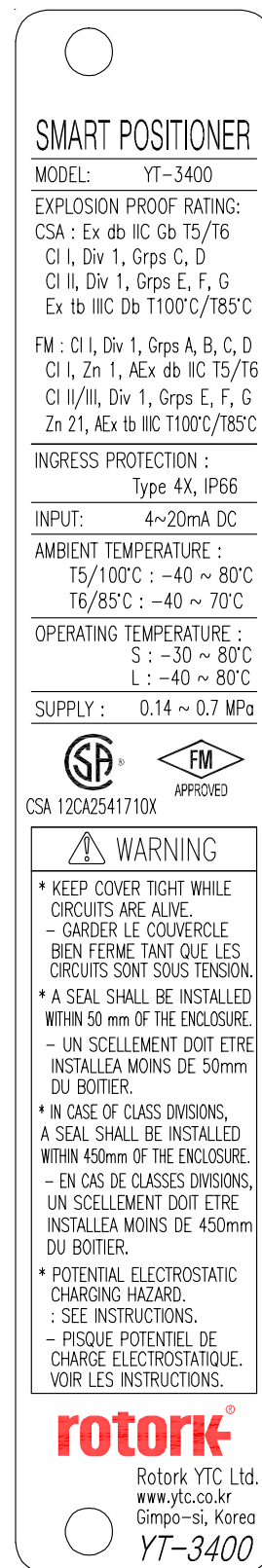

Fig. L-4: YT-3400, 3450 metal label (FM, CSA)

Электropневматический  
позиционер

---

Модель YТ-3400

---

Тип взрывозащиты:  
1Ex d IIC T6/T5 Gb X  
Ex tb IIC T85°C/T100°C Db X

---

Пылевлагозащита IP 66

---

Аналог.  
сигнал 4~20mA DC

---

Диапазон температур  
окружающей среды  
T5/100°C :  
-40°C to +80°C  
T6/85°C :  
-40°C to +70°C  
(\*см. Руководство пользователя)

---

Пневмопитание  
0.14 ~ 0.7 МПа

---

Ex EAC

RU C-KR.AM02.B.00043/19

---

⚠ ВНИМАНИЕ

\* КРЫШКА ДОЛЖНА БЫТЬ  
ЗАКРЫТА ПРИ ВКЛЮЧЕНИИ  
\* УБЕДИТЬСЯ В НАЛИЧИИ  
УПЛОТНЕНИЙ ПРИ  
ЗАКРЫТИИ КРЫШКИ  
\* ОПАСНОСТЬ ОБРАЗОВАНИЯ  
ЭЛЕКТРОСТАТИЧЕСКОГО  
ЗАРЯДА : СМ. ИНСТРУКЦИЮ

---

rotork®

Rotork YTC Ltd.  
www.ytc.co.kr  
Gimpo-si, Korea

○ YТ-3400

Fig. L-5: YТ-3400, 3450 labels (EAC)

rotork®

Модель	YТ-3400
Кодировка	RSE1100L
Серийный №.	C2110001
Месяц, Год	03.2021

Сделано в Корее

SMART POSITIONER

---

MODEL : YТ-3450

---

EXPLOSION PROOF RATING :  
ATEX & UKEX :  
II 2G Ex db IIC T5/T6 Gb  
II 2D Ex tb IIC T100°C/T85°C Db  
IECEX : Ex db IIC T5/T6 Gb  
Ex tb IIC T100°C/T85°C Db  
NEPSI : Ex d IIC T5/T6 Gb  
Ex tD A21 T85°C/T100°C  
KCs : Ex d IIC T5/T6 Gb  
Ex tb IIC T100°C/T85°C  
PESO : Ex db IIC T5/T6 Gb  
P544071/1

---

INGRESS PROTECTION :  
IP66,  
NEMA 4X(ATEX, UKEX, IECEX)

---

INPUT : 4~20mA DC

---

AMBIENT TEMPERATURE :  
T5/100°C : -30(-40\*) ~ 80°C  
T6/85°C : -30(-40\*) ~ 70°C  
\* WITH SILICONE RUBBER  
\* L OF OPERATING TEMP.

---

OPERATING TEMPERATURE :  
S : -30 ~ 85°C  
L : -40 ~ 85°C

---

SUPPLY : 0.14 ~ 0.7 MPa

---

CE 2004 Ex II 2 G&D  
EPS 11 ATEX 1 308 X  
IECEX EPS 11.0002X

UK  
CA 2503  
CML 21UKEX11365X

Ex  
NEPSI GYJ18.1380X

KCs15-KA2B0-0366

---

⚠ WARNING

\* KEEP COVER TIGHT WHILE  
CIRCUITS ARE ALIVE.  
\* A SEAL SHALL BE INSTALLED  
AT WALL ENCLOSURE.  
\* POTENTIAL ELECTROSTATIC  
CHARGING HAZARD  
: SEE INSTRUCTIONS.

---

rotork®

Rotork YTC Ltd.  
www.ytc.co.kr  
Gimpo-si, Korea

○ YТ-3450

Fig. L-6: YТ-3450 metal label  
(ATEX, IECEX, UKEX, KCs, NEPSI, PESO)

Posicionador de  
Válvula

---

MODELO : YT-3400

---

MARCAÇÃO :  
Ex db IIC T6/T5 Gb  
Ex tb IIC T85°C/T100°C Db

---

GRAU DE PROTEÇÃO : IP66  
NEMA 4X

---

SINAL DE ENTRADA : 4~20mA DC

---

TEMPERATURA AMBIENTE:  
T5/100°C : -20(-40\*) ~ 80°C  
T6/85°C : -20(-40\*) ~ 70°C  
\* COM BORRACHA DE SILICONE  
\* L DE TEMP OPERAÇÃO

---



TEMPERATURA DE OPERAÇÃO:  
(NÃO À PROVA DE EXPLOSAÇÃO)  
S : -30 ~ 85°C  
L : -40 ~ 85°C

---

PRESSÃO DE ALIMENTAÇÃO  
0.14 ~ 0.7 MPa

---

**Segurança**

DNP 17.0068 X

---

 **ATENÇÃO**

\* NÃO ABRA QUANDO ENERGIZADO

\* UM SELO SERÁ INSTALADO NA PAREDE.

\* POTENCIAL RISCO DE CARGA ELETROSTÁTICA : VER INSTRUÇÕES.

---

**rotork®**

Rotork YTC Ltd.  
www.ytc.co.kr  
Gimpo-si, Korea

---

 **YT-3400**

**rotork®**

MODELO	YT-3400
SUFIXO	RSC1100S
NÚMERO DE SÉRIE	L2210001
ANO	12.2022
TEMPERATURA DE OPERAÇÃO	<b>S</b>

Made in Korea

Fig. L-7: YT-3400, 3450 labels (INMETRO)

智能阀门定位器

型号: YT-3400

防爆等级:  
CCC和NEPSI:  
Ex d IIC T5/T6 Gb  
Ex tD A21 IP66 T85°C/T100°C

UKEX和ATEX:  
II 2G Ex db IIC T5/T6  
II 2D Ex tb IIIC T100°C/T85°C

IECEX: Ex db IIC T5/T6  
Ex tb IIIC T100°C/T85°C



防护等级: IP66, NEMA 4X

输入: 4~20mA DC

防爆环境温度:  
T5/100°C: -20(-40\*) ~ 80°C  
T6/85°C: -20(-40\*) ~ 70°C  
\* 带硅橡胶  
\* 低温型防爆环境温度

工作温度(不防爆型):  
S: -30 ~ 85°C  
L: -40 ~ 85°C



供给压力: 0.14 ~ 0.7 MPa

GYJ18.1380X



CML 21UKEX11365X

EPS 11 ATEX 1 308 X  
IECEX EPS 11.0002X

 **警告**

- \* 电源接通时请勿开盖。
- \* 密封应安装在外壳的50mm以内。
- \* 潜在的静电充电危险: 请参阅说明。



Rotork YTC Ltd.  
www.ytc.co.kr  
金浦市, 韩国



rotork®

型号	YT-3400
后缀	RDZ1500S
序列号	C2110001
月.年	03.2021

工作温度类型: S

韩国制造

智能阀门定位器

型号: YT-3450

防爆等级:  
CCC和NEPSI:  
Ex d IIC T5/T6 Gb  
Ex tD A21 IP66 T85°C/T100°C

UKEX和ATEX:  
II 2G Ex db IIC T5/T6  
II 2D Ex tb IIIC T100°C/T85°C

IECEX: Ex db IIC T5/T6  
Ex tb IIIC T100°C/T85°C

KCs: Ex d IIC T5/T6  
Ex tb IIIC T100°C/T85°C



防护等级: IP66, NEMA 4X

输入: 4~20mA DC

防爆环境温度:  
T5/100°C: -20(-40\*) ~ 80°C  
T6/85°C: -20(-40\*) ~ 70°C  
\* 带硅橡胶  
\* 低温型防爆环境温度

工作温度(不防爆型):  
S: -30 ~ 85°C  
L: -40 ~ 85°C



供给压力: 0.14 ~ 0.7 MPa

GYJ18.1380X



CML 21UKEX11365X

EPS 11 ATEX 1 308 X  
IECEX EPS 11.0002X



15-KA2BO-0366

 **警告**

- \* 电源接通时请勿开盖。
- \* 密封应安装在外壳的50mm以内。
- \* 潜在的静电充电危险: 请参阅说明。



Rotork YTC Ltd.  
www.ytc.co.kr  
金浦市, 韩国

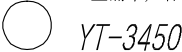

Fig. L-8: YT-3400 labels (CCC)

Fig. L-9: YT-3450 metal label (CCC)

2.4 Product Code

YT-3400 / 3450 series follows suffix symbols as follows.

YT-3400 / 3450 1 2 3 4 5 6 7 8

<span style="border: 1px solid black; padding: 2px 5px;">1</span> Motion Type	L : Linear R : Rotary				
<span style="border: 1px solid black; padding: 2px 5px;">2</span> Acting type	S : Single D : Double				
<span style="border: 1px solid black; padding: 2px 5px;">3</span> Explosion Proof	<sup>1)</sup> C : ATEX, IECEx, INMETRO, KCs, NEPSI, UKEX, PESO A : FM, CSA AG : FM, CSA + Tapped Exhaust E : EAC Z : CCC				
<span style="border: 1px solid black; padding: 2px 5px;">4</span> Lever Type	<table border="1" style="width: 100%; border-collapse: collapse;"> <tr> <td style="width: 30%; text-align: center; vertical-align: middle;">Linear</td> <td>                             1 : 10 ~ 40 mm                              2 : 20 ~ 70 mm                              3 : 50 ~ 100 mm                              4 : 100 ~ 150 mm                         </td> </tr> <tr> <td style="width: 30%; text-align: center; vertical-align: middle;">Rotary</td> <td>                             1 : M6 x 34L                              2 : M6 x 63L                              3 : M8 x 34L                              4 : M8 x 63L                              5 : Namur                         </td> </tr> </table>	Linear	1 : 10 ~ 40 mm 2 : 20 ~ 70 mm 3 : 50 ~ 100 mm 4 : 100 ~ 150 mm	Rotary	1 : M6 x 34L 2 : M6 x 63L 3 : M8 x 34L 4 : M8 x 63L 5 : Namur
Linear	1 : 10 ~ 40 mm 2 : 20 ~ 70 mm 3 : 50 ~ 100 mm 4 : 100 ~ 150 mm				
Rotary	1 : M6 x 34L 2 : M6 x 63L 3 : M8 x 34L 4 : M8 x 63L 5 : Namur				
<span style="border: 1px solid black; padding: 2px 5px;">5</span> Conduit - Air Connection Type	1 : G 1/2 – Rc 1/4 (N/A for FM & CCC, N/A for YT-3450) 2 : G 1/2 – 1/4 NPT (N/A for FM & CCC) 3 : G 1/2 – G 1/4 (N/A for FM & CCC, N/A for YT-3450) 4 : M20x1.5P – 1/4 NPT (N/A for YT-3450) 5 : 1/2 NPT – 1/4 NPT				
<span style="border: 1px solid black; padding: 2px 5px;">6</span> Communication	0 : None 2 : + HART <sup>2)</sup> 5 : + HART with Enhanced Diagnostics & DI / DO ※ Digital Output(DO) operation is configurable in synchronization with specific event or alarm including limit switch function.				
<span style="border: 1px solid black; padding: 2px 5px;">7</span> Option	0 : None 1 : + 4 to 20 mA feedback 2 : + Limit Switch <sup>3)</sup> 3 : + 4 to 20 mA feedback + Limit Switch <sup>4)</sup>				

<b>8</b> Operating Temp. (Non-explosion proof) <sup>5)</sup>	S : -30 ~ 85 °C (-22 ~ 185 °F, except EAC)
	FM & CSA : -30 ~ 80 °C (-22 ~ 176 °F)
	L : -40 ~ 85 °C (-40 ~ 185 °F)
	FM & CSA : -40 ~ 80 °C (-40 ~ 176 °F)
A : -55 ~ 85 °C (-67 ~ 185 °F, only EAC)	

- 1) Please put the name of certificate in a purchase order.
- 2) DO (Digital Output) already is included in this option, so it can't be selected with 2 or 3 of **7** Option together.
- 3) 4) Limit switch: DC 24V (50 mA) and transistor type.
- 5) This option is just the normal operating temperature of the product and is not related to explosion proof temperature. See "2.7 Certificates" for explosion proof temperature.

## 2.5 Product Specification

Model	YT-3400		YT-3450	
<b>Housing Material</b>	Aluminum		Stainless Steel 316	
<b>Motion Type</b>	Linear	Rotary	Linear	Rotary
<b>Acting Type</b>	Single / Double			
<b>Input Signal</b>	4 ~ 20 mA DC			
<b>Minimum Current Signal</b>	Standard : 3.6 mA PTM Internal : 3.7 mA HART or HART+PTM Internal : 3.8 mA			
<b>Supply Pressure</b>	0.14 ~ 0.7 MPa (1.4 ~ 7 bar)			
<b>Stroke</b>	10~150 mm	55 ~ 110°	10~150 mm	55 ~ 110°
<b>Impedance</b>	Max. 450 Ω @ 20 mA DC			
<b>Air Connection</b>	Rc 1/4 or G 1/4 or 1/4 NPT		1/4 NPT	
<b>Gauge Connection</b>	Rc 1/8 or 1/8 NPT		1/8 NPT	
<b>Conduit Entry</b>	G 1/2(N/A for FM & CCC) or 1/2 NPT or M20x1.5P		G 1/2(N/A for FM & CCC) or 1/2 NPT	
<b>Tapped Exhaust (Only AG option of Product code)</b>	1/4 NPT			
<b>Ingress Protection</b>	Type 4, 4X(CSA), IP66			
<b>Explosion Proof</b>	Flameproof enclosure. Refer to "2.7 Certifications"			
<b>Operating Temperature (Non-explosion proof)</b>	<b>Standard Type</b>	-30 ~ 85 °C (-22 ~ 185 °F, except EAC) FM & CSA : -30 ~ 80 °C (-22 ~ 176 °F)		
	<b>Low Temp. Type</b>	-40 ~ 85 °C (-40 ~ 185 °F) FM & CSA : -40 ~ 80 °C (-40 ~ 176 °F)		
	<b>Arctic Temp. Type</b>	-55 ~ 85 °C (-67 ~ 185 °F, only EAC)		





## 2.7 Certifications

※ All certifications below are posted on Rotork YTC Limited homepage([www.ytc.co.kr](http://www.ytc.co.kr)).

### ➤ **KCs (Korea)**

Type : Explosion proof construction for internal pressure

Rating : Ex d IIC T5/T6 IP66 (YT-3400)

Ex d IIC T5/T6, Ex tb IIIC T85°C/T100°C (YT-3450)

Certification No. : 10-KB2BO-0077 (YT-3400)

15-KA2BO-0366 (YT-3450)

Ambient temperature : -40 ~ +70°C(T6), -40 ~ +85°C(T5) ← YT-3400

-40 ~ +70°C(T6), -40 ~ +80°C(T5) ← YT-3450

### ➤ **NEPSI**

Type : Explosion proof construction for internal pressure

Rating : Ex d IIC T5/T6 Gb, Ex tD A21 IP66 T85°C/T100°C

Certification No. : GYJ18.1380X

Ambient temperature : -40 ~ +70°C(T6), -40 ~ +80°C(T5)

### ➤ **ATEX**

Type : Explosion proof construction for internal pressure

Rating : II 2G Ex db IIC T5/T6 Gb, II 2D Ex tb IIIC T85°C/T100°C Db

Certification No. : EPS 11 ATEX 1 308 X

Ambient temperature : -40/-30 ~ +70°C T6(T85°C), -40/-30 ~ +80°C T5(T100°C)

### ➤ **IECEX**

Type : Explosion proof construction for internal pressure

Rating : Ex db IIC T5/T6 Gb, Ex tb IIIC T85°C/T100°C Db

Certification No. : IECEX EPS 11.0002X

Ambient temperature : -40/-30 ~ +70°C T6(T85°C), -40/-30 ~ +80°C T5(T100°C)

### ➤ **CSA**

Type : Explosion proof construction for internal pressure

Rating : Ex db IIC Gb T5 or T6

Class I, Division 1, Groups C, D

Class II, Division 1, Groups E, F and G

Ex tb IIIC Db T100°C/T85°C

Type 4, 4X ; IP66

Certification No. : CSA 12CA2541710X

Ambient temperature : -40/-30°C to +70°C(T6), -40/-30°C to +80°C(T5)

➤ **FM**

Type : Explosion proof construction for internal pressure

Rating : Class I, Div 1, Groups ABCD; T6/T5

Class II/III, Div 1, Groups EFG; T6/T5

Class I, Zone 1, AEx db IIC T6/T5

Zone 21 AEx tb IIIC

T85°C Ta=-40°C to +70°C , T100°C Ta=-40°C to +80°C; Type 4X/IP66

Certification No. : FM16US0132X

Ambient temperature : (T6) -40°C to +70°C, (T5) -40°C to +80°C

➤ **EAC (TRCU)**

Type : Explosion proof construction for internal pressure

Rating : 1Ex d IIC T6/T5 Gb X, Ex tb IIIC T85°C/T100°C Db X, IP66

Certification No. : RU C-KR.MIO62.B.04778

Ambient temperature : -55 ~ +70°C (T6/T85°C), -55 ~ +80°C (T5/T100°C)

➤ **INMETRO (Brazil)**

Rating : Ex db IIC T5/T6 Gb IP66, Ex tb IIC T85°C/T100°C Db IP66

Certification No. : DNV 17.0068 X

Ambient temperature : -40 ~ +70°C (T6), -40 ~ +80°C (T5)

➤ **CCC (China)**

Type : Explosion proof construction for internal pressure

Rating : Ex d IIC T5/T6 Gb, Ex tD A21 IP66 T85°C/T100°C

Certification No. : 2020322307000616

Ambient temperature : -20(-40) ~ +70°C T6(T85°C), -20(-40) ~ +80°C T5(T100°C)

➤ **UKEX**

Type : Explosion proof construction for internal pressure

Rating : II 2G Ex db IIC T5/T6 Gb, II 2D Ex tb IIIC T85°C/T100°C Db

Certification No. : CML 21UKEX11365X

Ambient temperature : -40/-30 ~ +70°C T6(T85°C), -40/-30 ~ +80°C T5(T100°C)

➤ **PESO (India)**

Type : Explosion proof construction for internal pressure

Rating : Ex db IIC T5/T6 Gb, Ex tb IIIC T85°C/T100°C Db

Certification No. : P544072/1 (YT-3400)

P544071/1 (YT-3450)

Ambient temperature : -40/-30 ~ +70°C T6(T85°C), -40/-30 ~ +80°C T5(T100°C)

➤ **SIL2 (in a redundant structure up to SIL 3)**

Intended application : Safety function is defined as to move into fail-safe-position, when signal to positioner is interrupted.

Certification No. : 968/V 1155.00/20

➤ **Electromagnetic Compatibility (EMC)**

- EMC directive 2014/30/EC from April 2016

- EC Directive for CE conformity marking

2.8 Parts and Assembly

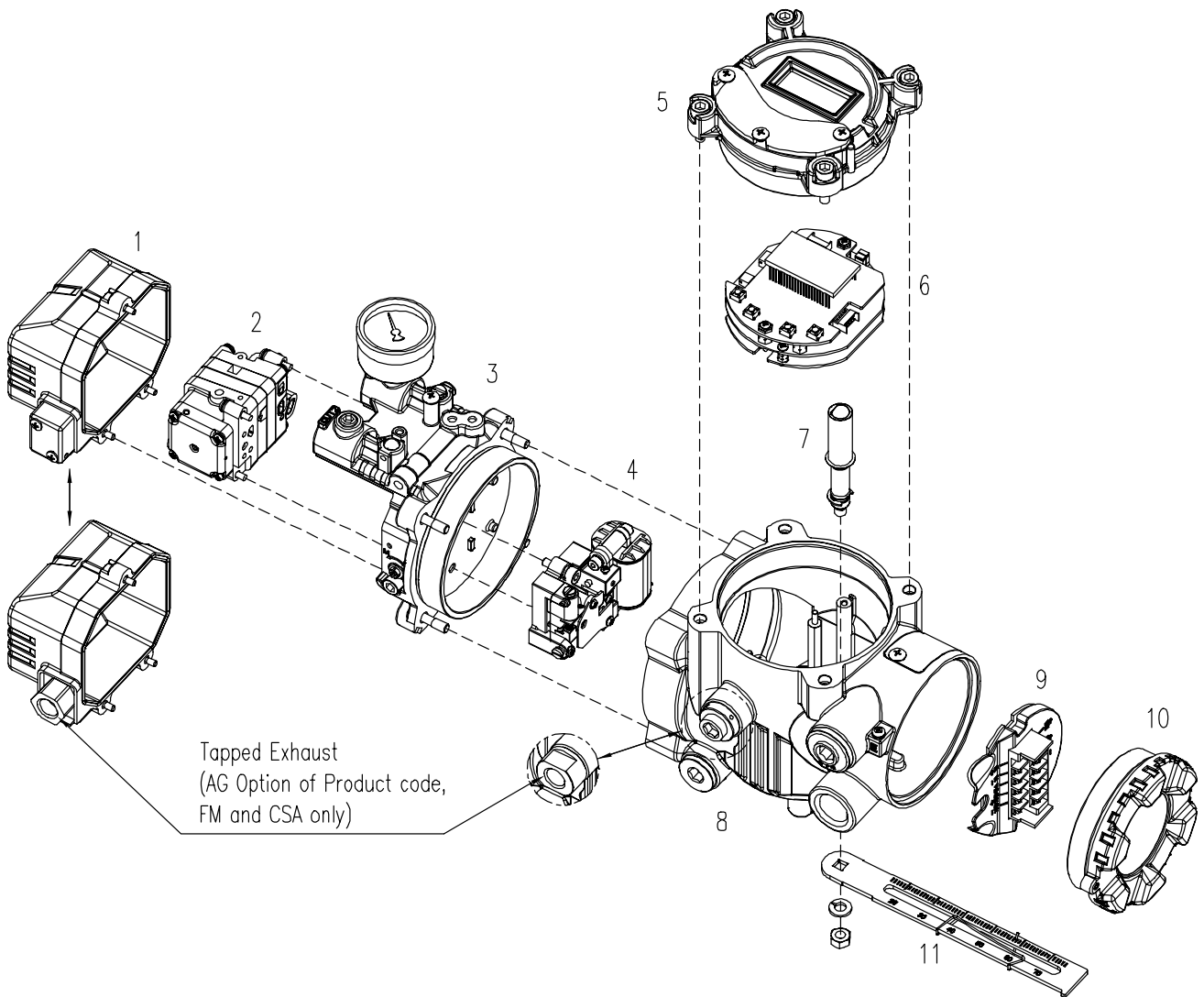

Fig. 2-1: Exploded view

- |                 |                    |
|-----------------|--------------------|
| 1. Pilot Cover  | 7. Main Shaft      |
| 2. Pilot Unit   | 8. Main Body       |
| 3. Manifold     | 9. Terminal PCB    |
| 4. Torque Motor | 10. Terminal Cover |
| 5. Main Cover   | 11. Feedback Lever |
| 6. Main PCB     |                    |

2.9 Product Dimension

2.9.1 YT-3400

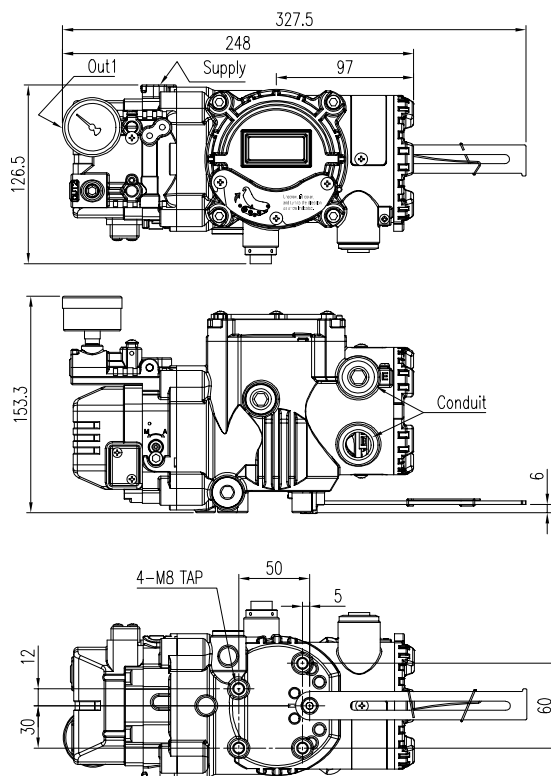

Fig. 2-2: YT-3400L (Linear type)

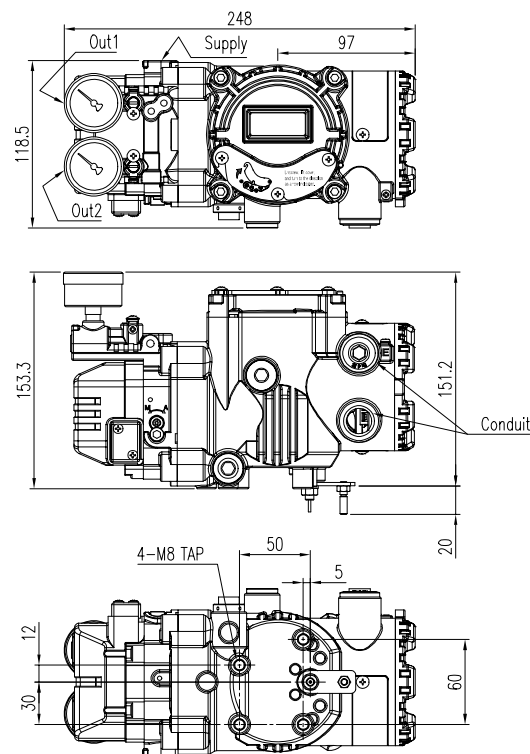

Fig. 2-3: YT-3400R (Rotary, Fork lever type)

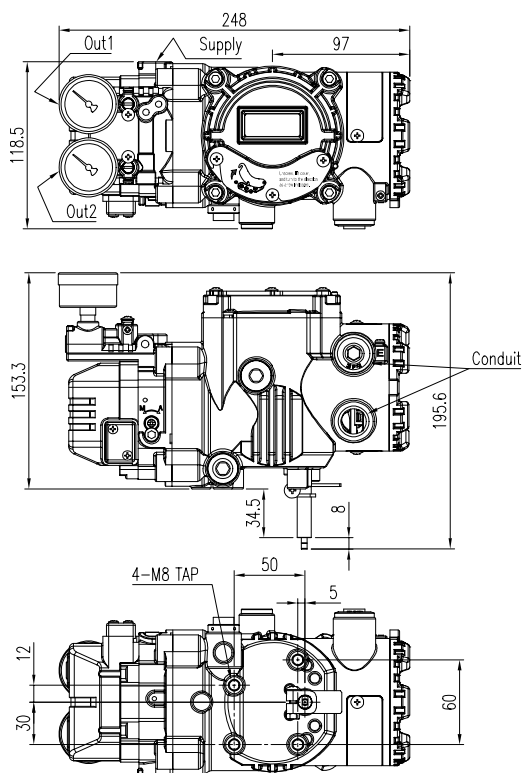

Fig. 2-4: YT-3400R (Rotary, Namur type)

2.9.2 YT-3450

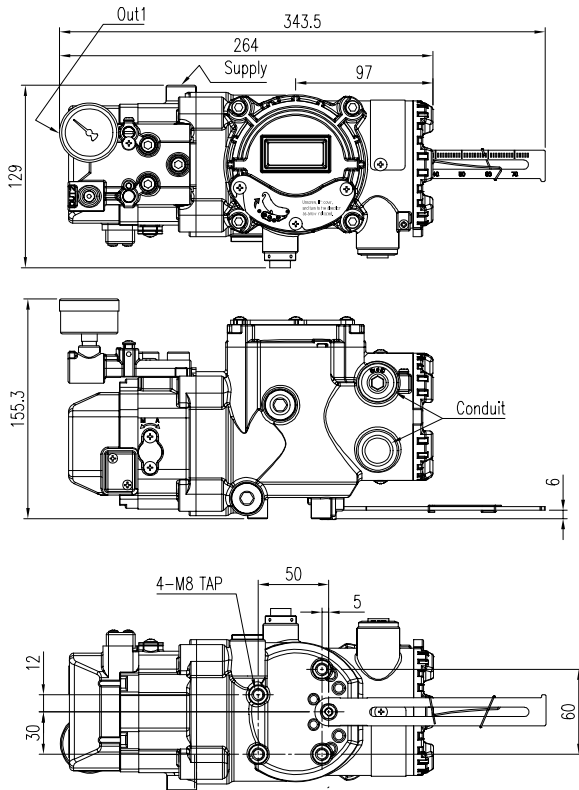

Fig. 2-5: YT-3450L (Linear type)

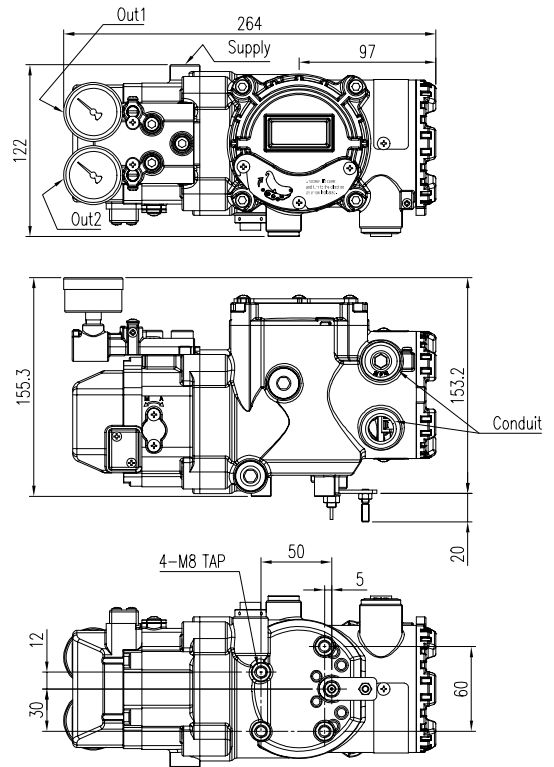

Fig. 2-6: YT-3450R (Rotary, Fork lever type)

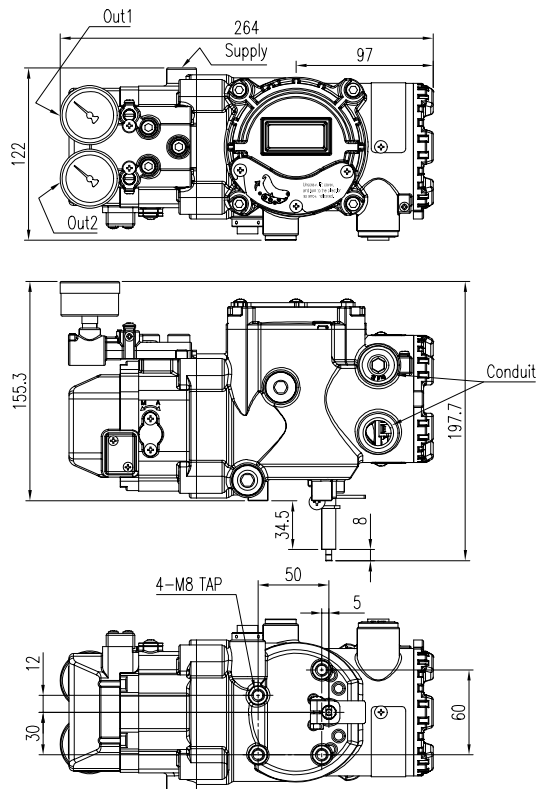

Fig. 2-7: YT-3450R (Rotary, Namur type)

### 3 Installation

#### 3.1 Safety

When installing a positioner, please ensure to read and follow safety instructions.



- The maximum use altitude: 2000 m above sea level.
- Any input or supply pressures to valve, actuator, and / or to other related devices must be turned off.
- Use bypass valve or other supportive equipment to avoid entire system “shut down”.
- Ensure there is no remaining pressure in the actuator.
- YT-3400 and 3450 have two drain ports to be used for internal condensation. Please use larger drain plug for the condensation and block other remaining port with blind plug.

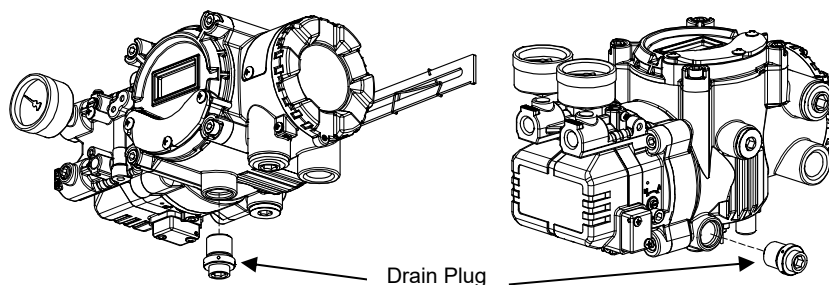

Fig. 3-1: Location of drain plug according to orientation of positioner's mounting

- After assembling the drain plug at the correct hole, make sure the positioner must be installed as shown below. Otherwise, the condensation water could cause damages to PCB.

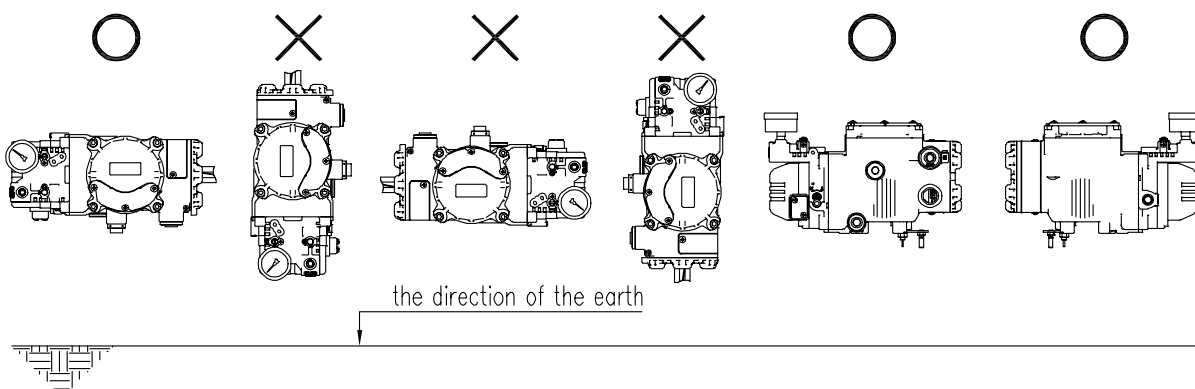

Fig. 3-2: The correct positions of a vent cover

- ※ Installed in accordance with the National Electrical Code(NEC), ANSI/NFPA 70, or CEC Part 1 as applicable.(FM & CSA approved product)

### 3.2 Tools for installation

- Hex key set for hex socket cap bolts
- (+) & (-) Screw drivers
- Spanners for hexagonal-head bolts

### 3.3 Linear positioner Installation

Linear positioner should be installed on linear motion valves such as globe or gate type which uses spring return type diaphragm or piston actuators.

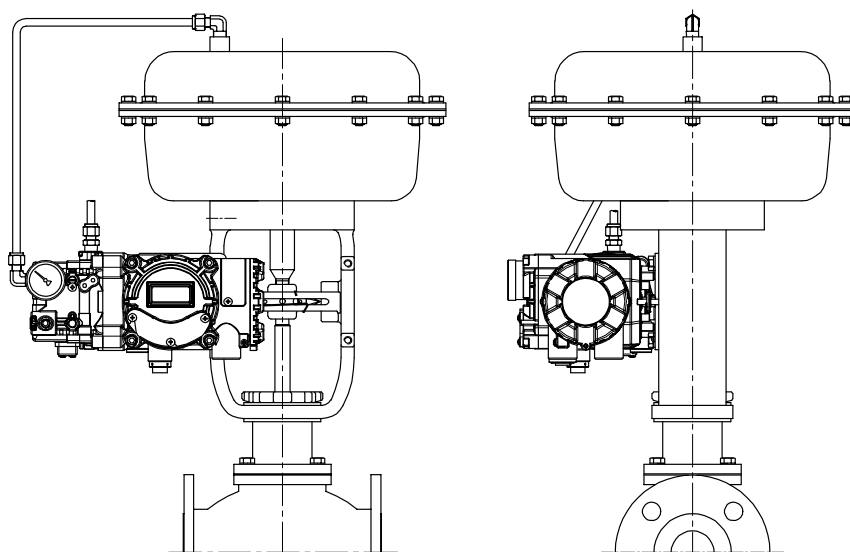

Fig. 3-3: Installation example

Before proceeding with the installation, ensure following components are available.

- Positioner
- Feedback lever and lever spring
- M6 nut and spring washer (fastening feedback lever to a main shaft)
- Bracket, bolts and washers for positioner – not supplied with the positioner
- Connection bar – not supplied with the positioner

#### 3.3.1 Safety

Proper bracket must be made in order to adapt the positioner on the actuator yoke.

Please consider following important points when a bracket is being designed.

- Positioner's feedback lever must be vertical to the valve stem at 50 % of the valve stroke.
- The connection bar of the actuator clamp for the feedback lever should be installed in such a way that the valve stroke length coincides with the corresponding figure in "mm" marked on the feedback lever. Improper setting may cause poor linearity





### 3.3.2 Positioner Installation Steps

- 1) Assemble the positioner with the bracket made in previous step by fastening the bolts. The bolt size is M8 x 1.25P.

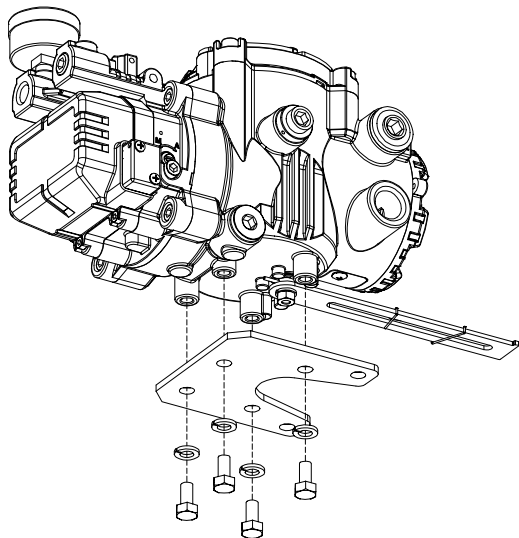

Fig. 3-4: Attaching the positioner to bracket

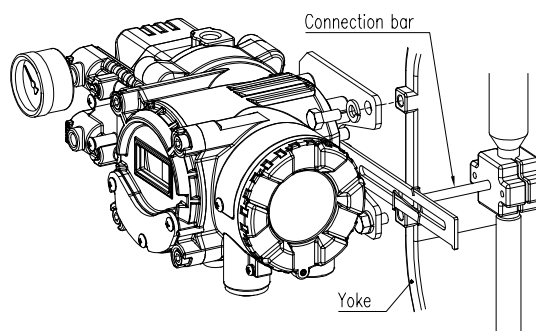

Fig. 3-5: Attaching the bracket to actuator yoke

- 2) Attach the positioner with the bracket to the actuator yoke – **DO NOT TIGHTEN THE BRACKET COMPLETELY.**
- 3) Connect connection bar to the actuator clamp. The hole gap on the feedback lever is 6.5 mm so the connection bar's outer diameter should be less than or equal to 6 mm.
- 4) Connect an air-filter regulator to the actuator temporarily. Supply enough air pressure to the actuator in order to position the valve stroke at 50 % of the total stroke.

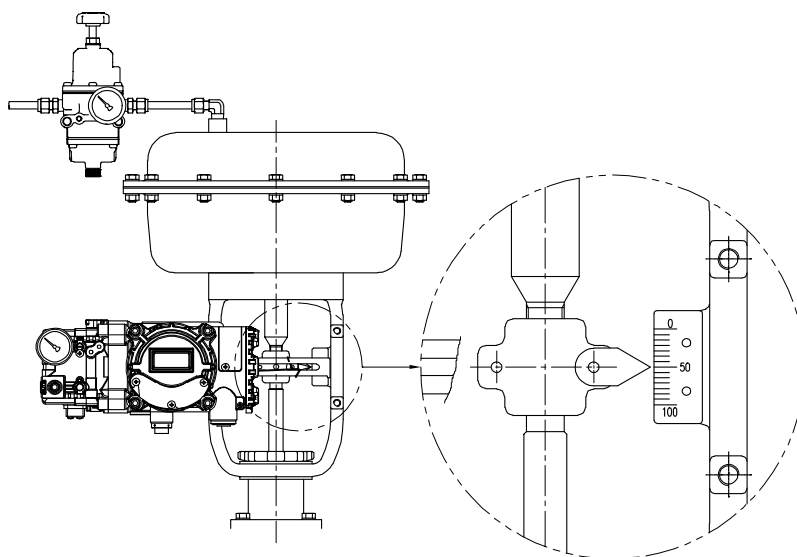

Fig. 3-6 Positioning the valve at 50 % of the total stroke

- 5) Insert the connection bar between the feedback lever and lever spring. The connection bar must be located upward from the lever spring as shown the below left figure. If it is located downward from the lever spring as shown the below right figure, the connection bar or the lever spring will be worn out quickly because of excessive strong tension.

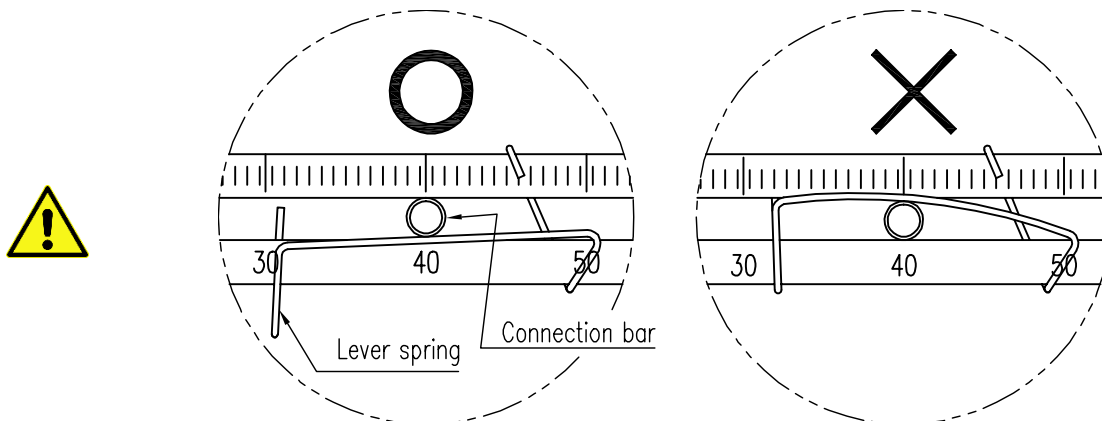

Fig. 3-7: Proper way to insert connection bar between feedback lever and lever spring

- 6) Check if feedback lever is vertical to the valve stem at 50 % of the valve stroke. If it is not vertical, adjust the bracket or the connection bar to make vertical. Improper installation may cause poor linearity.

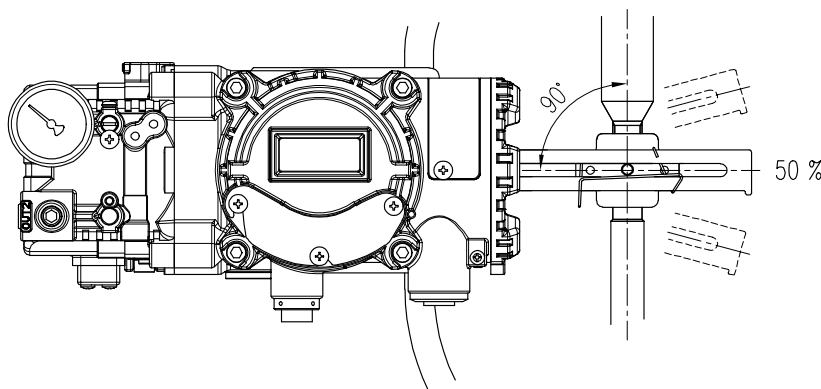

Fig. 3-8: Feedback lever and valve stem

- 7) Check the valve stroke. The stroke numbers are engraved on the feedback lever of the positioner. Position the connection bar at the number on the feedback lever which corresponds with the desired valve stroke. To adjust, move the bracket, the connection bar or both.

※ The effective linear lever angle is 30 degree.

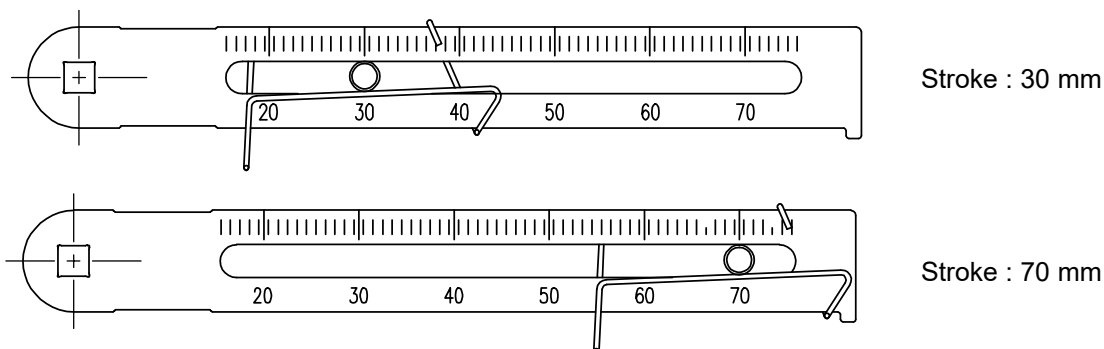

Fig. 3-9: Feedback lever and location of the connection bar



- 8) After installing the positioner, operate the valve from 0 % to 100 % stroke by using direct air to the actuator. On both 0 % and 100 %, the feedback lever should not touch the lever stopper, which is located on the backside of the positioner. If the feedback lever touches the stopper, the positioner should be installed further away from center of the actuator.

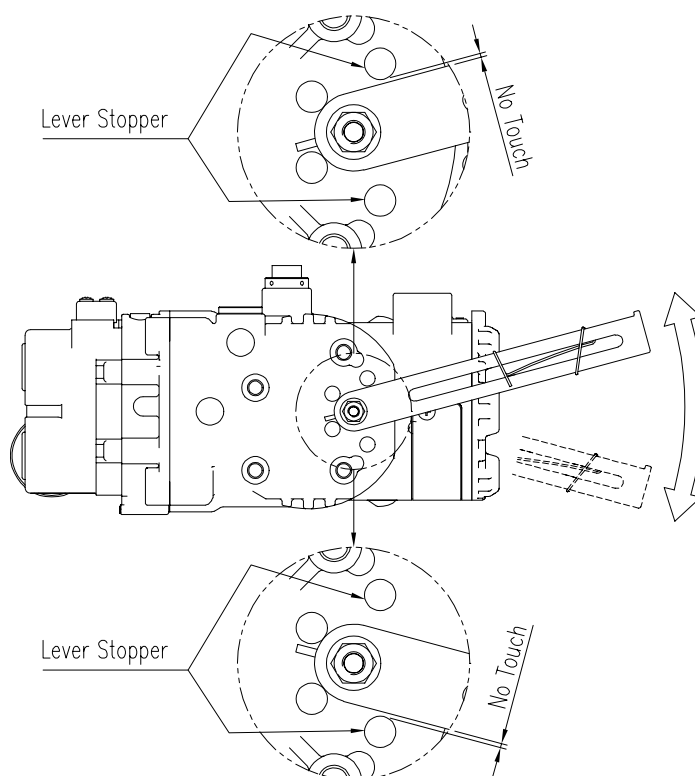

Fig. 3-10: Feedback lever should not touch lever stopper on 0 % ~ 100 % valve stroke.

- 9) After the installation, tighten all of the bolts on the bracket and the connection bar.

### 3.4 Rotary positioner Installation

Rotary positioner should be installed on rotary motion valve such as ball or butterfly type which uses rack and pinion, scotch yoke or other type of actuators which its stem rotates 90 degrees. Before proceeding with the installation, ensure following components are available.

#### 3.4.1 Components

- Positioner
- Fork lever (Only Fork lever type)
- Rotary bracket set (2 pieces)
- 4 pcs x hexagonal headed bolts (M8 x 1.25P)
- 4 pcs x M8 plate washers
- 4 pcs x wrench headed bolts (M6 x 1P x 15L)
- 4 pcs x M6 nuts
- 4 pcs x M6 spring washers
- Bolts and washers to attach bracket to actuator – not supplied with the positioner

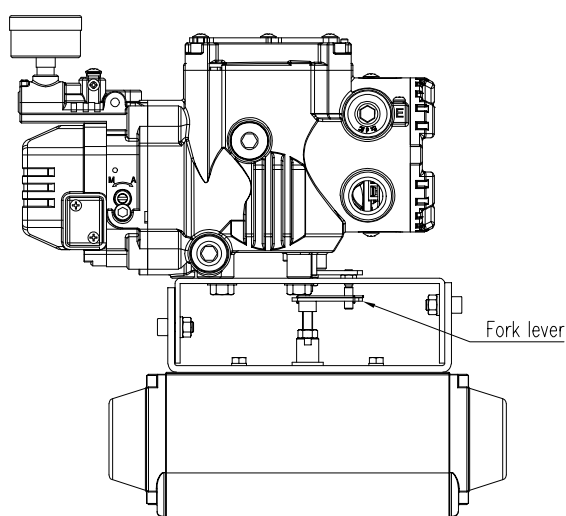

Fig. 3-11: Fork lever type

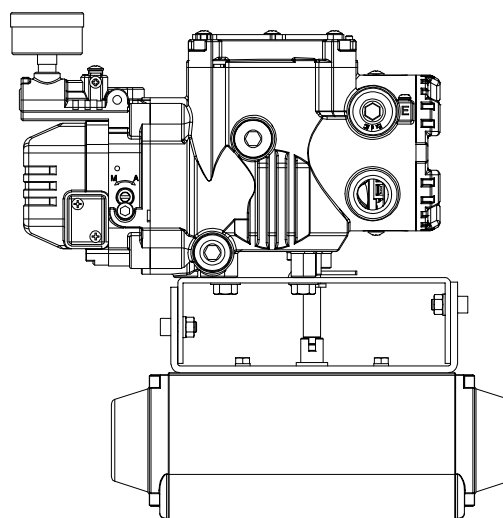

Fig. 3-12: Namur type

### 3.4.2 Rotary Bracket Information



The rotary bracket set (included with the positioner) contains two components. The bracket is designed to fit onto the actuator with 20 mm, 30 mm and 50 mm stem height (H) according to VDI/VDE 3845 standard. Please refer to below table how to adjust the height of the bracket.

Actuator stem height (H)	Markings of bolt holes			
	A-L	B-L	A-R	B-R
20 mm	H : 20	H : 20, 30	H : 20	H : 20, 30
30 mm	H : 30	H : 20, 30	H : 30	H : 20, 30
50 mm	H : 50	H : 50	H : 50	H : 50

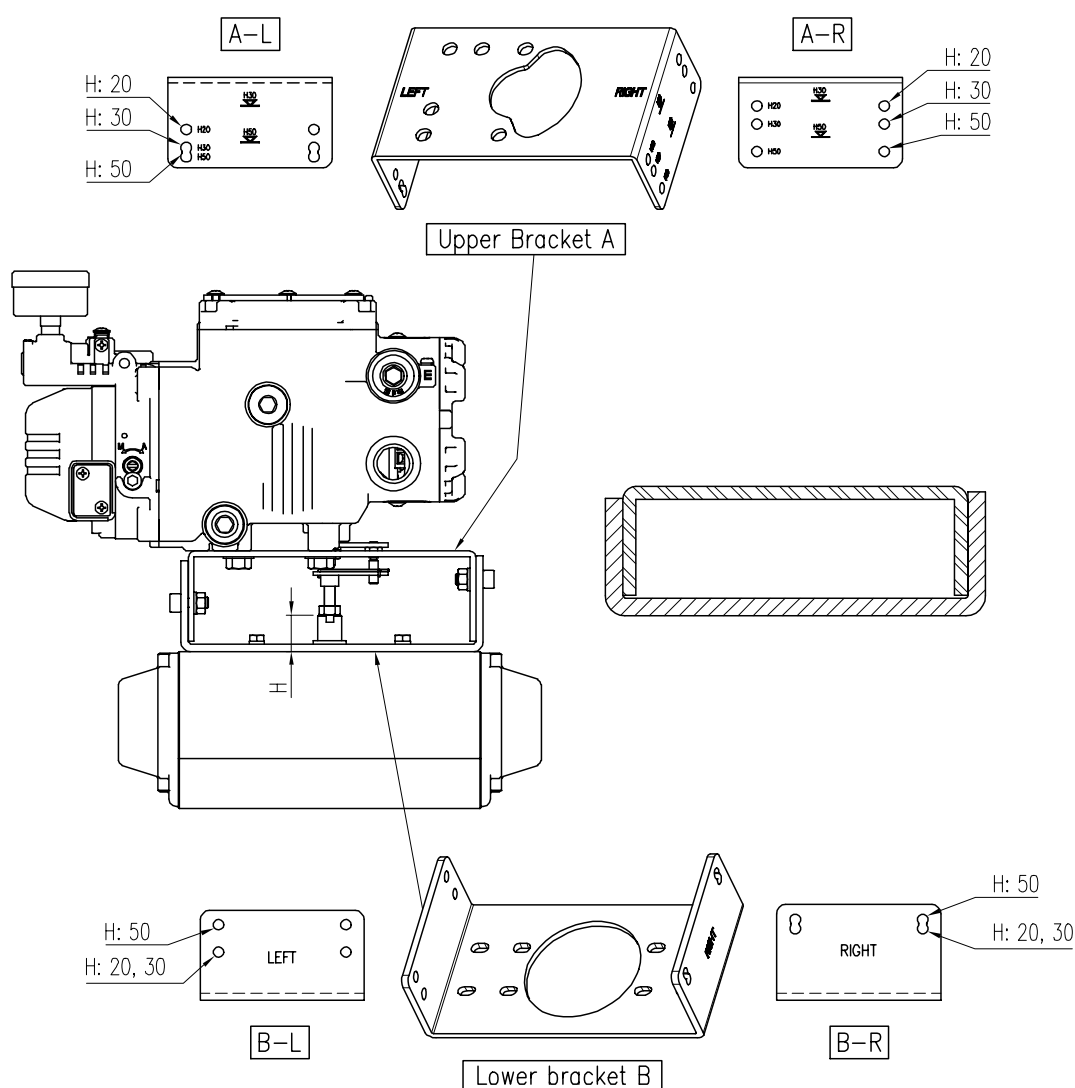

Fig. 3-13: Rotary Brackets and positioner

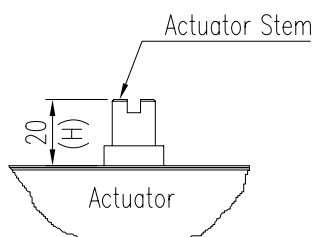

Fig. 3-14: Actuator stem Height

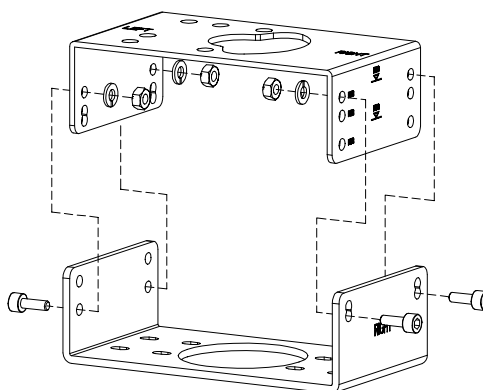

Fig. 3-15: Exploded Brackets

### 3.4.3 Rotary positioner Installation Steps

- 1) Please check the actuator's stem height and adjust the brackets by referring to the above bracket table.
- 2) Attached the brackets onto the actuator. It is recommended to use spring washer so the bolts will not be loosen from vibration.
- 3) Set rotation position of the actuator stem at 0 %. For single acting actuator, it is easy to check 0 % point by supplying no pressure to the actuator. For double acting actuator, check actuator stem's rotation direction – clockwise or counter-clockwise - by supplying pressure to the actuator.
- 4) (Only Fork lever type) Install the fork lever after setting actuator's stem at 0 %. Check the actuator stem's rotation direction – clockwise or counter-clockwise.  
Installation angle of the fork lever should be 45 ° to the longitudinal direction of the actuator.

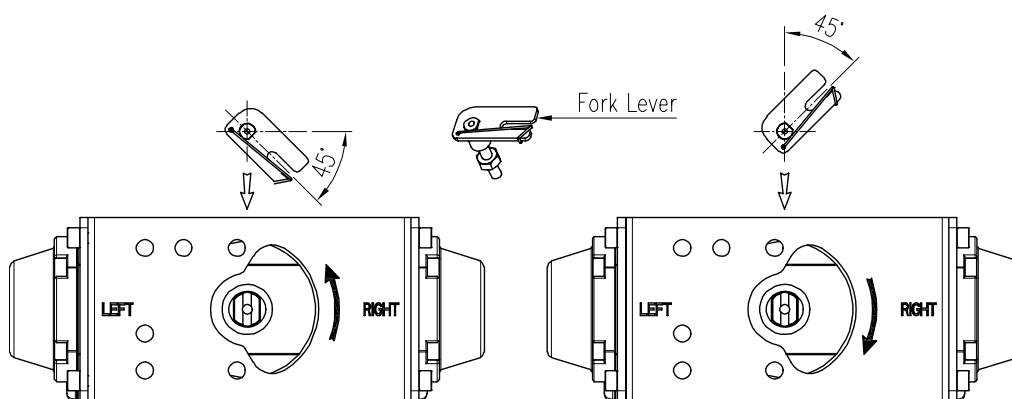

Fig. 3-16: Counter-clockwise and clockwise rotation.



- 5) (Only Fork lever type) After setting fork lever position, fasten lock nuts which are located on the bottom of the fork lever. Ensure to set the gap between the top of upper bracket and the top of the fork lever within **6 ~ 11 mm**.

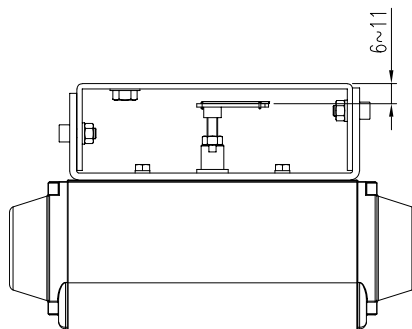

Fig. 3-17: Height to the bracket (fork lever type)



- 6) Attach the positioner to the bracket. *<Only fork lever type: Fix the clamping pin (5 mm Dia.) into the fork lever slot and insert center pin (2 mm Dia.) of the main shaft of the positioner into the hole of center of the fork lever. The clamping pin will be locked to the fork lever spring.>* Setting alignment of center of main shaft of the positioner and center of the actuator's stem is very important. Poor alignment of the main shaft and the actuator's stem decreases the positioner's durability due to unnecessary forces on the main shaft.

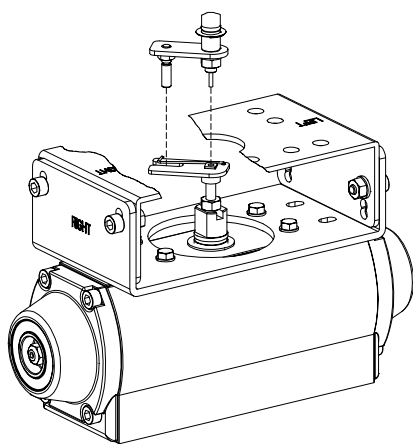

Fig. 3-18: Main shaft center alignment (Fork lever)

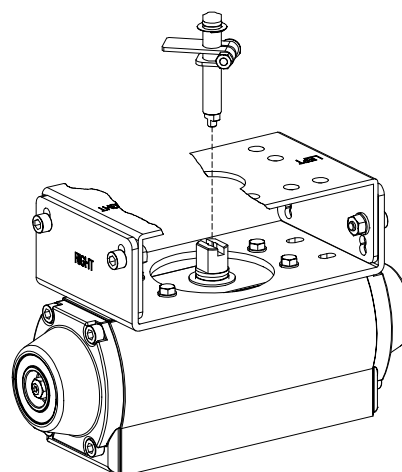

Fig. 3-19: Main shaft center alignment (Namur)

- 7) Tighten the positioner and the bracket with bolts **after checking the positioner's position**.

## 4 Connection - Air

### 4.1 Safety

- Supply pressure should be clean and dry air – avoiding moisture, oil and dust.
- Always recommended to use air filter regulator (i.e. YT-200 series).
- Tapped Exhaust (AG option) is used when it is required to vent away the Group D gases to a safe area. Tapped Exhaust for use in FM & CSA Division approved hazardous locations must be sealed to prevent leaks at the 1/4" NPT connection for use with Division Group D gases such as natural gas or methane as the process medium.
- Group D gases as Process Medium - Maximum supply pressure must not exceed 101 PSIG (7 BAR)
- Group D gases as Process Medium - The gas must be compatible with the wetted parts of the positioner.
- A conduit seal is required within 50 mm of the enclosure to prevent the passage of a process medium gas from migrating into the conduit system to a possible ignition source.

### 4.2 Supply Pressure Condition



- Dry air with dew point of at least 10 °C lower than ambient temperature.
- Avoid from dusty air. Use 5 micron or smaller filter.
- Avoid oil.
- Comply with ISO 8573-1 or ISA 7.0.01.
- Supply pressure range is 0.14 ~0.7 MPa (1.4 ~ 7 bar)
- Set air filter regulator's pressure level 10 % higher than actuator's spring range pressure.

### 4.3 Piping Condition



- Ensure inside of pipe is clean of obstructions.
- Do not use pipeline that is squeezed or shows any type of damages.
- Pipeline should have more than 6mm of inner diameter (10 mm outer diameter) to maintain flow rate.
- The length of pipeline system should not be extremely long. Longer pipeline system may affect flow rate due to the friction inside of the pipeline.



4.4 Connection – Piping with actuator

4.4.1 Single acting actuator

Single acting type positioner is set to use only OUT1 port. OUT1 port of positioner should be connected to supply port of actuator when using spring return actuator of single acting type.

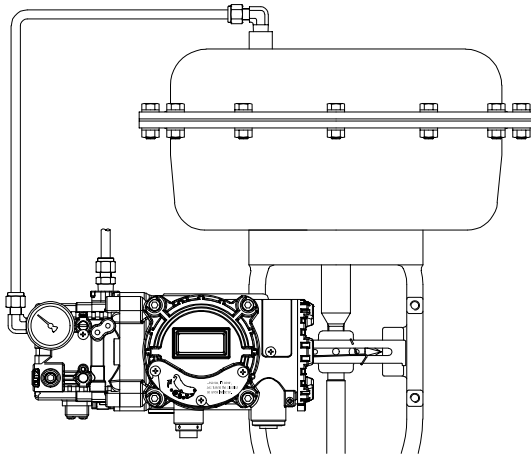

Fig. 4-1: Single acting linear actuator

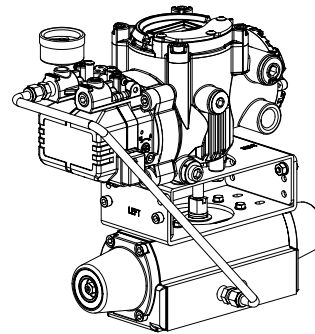

Fig. 4-2: Single acting rotary actuator

4.4.2 Double acting actuator

Double acting type positioner is set to use OUT1 and OUT2 port. As input signal increases, the supply pressure will be supplied through OUT1 port.

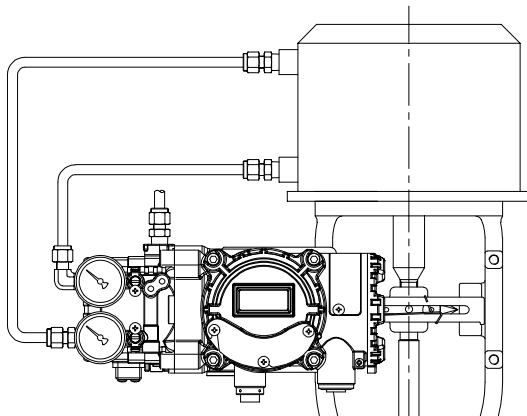

Fig. 4-3: Double acting linear actuator

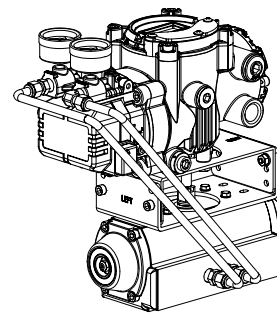

Fig. 4-4: Double acting rotary actuator

## 5 Connection – Power

### 5.1 Safety



- There are two conduit entries on the product. See “2.4 Product Code” for conduit entry threads.
- Installer must use wire type that has a temperature rating  $\geq 105$  °C.
- Overvoltage category: II (in accordance with IEC60664-1).
- When installing in hazardous and explosive gas area, conduit tube or pressure-proof packing union must be used. The compound charging box should be the flameproof type and must be sealed completely.
- Before connecting terminal, ensure that the power is off completely. **Do not open the cover when the power is still alive.**
- Please use ring terminal to protect against vibration or any other external impact.
- Positioner usually uses 4 ~ 20 mA DC. Minimum ampere of input signal of standard type positioner is 3.6 mA, PTM internal type is 3.7 mA and HART or HART+PTM internal type is 3.8 mA but maximum ampere of input signal should be 24 mA or under.
- Compliance voltage of current source must be Min. 10 V and Max. 28 V. If the length of the supply cable between the current source and the positioner is long, or if there is a filter or safety barrier, then consider using a current source which could supply higher Compliance voltage.
- Positioner with PTM options must be supplied with **9 ~ 28 V DC** separately. For L/S option (transistor type), separate **24 V DC (50 mA)** must be supplied.
- **DO NOT connect Voltage source (9 ~ 28 V DC) to Input (4 ~ 20 mA DC) terminal (IN+, IN-) as it will cause PCB failure.**
- Positioner should be grounded.
- Please use twisted cable with conductor section are 1.25 mm<sup>2</sup> and that is suitable for 600 V (complying with the conductor table of NEC Article 310). The outer diameter of the cable should be between 6.35 ~ 10 mm. Use shield wire to protect against electro-magnetic field and noise.
- Please do not install the cable near high noise equipment, such as high-capacity transformer or motor.
- Please ensure that keep magnetic materials away from a product. It may cause malfunction. For a magnetic screwdriver, it must be away more than 30cm from the positioner.

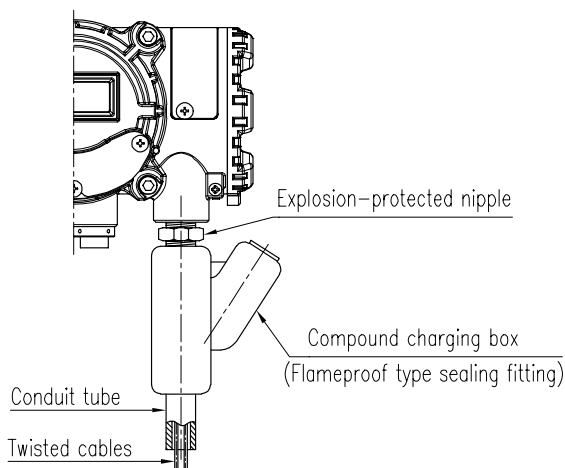
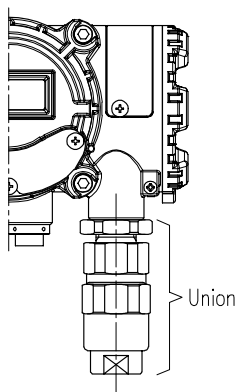

Fig. 5-1: Pressure-proof packing union      Fig. 5-2: Flame proof type compound charge box

## 5.2 Terminal overview

- 1) Open terminal cover by loosening a locking socket set screw using 2 mm hex wrench.
- 2) Insert signal cables with ring terminals into the conduit entry and secure them on the terminals of the block by tightening bolts with 1.5 N · m (15 kgf · cm) torque. Please check the polarity of the terminals.
- 3) Close the terminal cover and fasten the locking socket set screw.

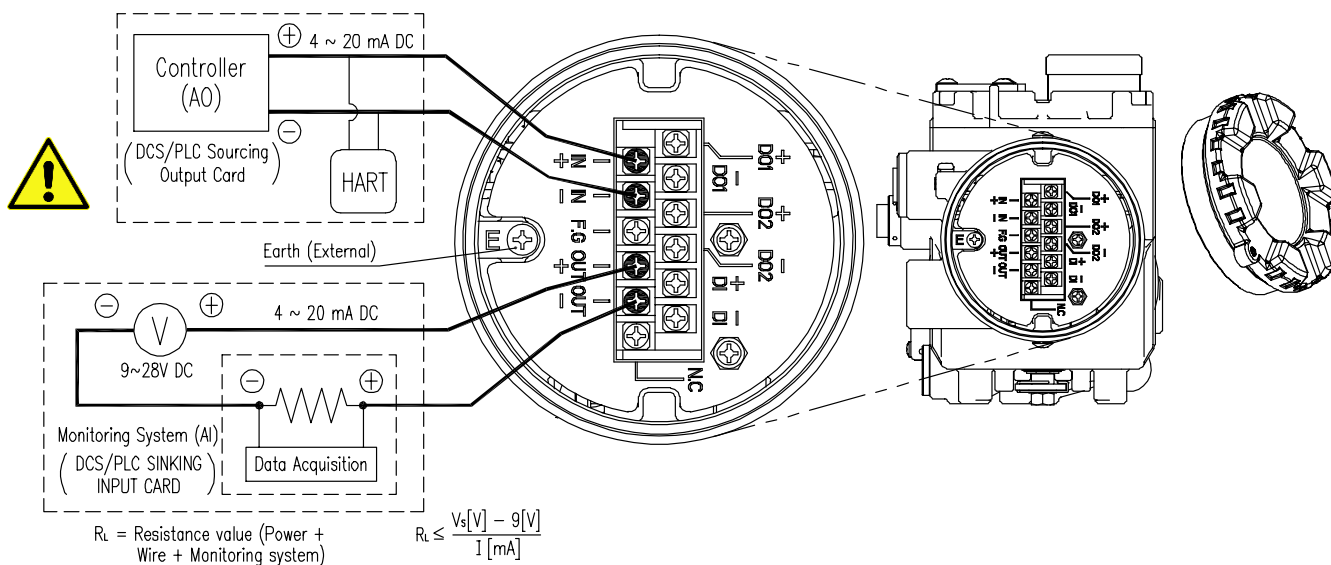

Fig. 5-3: Terminal Overview 1 (IN, OUT)

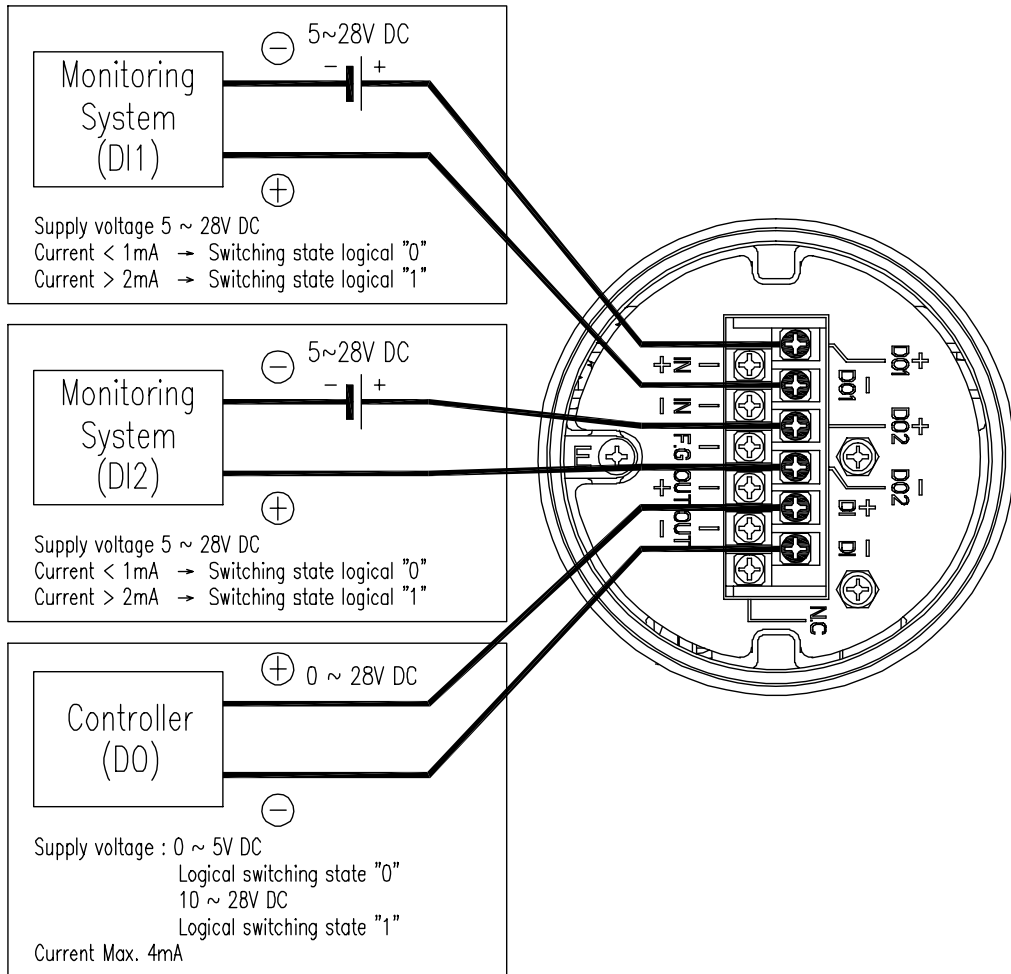

Fig. 5-4: Terminal Overview 2 (DO1, DO2, DI)

Terminal name	Signal name	Function
IN +, IN –	Current input signal (+), (–)	Apply analog current command 4 ~ 20mA to this terminal to supply power and signal to the positioner.
F.G	Safety ground	Safety ground
OUT +, OUT –	Analog output signal (+), (–)	Analog feedback signal indicating the position of the current valve (4 ~ 20 mA)
DO1 +, DO1 –	Digital output signal1 (+), (–)	A digital output signal that is activated when a specific event or alarm is triggered. It can also be used as a limit switch. When the output is activated by Low logic at the input voltage range of 5 ~ 28V, no current flows to the output port, and when it is activated by High logic, the current flows between 2.2 and 14 mA. (Refer to “8.10.7 Digital Output Logic”)
DO2 +, DO2 –	Digital output signal2 (+), (–)	If you want to use it as a limit switch function, set the limit switch mode to ON and use it. (Refer to “8.10.5 Limit Switch Mode”) Set the TVLHI or TVLLO value to determine the valve position operated by the limit switch. The initial values are 100% and 0%, respectively. (Refer to “8.12.5 Diagnostic Limit Configuration”)
DI +, DI –	Digital input signal (+), (–)	A digital input that performs a specific function. The 0 ~ 5 V input is defined as Low level, and the 10 ~ 28 V input is defined as High level. (Refer to “8.9.11 Digital Input Function and 8.9.12 Digital Input Logic”)

5.2.1 Ground

- 1) Ground must be done before operating the positioner.
- 2) There are three ground bolts at the positioner. Open terminal cover and there are two internal ground bolts on the left inside of housing and on the left of terminal plate. When using internal ground, use 2 mm hex wrench to loosen a socket set screw of of the terminal box cover. An external ground bolt is located next to the conduit entry. Please make sure that the resistance is less than 100 ohm.
- 3) When using external ground, use (+) screw driver to unscrew the ground bolts. Insert external ground bolts and spring washer into ring type terminal of the ground cables and tighten them with bolts.

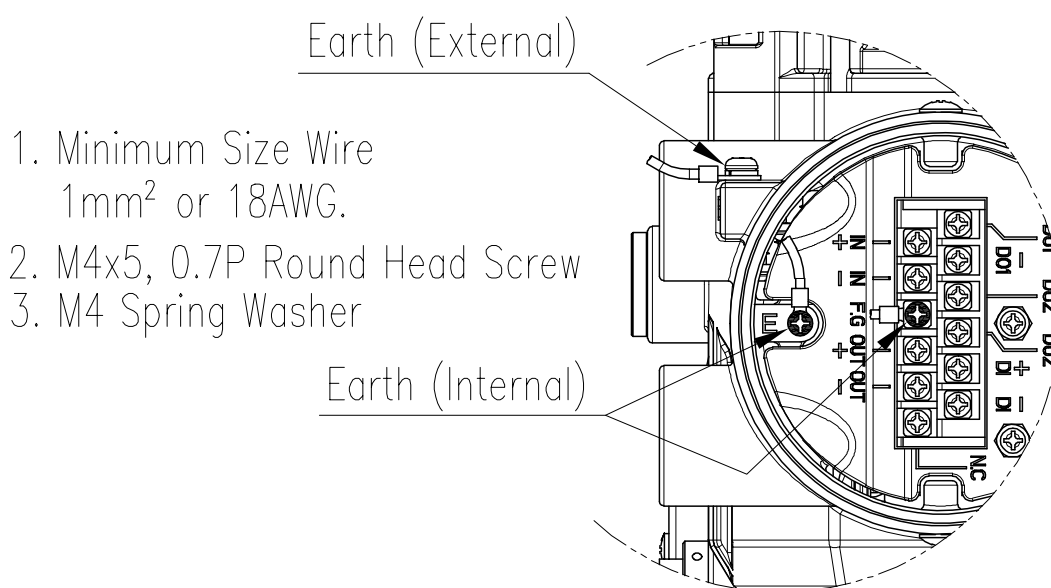

Fig. 5-5: Connecting Earth

## 6 Adjustments

### 6.1 A/M switch adjustment

- 1) On the left hand bottom of positioner, there is A/M switch (Auto/Manual). If the switch is turned clockwise (toward “A”) and fastened tightly, then the supply pressure will be transferred to actuator through outport by positioner control. On the other hand, if the switch is turned counterclockwise (toward “M”) and loosened, then the supply pressure will be directly supplied to the actuator regardless of positioner control.
- 2) Make sure that the pressure level of the air supply is lower than the pressure rating of the actuator before the switch is loosened.
- 3) After using “Manual” function, A/M switch should be returned to “Auto”.

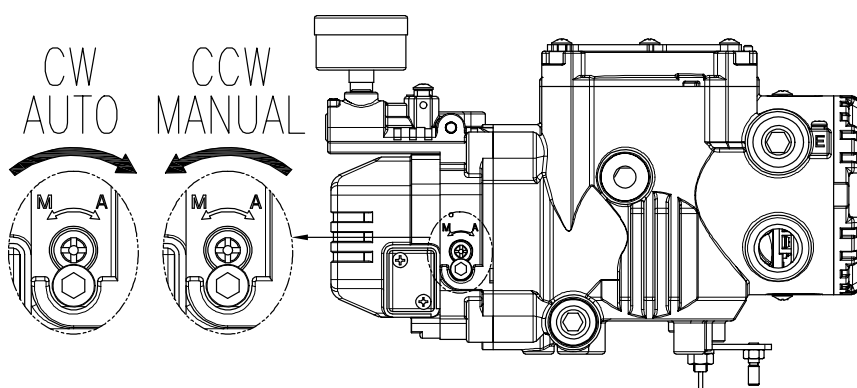

Fig. 6-1: A/M switch adjustment

### 6.2 Variable Orifice Adjustment

Hunting can be occurred when the actuator’s volume is too small. In order to prevent hunting, orifice can be adjusted. By adjusting the orifice, the flow rate of the supply pressure to actuator can be adjusted. Please use (-) driver to adjust the orifice. When slot (-) of the orifice is horizontal, the flow rate becomes maximum. When slot (-) of the orifice is vertical, the flow rate becomes minimum.

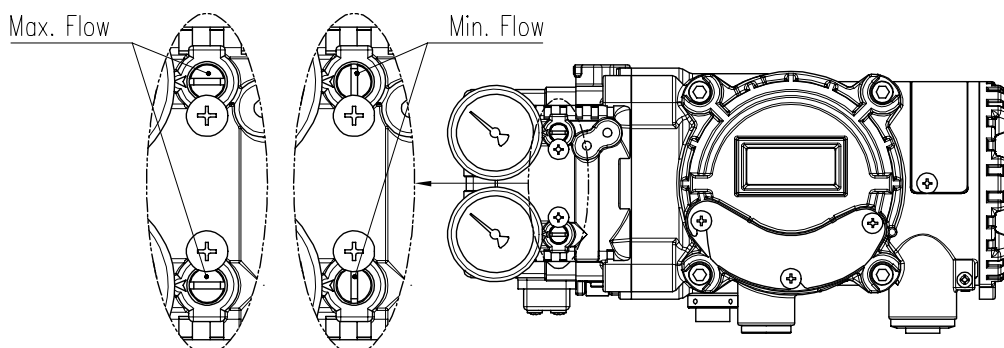

Fig. 6-2: Variable orifice adjustment

## **7 Maintenance**

### **7.1 Supply air**

If Supply air pressure is not stable or Supply air is not clean, the positioner may not function properly. Air quality and pressure should be checked regularly to see if the air is clean and pressure set is normal.

### **7.2 Seals**

it is recommended to check if there are any damaged parts of the positioner once a year. If there are damaged rubber parts such as diaphragms, o-rings and packings, replace with new ones.



## 8 Auto Calibration and PCB Operation

### 8.1 Warning



Following process will operate valve and actuator. Before proceeding with any Auto Calibration, please separate valve from the entire system by using bypass valve, so Auto Calibration will not affect entire valve process.

### 8.2 LCD display and buttons

#### 8.2.1 LCD display and symbols

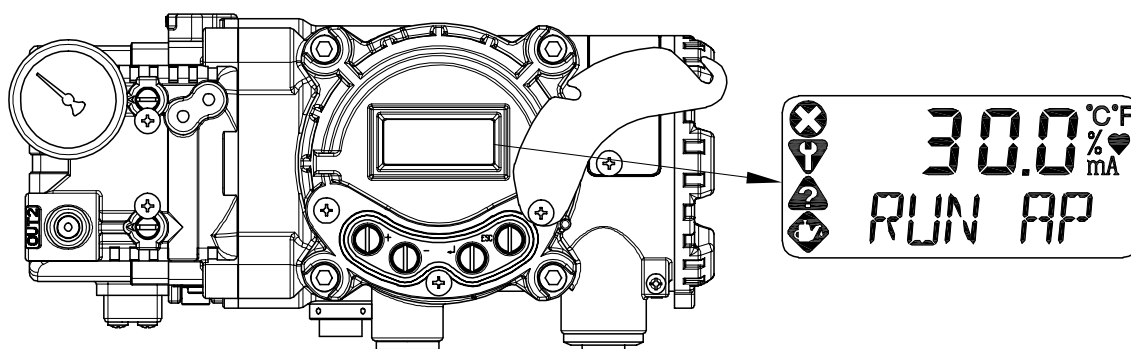

Fig 8-1

NE107 Symbols	Description	Symbols	Description
	Failure	°C	Degree in Celsius
	Functional Check	°F	Degree in Fahrenheit
	Out of Specifications	%	Percent
	Maintenance Required	mA	Current in mA

The four symbols located on the left are the symbols that display alarm messages classified in four groups in accordance with NAMUR NE107. Assigning each alarm to a specific group of four groups can only be performed through EDD or DTM.

8.2.2 Button and function

Positioner has 4 buttons that perform various functions.

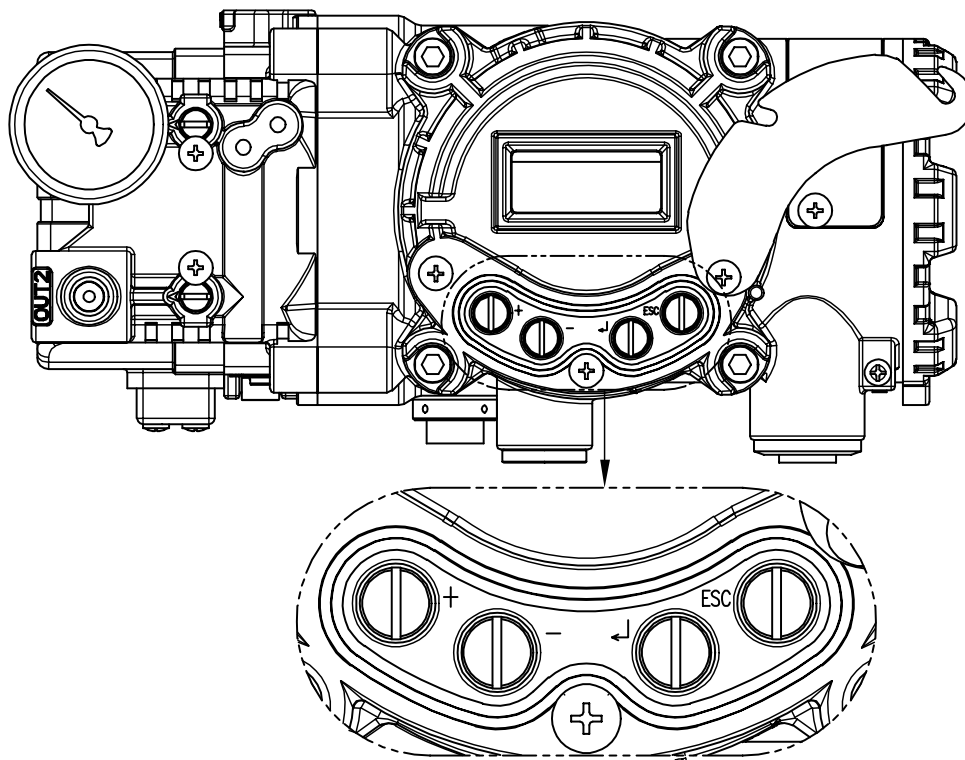
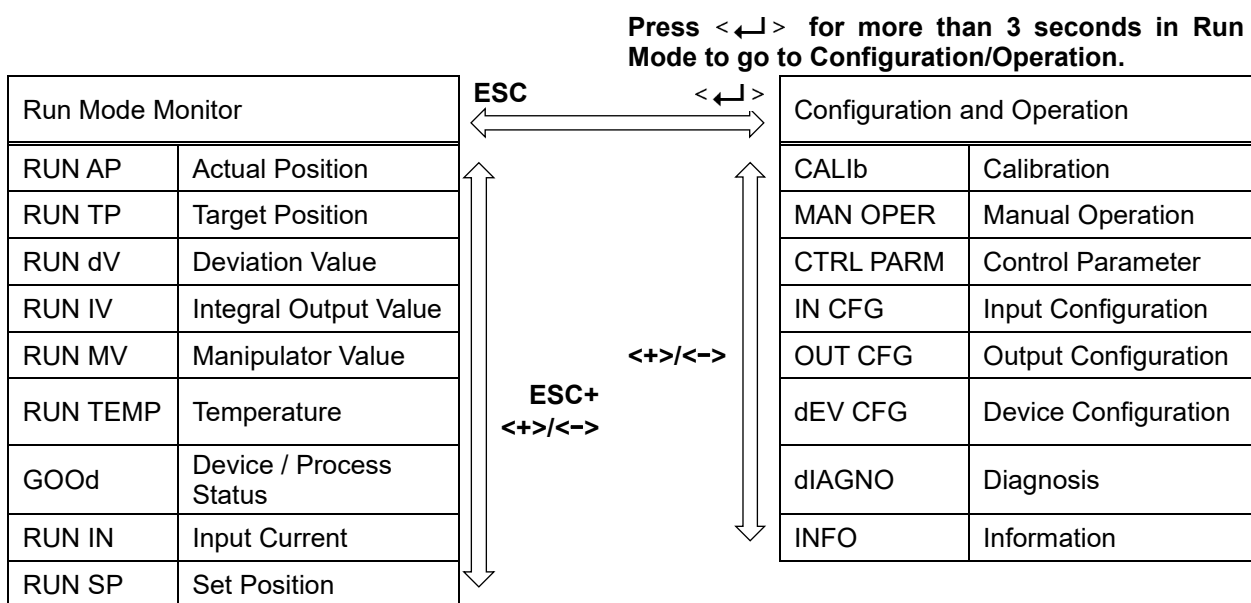

Fig 8-2

Buttons	Function
+	Used to navigate to each menu at the same level or to increase the value of the selected parameter.
— (DOWN, DN)	Used to navigate to each menu at the same level in reverse order of <+> button or to decrease the value of the selected parameter.
<↵> (ENTER)	Use to select the current menu or function, or to store the value of a modified parameter.
ESC	Used go directly to parent menu from current menu.

### 8.3 Menu levels

The basic menu structure consists of the RUN Mode Monitor and the Configuration/Operation. The Run Mode Monitor menu allows you to monitor the values of various variables. The Configuration/Operation menu provides calibration and tuning, manual operation, configuration of I/O port function, configuration and self-test of positioner, configuration of diagnostic function, and basic information of the positioner. See below for information on how to move between Run Mode Monitor menu and Configuration/Operation menu and how to move within Run Mode Monitor menu or Configuration and Operation.



Press the <↵> button to select the lower menu of the Configuration/Operation menu. Press the ESC button to return to parent menu after completing configuration. Pressing the ESC button anywhere in the menu structure several times returns the user to the uppermost menu, Run Mode Monitor menu.

8.4 Run Mode (RUN)

The RUN Mode Monitor is displayed on the LCD display when power is provided to the positioner. Pressing the UP/DOWN button scrolls through the various process variables shown in table below. A "30.0 %" in the LCD display on the right indicates that the valve is in the 30 % position, and an "AP" indicates the abbreviation of "Actual Position".

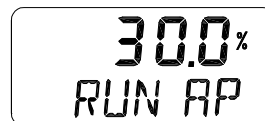

The status variables displayed in the RUN Mode Monitor are divided into nine types as shown below.

On LCD	Name	Description
RUN AP [%]	Actual Position	Actual position of the valve indicated as %.
RUN TP [%]	Target Position	Target position in %
RUN dV [%]	Deviation Value	Deviation between target position and actual position.
RUN IV	Integral Output Value	Accumulated integral output value
RUN MV	Manipulator Value	Digital input value applied to I/P converter
RUN TEMP[°C]	Temperature	Internal temperature of positioner in °C.
** dS XXXX (PS XXXX)	**: Alarm Code  dS: Device Status PS: Process Status  XXXX: NE107 or Abbreviation of each alarm	The status of the current process or positioner is shown with English letter XXXX. Normally, GOOD is displayed when there is no problem, but alarm or status is displayed in abbreviated words (MNTR, FAIL, OUTS, FUNC and so on) along with NE107 symbol when a state change or alarm occurs. Any of the alarms is displayed alternately each time the ENTER button is pressed. (See 8.15 Status and Alarm Code)
RUN IN [mA]	Input Current	Current input signal in mA
RUN SP [%]	Set Position	Input signal converted into %

# When there is no alarm.



# When an alarm occurs.

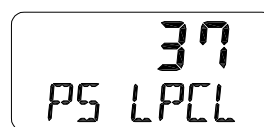

# Explaining contents of alarm display

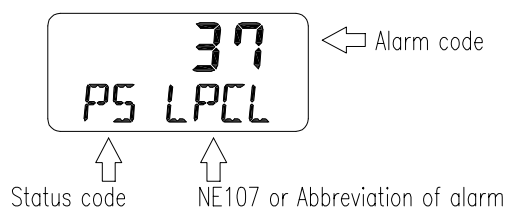

8.5 Configuration and Operation

The Table below shows the eight Configuration/Operation menus, each submenu, ranges for each parameter, and initial factory settings. The words shown in [ ] for each menu represent the abbreviations of each word displayed when operating the LCD screen.

Level 1	Level 2	Range	Initial factory setting
Calibration [CALIb]	Acting Type	[SINGLE, dOUbLE]	
	Auto Calibration 1 [AUTO 1]		
	Auto Calibration 2 [AUTO 2]		
	Travel Zero [TVL ZERO]		
	Travel End [TVL ENd]		
Manual Operation [MAN OPER]	Manual Operation by Set Position [MAN SP]		
	Manual Operation by Manipulator Value [MAN MV]		
Control Parameters [CTL PARM]	Dead Band [dEAdbANd]	0.1 ~ 10.0 [%]	0.3 %
	Proportional Gain, Upward [KP UP]	0.1 ~ 50.0	1
	Proportional Gain, Downward [KP dN]	0.1 ~ 50.0	1
	Integral Gain, Upward [TI UP]	0.1 ~ 50.0	1
	Integral Gain, Downward [TI dN]	0.1 ~ 50.0	1
	Differential Gain, Upward [Kd UP]	0.1 ~ 50.0	1
	Differential Gain, Downward [Kd dN]	0.1 ~ 50.0	1
	Gap [GAP]	0.1 ~ 5.0 [%]	1 %
	GP [GP]	0.1 ~ 5.0	1
	GI [GI]	0.1 ~ 5.0	1
	GD [Gd]	0.1 ~ 5.0	1
	Auto Dead Band Mode [AUTO db]	oFF, [0%]	oFF
	Performance Mode [PER]	Stable, Normal, Fast [STbL, NORM, FAST]	NORM
Input Configuration [IN CFG]	Signal Direction [SIG]	Normal, Reverse [NORM, REVS]	NORM
	Split Range Mode [SPLIT]	4 ~ 20, 4 ~ 12, 12 ~ 20, Custom [4.20, 4.12, 12.20, CSSt]	4.20
	Custom Split Range Zero [CST ZERO]	4 ~ 20.0 mA]	4 mA
	Custom Split Range End [CST ENd]	4 ~ 20.0 [mA]	20 mA

Level 1	Level 2	Range	Initial factory setting
Input Configuration [IN CFG]	Characterization [CHAR]	Linear, Quick Open, Equal Percent, User Set 5point, User Set 21point [LIN, QO, EQ, U5, U21]	LIN
	User Set Characterization 5p [USER 5P]	0 ~ 110 [%]	0 %, 25 %, 50 %, 75 %, 100 %
	User Set Characterization 21p [USER 21P]	0 ~ 110 [%]	0 %, 5 %, 10 %, ... 95 %, 100 %
	Tight Shut Open [TSHUT OP]	0 ~ 100 [%]	100.0 %
	Tight Shut Close [TSHUT CL]	0 ~ 100 [%]	0.3 %
	SP Ramp Up Rate [RAMP UP]	oFF, 0.1 ~ 100 [%]	oFF
	SP Ramp Down Rate [RAMP dN]	oFF, 0.1 ~ 100 [%]	oFF
	Digital Input Function [dIF]	[oFF, FCL, FOP, PSTA, PSTO]	oFF
	Digital Input Logic [dI LOGIC]	[Lo, HI]	HI
Output Configuration [OUT CFG]	Position Transmitter Direction [PTM]	[NORM, REVS]	NORM
	Position Transmitter Zero [PTM ZERO]	0 ~ 100.00 [%]	
	Position Transmitter End [PTM ENd]	0 ~ 100.00 [%]	
	HART Feedback Direction [HT]	[NORM, REVS]	NORM
	Back Calculation [bACKCAL]	[oFF, on]	oFF
	Limit Switch [LS Mode]	[oFF, on]	oFF
	Digital Output 1 Function [dO1]	[OFF, TMPH, TMPL, TVLH, TVLL, dVTO, PSTF, LPCL, FAIL, FUNC, OUTS, MNTR]	oFF
	Digital Output 1 Logic [dO1 LOGIC]	[Lo, HI]	HI
	Digital Output 2 Function [dO2]	[OFF, TMPH, TMPL, TVLH, TVLL, dVTO, PSTF, LPCL, FAIL, FUNC, OUTS, MNTR]	oFF
	Digital Output 2 Logic [dO2 LOGIC]	[Lo, HI]	HI
Device Configuration [dEV CFG]	Analog Output Function [AOF]	[OFF, TMPH, TMPL, TVLH, TVLL, DVTO, PSTF, LPCL, FAIL, FUNC, OUTS, MNTR]	OFF
	AO Current for Alarm Function [AO LOGIC]	[Lo, HI]	LO
	Action [ACT]	[dIR, REVS]	REVS
	Linear Lever Type [LEVT]	[STd, AdP]	STd
	Linear Interpolation [ITP]	[oFF, on]	on with Linear oFF with Rotary

Level 1	Level 2	Range	Initial factory setting
Device Configuration [dEV CFG]	Write Protect [W]	[UNLOCK, LOCK]	UNLOCK
	View Mode [VI]	[NORM, REVS]	NORM
	Polling Address [POL Addr]	[0 ~ 63]	0
	Factory Reset [dEFAULT]		
	Self-Test [SELFTEST]		
Diagnosis [dIAGNO]	Process Status [PS]	GOOd, FAIL, FUNC, OUTS, MNTR	GOOd
	Device Status [dS]	GOOd, Refer to 8.15 Status and Alarm Code.	GOOd
	View Monitoring Counts [VI CNTS]	[CYCL CNT, TVL ACUM, OPER CNT, FOP CNT, FCL CNT]	0
	Diagnosis Limit Configuration [LIMIT CFG]	TVL HI, TVL LO, TEMP HI, TEMP LO, dV TIME, dV db, AL TVLH, AL TVLL, AL TMPH, AL TMPL, AL dVTO	100 %, 0 %, 85 °C -30 °C (depending on option) 10 sec, 5.0 %, oFF, oFF, oFF, oFF, on
	Reset Alarm Status [RST ALRM]		
	View Event Log [EVT LOG]	RECORD 0 - 19	0
	View PST Result Record [PST RSLT]	RECORD 1 - 10	bLANK
	PST Configuration [PST CFG]	INTERVAL, START PO, TOL, TARGET, HOLD TM, LIMIT TM, PRAMP UP, PRAMP dN, NEXT PST	365 d, 100 %, 5 %, 90 %, 5 sec, 10 sec, 0 %, 0 %, oFF
	Run PST [PST NOW]		
	PST Schedule [PST SChd]	on, oFF	oFF
Information [INFO]	Model Name [YT3400*]		
	Firmware Version [SOFT VER] Download Date	*.*.* YYYYMMDD	Program current version Program input date
	Run Time [RT]	*.*.* RT *d	
	Upward Stroke Time [FULL OP]	*.*.*	
	Downward Stroke Time [FULL CL]	*.*.*	

Level 1	Level 2	Range	Initial factory setting
Information [INFO]	Position Sensor Type [PSNT]	PTN, NCS	
	Absolute Position in Angle [AbS ANGL]	*** * °	
	HART Protocol Revision [HART VER]	7	7

The Table below identifies the range and initial factory settings of each parameter for Menu Level 2 and Menu Level 3 where the menu hierarchy has been lowered by one level.

Level 2	Level 3	Range	Initial factory setting
View Monitoring Counts [VI CNTS]	Cycle Count [CYCL CNT]	0 ~ 4,200,000,000	
	Travel Accumulated [TVL ACUM]	0 ~ 168,000,000 [%]	
	Operating Count [OPER CNT]	0 ~ 4,200,000,000	
	Full Open Count [FOP CNT]	0 ~ 4,200,000,000	
	Full Close Count [FCL CNT]	0 ~ 4,200,000,000	
LIMIT CFG	Travel Hi Limit [TVL HI]	0 ~ 120 [%]	100 %
	Travel Lo Limit [TVL LO]	-10 ~ 50 [%]	0 %
	Temperature Hi Limit [TEMP HI]	-57 ~ 85 [°C]	Selecting by temp. option
	Temperature Lo Limit [TEMP LO]	-57 ~ 85 [°C]	Selecting by temp. option
	Deviation Time [dV TIME]	0 ~ 300 [sec]	60 sec
	Deviation Deadband [dV db]	0 ~ 10 [%]	5 %
	Travel Hi Limit Alarm Enable [AL TVLH]	oFF, on	oFF
	Travel Lo Limit Alarm Enable [AL TVLL]	oFF, on	oFF
	Temperature Hi Limit Alarm Enable [AL TMPH]	oFF, on	oFF
	Temperature Lo Limit Alarm Enable [AL TMPL]	oFF, on	oFF
Deviation Time Out Alarm Enable [AL dVTO]	oFF, on	oFF	
PST CFG	PST Interval [INTERVAL]	1 ~ 365 [days]	365
	PST Starting Position [START PO]	0 ~ 100 [%]	100 %
	PST Tolerance [TOL]	0.1 ~ 10 [%]	5 %
	PST Target Position [TARGET]	0 ~ 100 [%]	90 %
	PST Hold Time [HOLD TM]	1 ~ 60 [sec]	5 sec
	PST Limit Time [LIMIT TM]	1 ~ 300 [sec]	10 sec



Level 2	Level 3	Range	Initial factory setting
PST CFG	PST Ramp Up Rate [PRAMP UP]	oFF, 1 ~ 100 [%/sec]	oFF
	PST Ramp Down Rate [PRAMP dN]	oFF, 1 ~ 100 [%/sec]	oFF
	PST Time Remaining [NEXT PST]	oFF, 1 ~ 365 [days], 0 ~ 24 [hour]	oFF

8.6 Calibration (CALib)

The calibration consists of five menus.

Calibration [CALib]	Acting Type [SINGLE/ dOUBLE]	Set manually single or double acting by actuator type
	Auto Calibration 1 [AUTO 1]	Calibration on the zero and end points of the valve
	Auto Calibration 2 [AUTO 2]	Calibration on all parameters required to operate the valve
	Travel Zero [TVL ZERO]	Manually adjust the zero point of the valve
	Travel End [TVL ENd]	Manually adjust the endpoint of the valve

Auto Calibration simplifies calibration without having to go through complex gain tuning. Once the current input between 4 and 20 mA is applied, it takes approximately 2-3 minutes to complete the automatic calibration, which may vary depending on the size of the actuator. There are two types of Auto Calibrations as shown below so that you select and use them as required.

	ZERO	END	P, I, D gain	RA, DA	BIAS
AUTO 1	O	O	X	X	X
AUTO 2	O	O	O	O	O

8.6.1 Acting Type (SINGLE / dDOUBLE)

This is used to change the settings of the positioner to SINGLE or dDOUBLE, depending on the actuator type. The setting of the SINGLE and dDOUBLE affects the automatic calibration, so it must be set carefully considering the actuator type.



**If the actual acting type of Actuator is different from the set value, it will cause a problem, so make sure that the actual acting type matches the set value.**

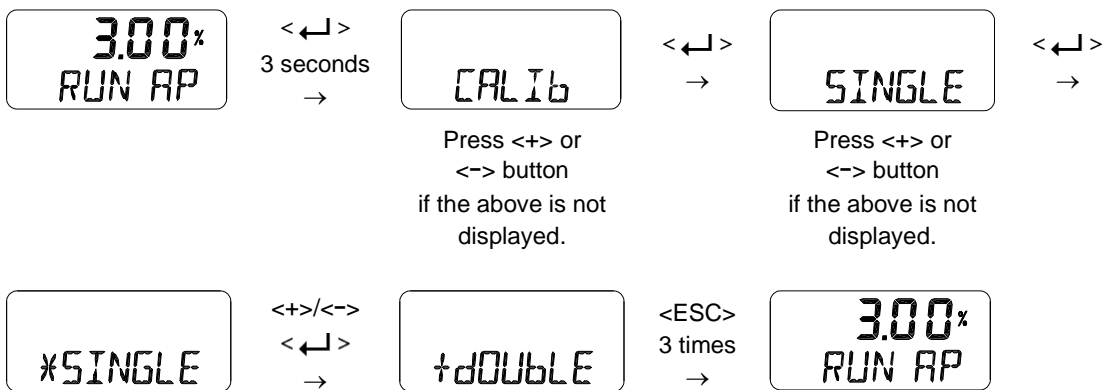

8.6.2 Auto Calibration 1 (AUTO 1)

AUTO 1 is used to set only the origin and end points. It does not change the PID and other parameter values that already have been set. This is usually used when the origin and end points of the already calibrated positioner have changed slightly.

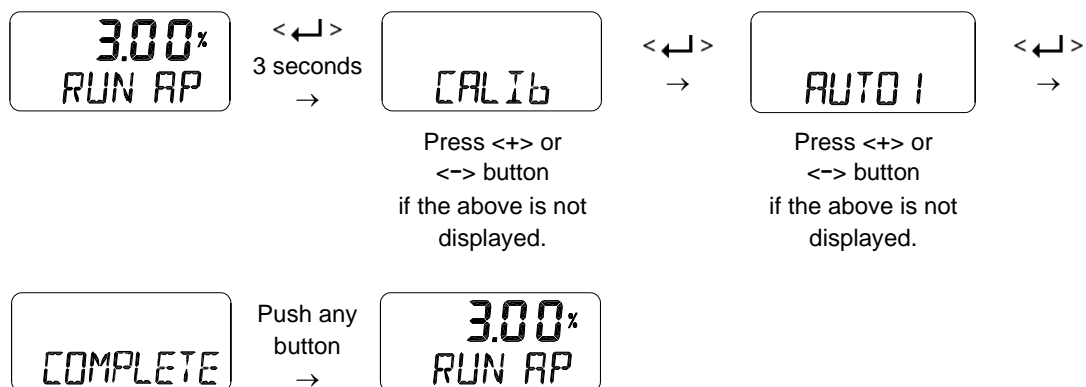

8.6.3 Auto Calibration 2 (AUTO 2)

AUTO 2 tunes up and then changes all parameters required for valve operation. Be sure to perform this AUTO 2 when installing the positioner on the valve for the first time or when reinstalling the positioner from the actuator.

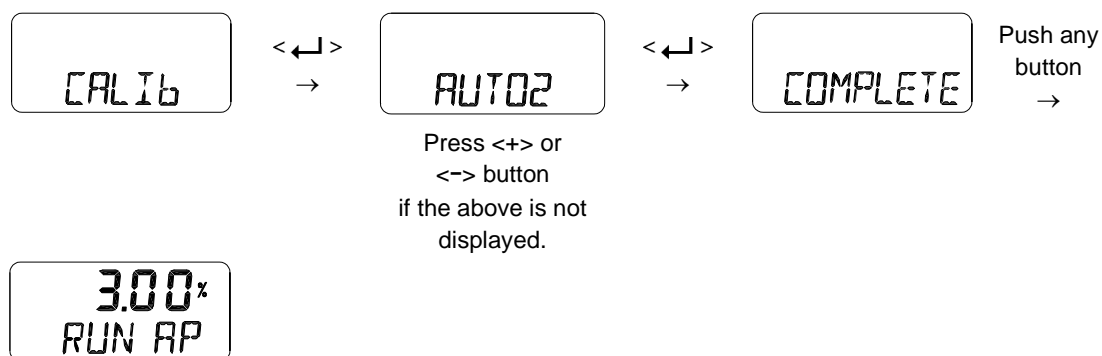

8.6.4 Travel Zero (TVL ZERO) and Travel end (TVL ENd)

This is a manual adjustment of the zero point or endpoint of the valve after auto calibration. Once you enter the TVL ZERO (or TVL ENd) setting, press the UP/DOWN button to change the zero point (or endpoint) of the valve, and then press the ENTER button to save it. The saved position is recognized as the zero (or endpoint) of the valve.

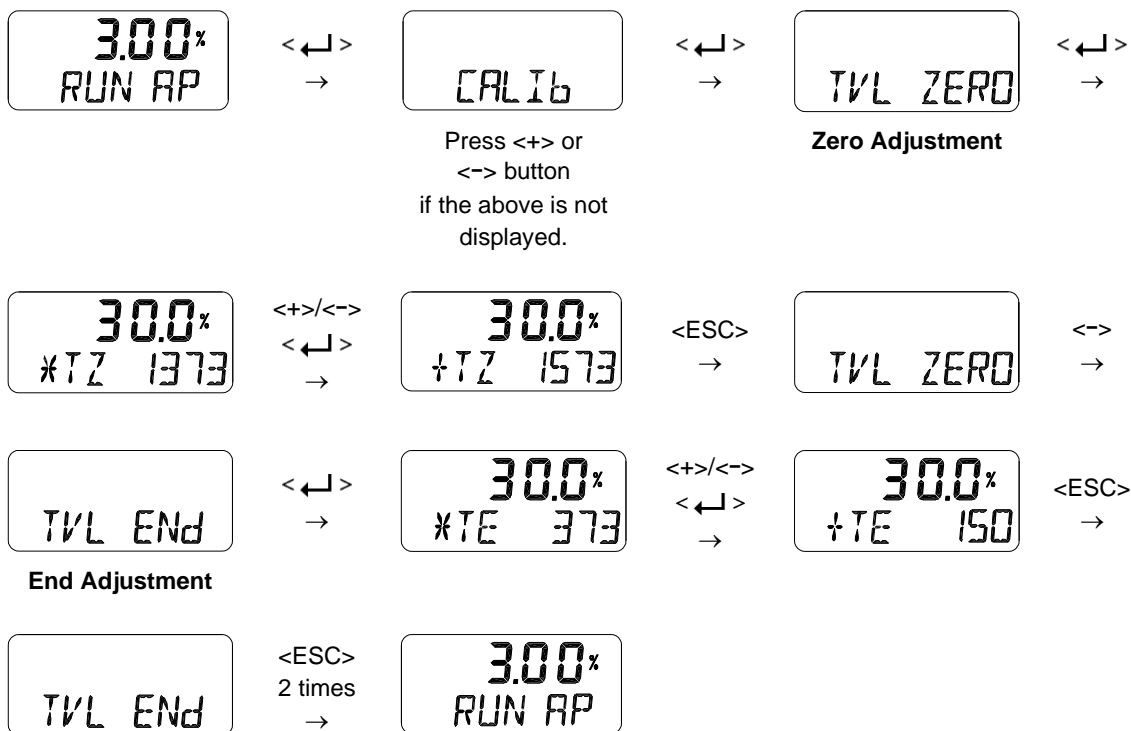

8.7 Manual Operation (MAN OPER)

It is used to manually raise or lower the valve stem by operating the <+> or <-> buttons. This can be used to observe the move of valve stem without any external input signals. When engaged, the current input signal to the positioner has no effect on the positioner.



**Manual operation may affect the process in service, so use this function when the process is down or when it is acceptable to shut down the process.**

8.7.1 Manual Operation by Set position (MAN SP)

The target position is incremented by the <+> and <-> buttons based on the currently entered set position values, which moves the stem of the valve up and down. Once out of the menu by <ESC>, the positioner is controlled again by an input signal.

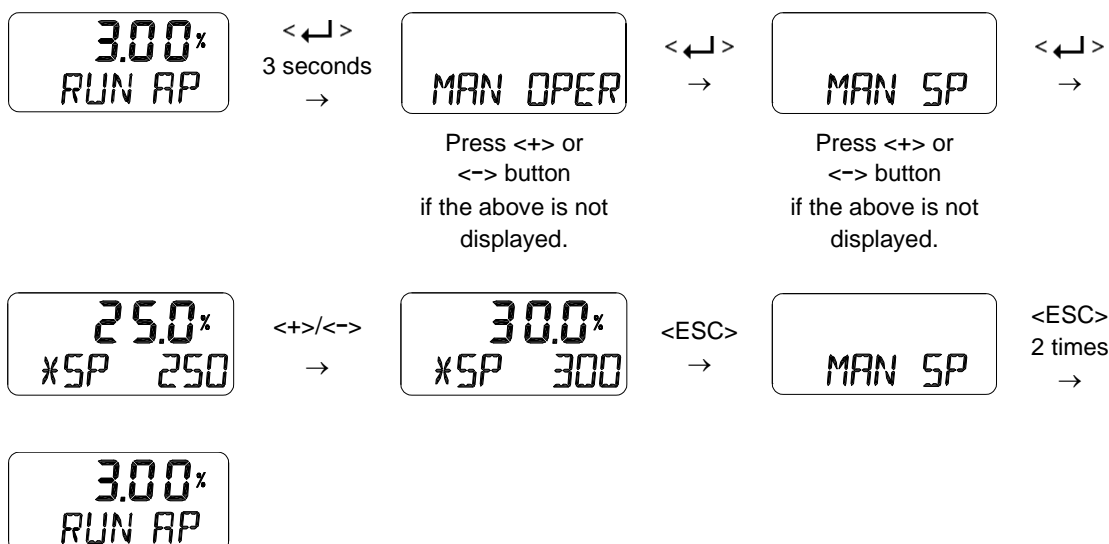

8.7.2 Manual Operation by Manipulator Value (MAN MV)

The input to I/P converter is incremented or decremented by the <+> and <-> buttons based on the currently entered I/P input value, which moves the stem of the valve up and down. Once out of the menu by <ESC>, the positioner is controlled again by an input signal.

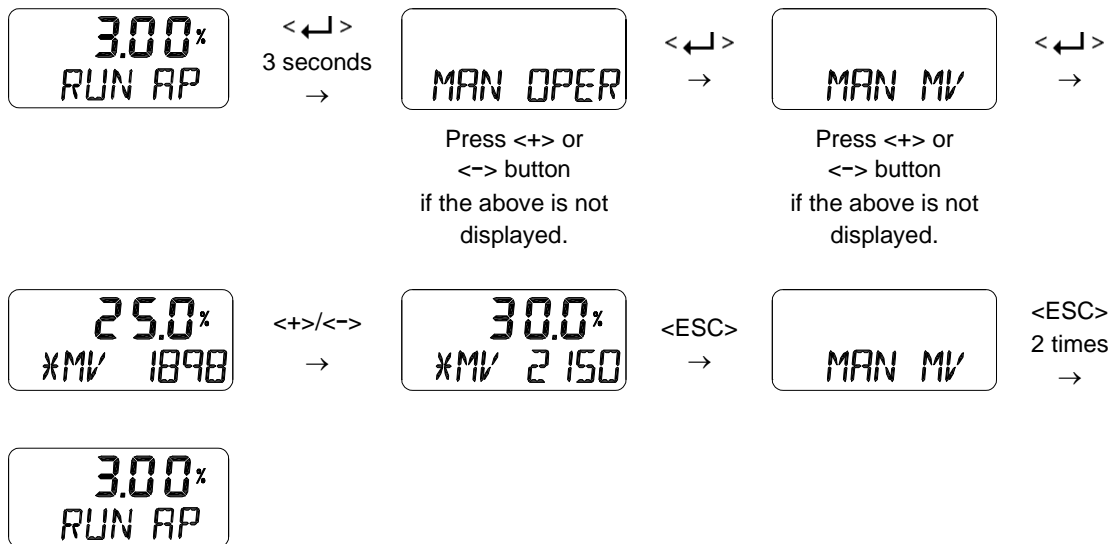

8.8 Control Parameters (CTL PARM)

Followings are the values changeable at the Control Parameters Mode.

- 1) Dead Band (dEAdbANd)
- 2) Forward P parameter (KP UP) and reverse P parameter (KP dN)
- 3) Forward Integral time parameter (TI UP) and reverse Integral time parameter (TI dN)
- 4) Forward D parameter (Kd UP) and reverse D parameter (Kd dN)
- 5) GAP Parameter (GAP)
- 6) GAP P Parameter (GP)
- 7) GAP I Parameter (GI)
- 8) GAP D Parameter (Gd)
- 9) Auto Dead band Mode (AUTO db)
- 10) Performance Mode (PER)

8.8.1 Dead Band (dEAdbANd)

Deadband indicates the size of the allowable deviation that is set near the target position. If the valve has large packing friction, this value can be adjusted and set accordingly to prevent the limit cycle caused by the friction. If the deadband is set to 0.5 %, its range is  $\pm 0.5$  % of the target.

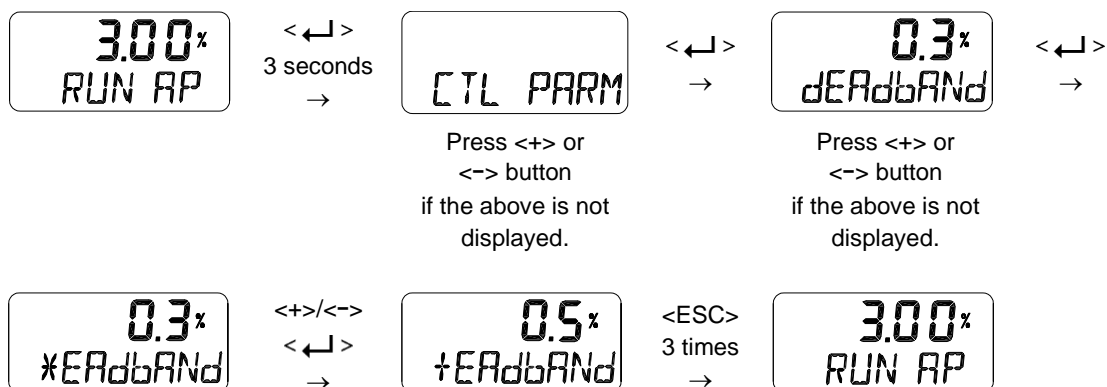

8.8.2 Forward P parameter (KP UP) and reverse P parameter (KP dN)

The KP parameter is the proportional control constant to the calibration signal to reduce the error between the target position and the current position, the KP UP is applied when the valve moves in the direction of increasing output air pressure, and KP dN is applied when the valve moves in the direction of venting output air pressure. A larger value of gains "KP UP" or "KP dN" moves the valve faster to reach a target position, but the valve tends to oscillate if set to high. In contrast, smaller gains improve stability, but make it slower to reach a target position.

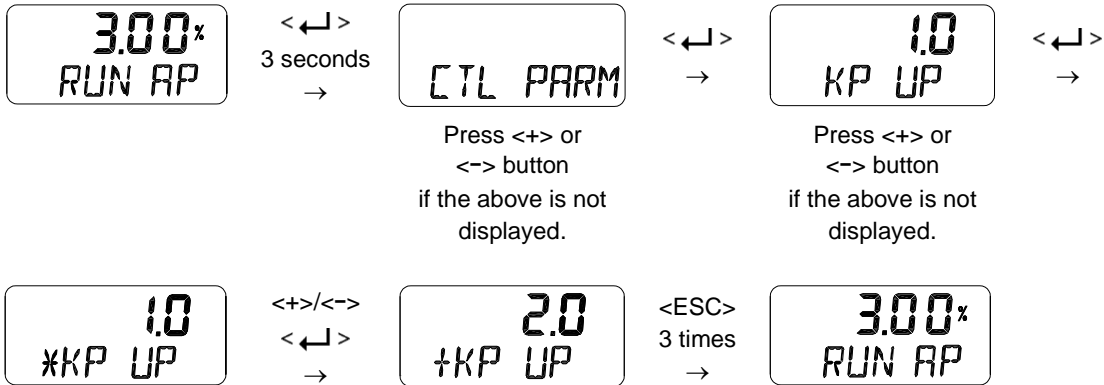

8.8.3 Forward Integral time parameter (TI UP) and reverse Integral time parameter (TI dN)

TI parameters are an integral value that add the error correction signal to the existing calibration signal, TI UP is applied when the valve moves in the direction of increasing the output air pressure, and TI dN is applied when the valve moves in the direction of decreasing the output air pressure. A smaller TI makes the valve faster to reach a target position and tends to cause oscillation.

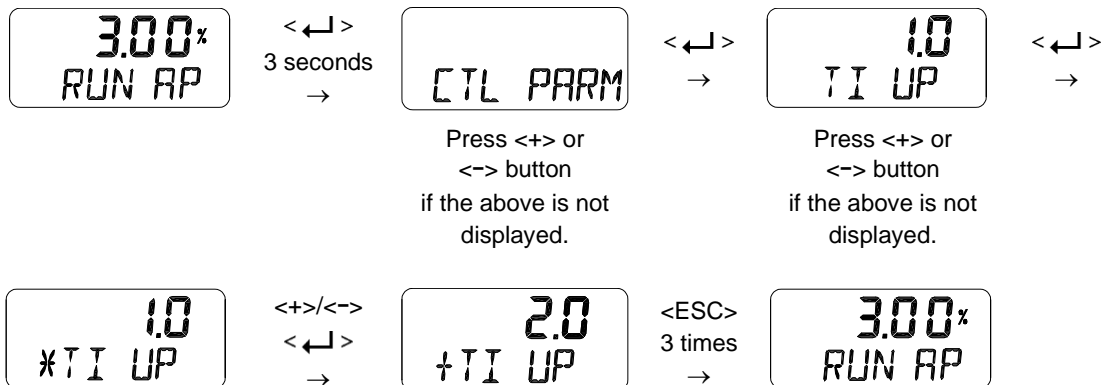



### 8.8.4 Forward D parameter (Kd UP) and reverse D parameter (Kd dN)

The Kd parameter is a differential value that adds the correction signal due to the rate of error to the existing calibration signal. Kd UP is applied when the valve moves in the direction of increasing output air pressure, and Kd dN is applied when the valve moves in the direction of decreasing output air pressure. A larger D value makes the valve hunting easier, and a smaller value can lead to poor linearity or dynamic properties.

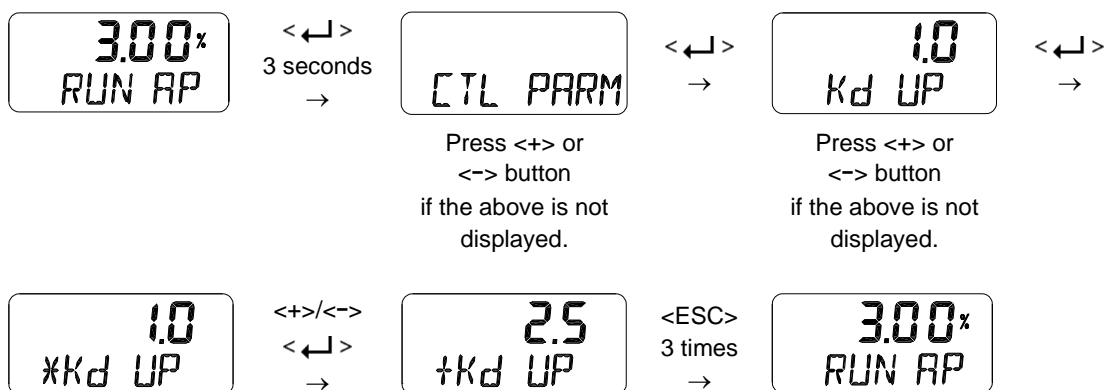

### 8.8.5 GAP Parameter (GAP)

The GAP parameter sets the control range at which Gap control begins. If the current position of the valve falls within the setting range GAP (%) relative to the final target position (target position ± GAP), Gap control operates along with PID Control. When the GAP control begins, the PID GAP parameters (GAP P, GAP I and GAP D) interacted with the PID parameters (KP, KI and KD) are applied to valve control.

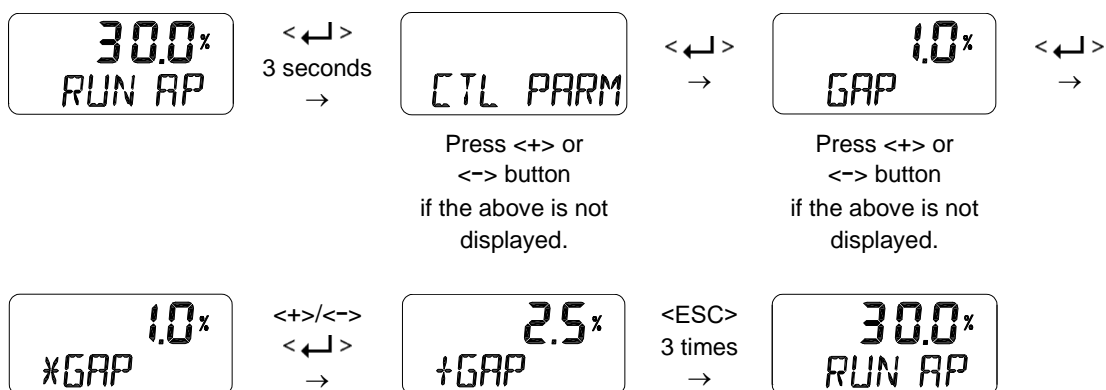

### 8.8.6 GAP P parameter (GP)

GP is a proportional gain. If the valve position is within the GAP parameter range, a proportion gain created based on KP and GP is applied to valve control.

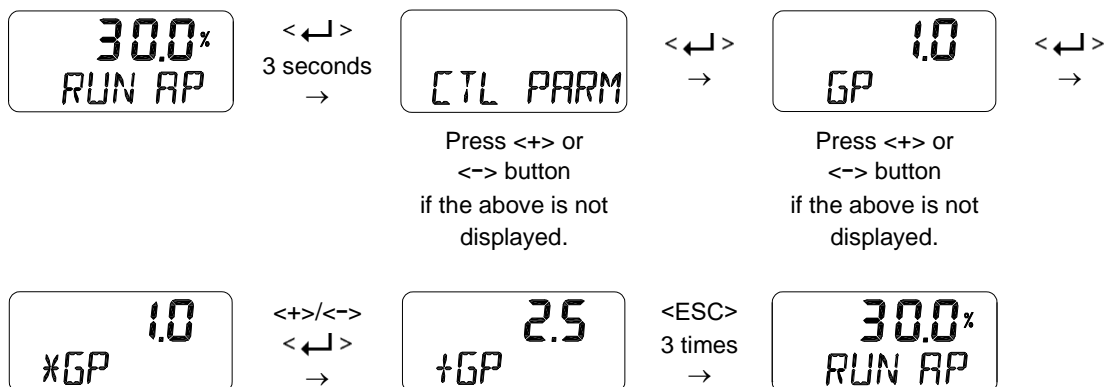

### 8.8.7 GAP I parameter (GI)

GI is an integral gain. If the valve position is within the GAP parameter range, an integral gain created based on 1/TI and GI is applied to valve control.

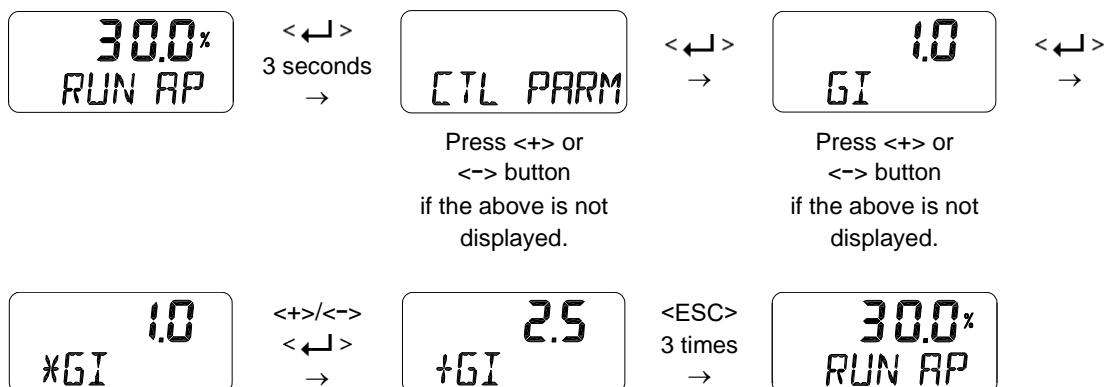

### 8.8.8 GAP D parameter (Gd)

Gd is a differential gain. If the valve position is within the GAP parameter range, a differential gain created based on Kd and Gd is applied to valve control.

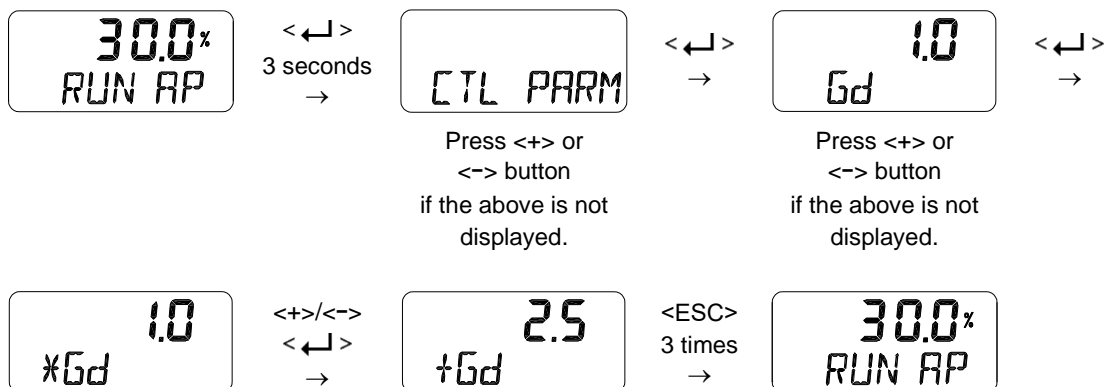

8.8.9 Auto Dead band Mode (AUTO db)

This function is used to suppress a hunting for valves with high static friction. The initial value is OFF and it shall be set to 0 % to activate the auto dead band automatically. The value is changed to a proper value once this mode is activated.

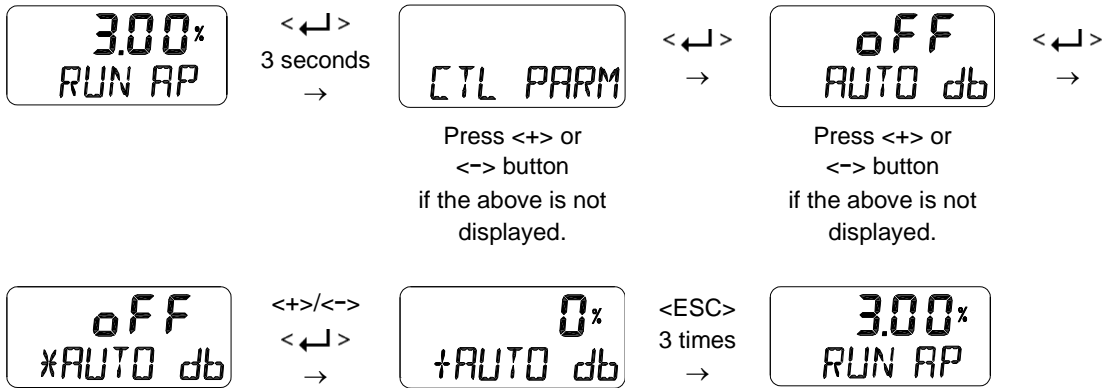

8.8.10 Performance Mode (PER)

This mode has three modes of operation: Stable, Normal, and Fast that allow you to select the required responsiveness. The performance modes indicate the response characteristics from slow response to quick response in the order of Stable, Normal and Fast.

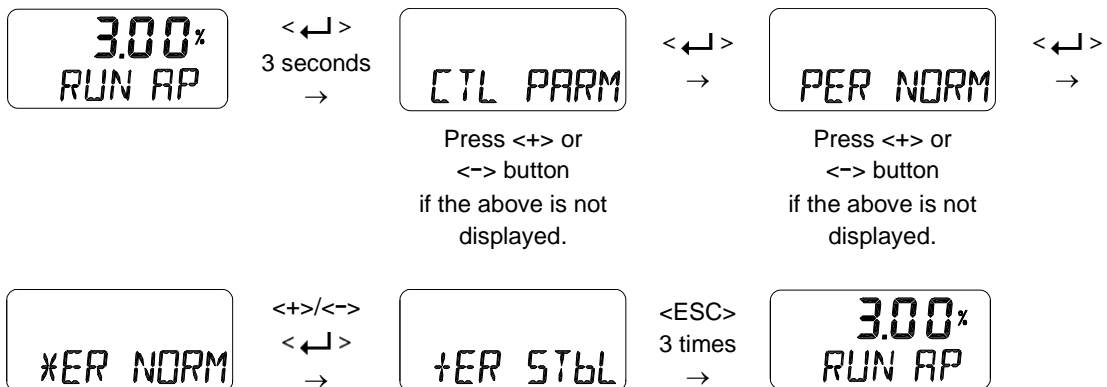

### 8.9 Input Configuration (IN CFG)

Followings are the values changeable at the Input Configuration Mode.

- 1) Signal Direction (SIG NORM / REVS)
- 2) Split Range Mode (SPLIT)
- 3) Custom Split Range Zero (CST ZERO)
- 4) Custom Split Range End (CST ENd)
- 5) Characterization Curves (CHAR)
- 6) User Set Characterization 5 Points (U5)
- 7) User Set Characterization 21 Points (U21)
- 8) Tight Shut Open (TSHUT OP)
- 9) Tight Shut Close (TSHUT CL)
- 10) Target Position Ramp Up Rate (RAMP UP) and Target Position Ramp Down Rate (RAMP dN)
- 11) Digital Input Function (dIF), (Applicable to 6 Communication “5” of Product Code)
- 12) Digital Input Logic (dI LOGIC) , (Applicable to 6 Communication “5” of Product Code)

#### 8.9.1 Signal Direction (SIG NORM / REVS)

This function changes the action type of the valve, NORM or REVS. if NORM is selected, the air is completely released through output port 1 of the positioner when 4 mA is applied, and the maximum air pressure is loaded to the actuator through output port 1 when 20 mA is applied. If set to REVS, the maximum air pressure is loaded to the actuator via output port 1 when an input current of 4 mA is applied to the positioner.

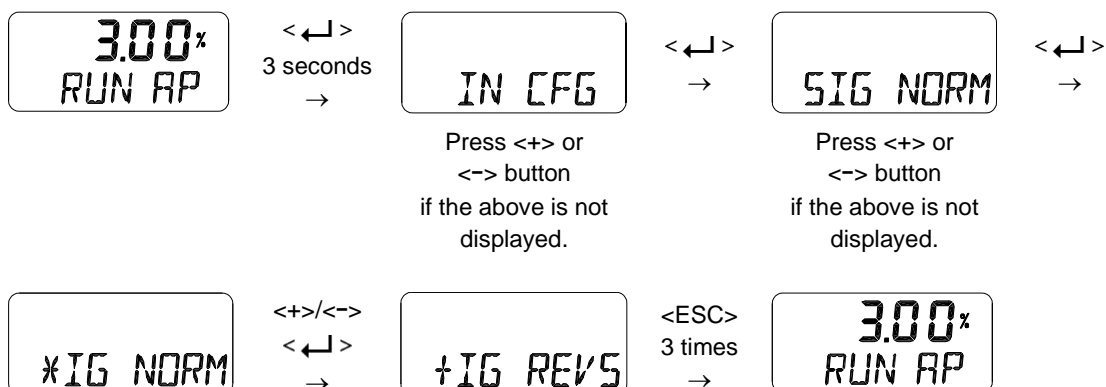

### 8.9.2 Split Range Mode (SPLIT)

This is used to set the range of the input signal to control the entire stroke of the valve. You can select one of the four input signals that consists of 4 ~ 20 mA, 4 ~ 12 mA, 12 ~ 20 mA, and user settings (Custom, CSt). 4 ~ 20 mA is the factory setting.

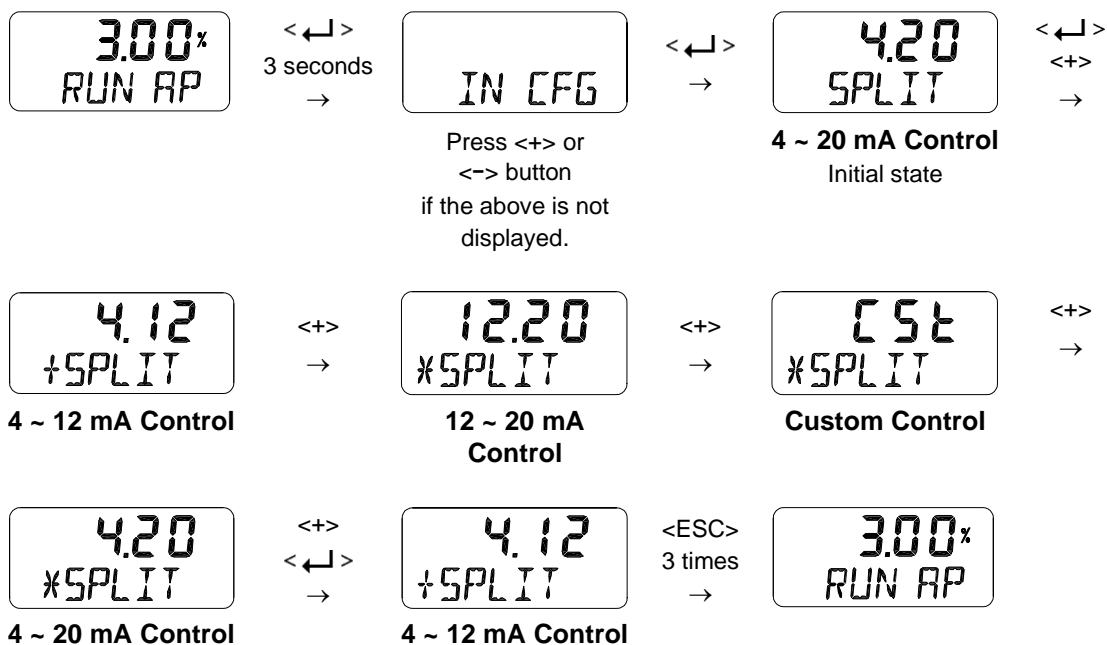

### 8.9.3 Custom Split Range Zero (CST ZERO)

It is used to set the current corresponding to the zeropoint when the valve position of 0 to 100 % is controlled by the user-set CUSTOM. For example, if the valve is controlled by 6 ~ 20 mA instead of 4 ~ 20 mA, CST ZERO is 6 mA. However, the difference of the current between the origin point and the endpoint must be greater than 4 mA.

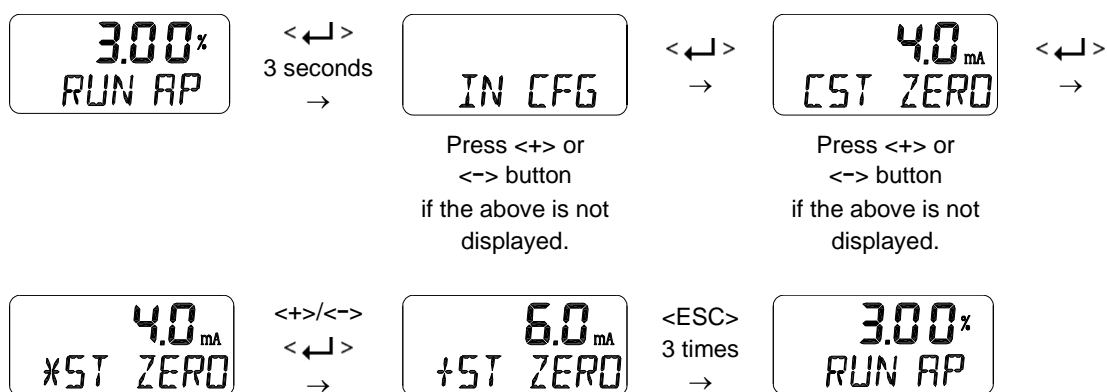

This function is activated by saving the Split Range Mode (SPLIT) of above Section 8.9.2 as "CSt".

8.9.4 Custom Split Range End (CST END)

It is used to set the current corresponding to the endpoint when the valve position of 0 to 100 % is controlled by the user-set CUSTOM. For example, if the valve is controlled by 4 ~ 18 mA instead of 4 ~ 20 mA, CST END is 18 mA. However, the difference of the current between the origin point and the endpoint must be greater than 4 mA.

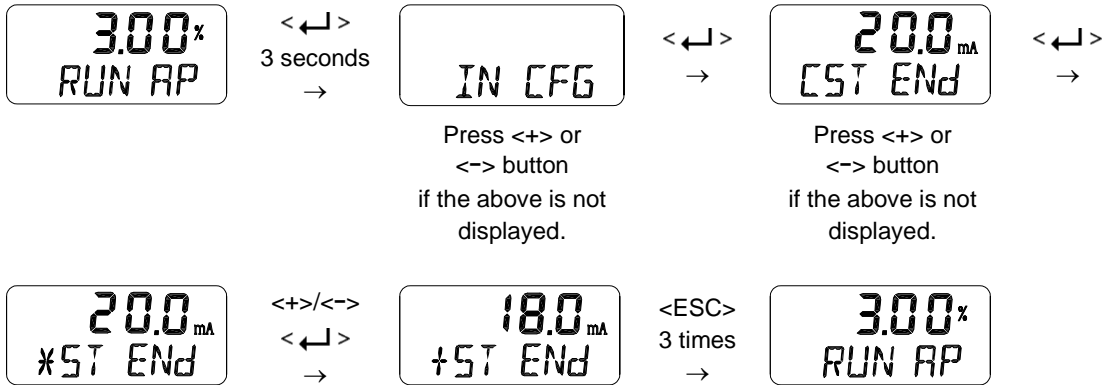

This function is activated by saving the Split Range Mode (SPLIT) of above Section 8.9.2 as “CSt”.

8.9.5 Valve Flow Characterization Curves (CHAR)

The flow characteristic curve of valve is available by selecting one of the following: Linear(LIN), Quick Open(QO), Equal Percentage(EQ), User Set Characterization 5 Points (U5) and User Set Characterization 21 Points(U21).

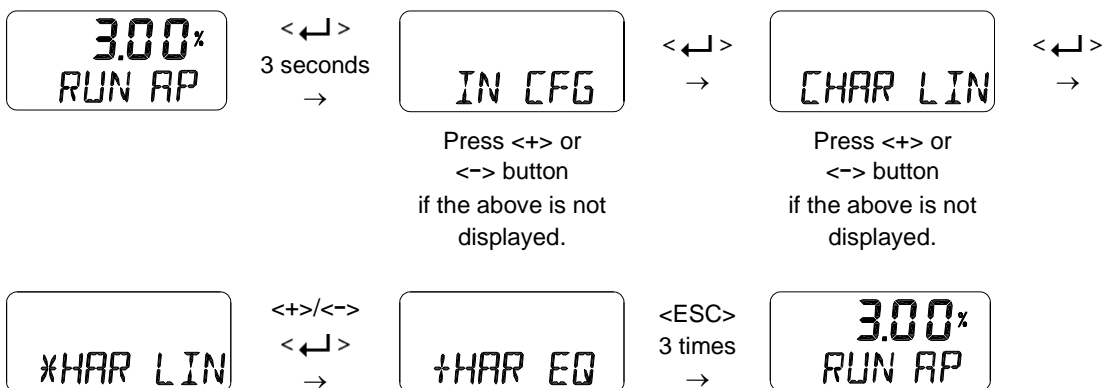
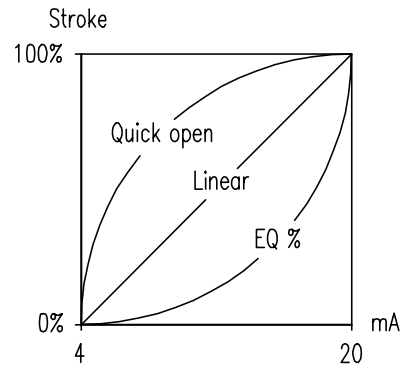

8.9.6 User Set Characterization 5 Points (U5)

A total of 5 target positions are set every 4 mA intervals. When shipped from the factory, the initial positions are P0 (4 mA, 0 %), P1 (8 mA, 25 %), P2 (12 mA, 50 %), P3 (16 mA, 75 %), and P4 (20 mA, 100 %). User can change all 5 points or only change partially and exit the menu by pressing <ESC> button.

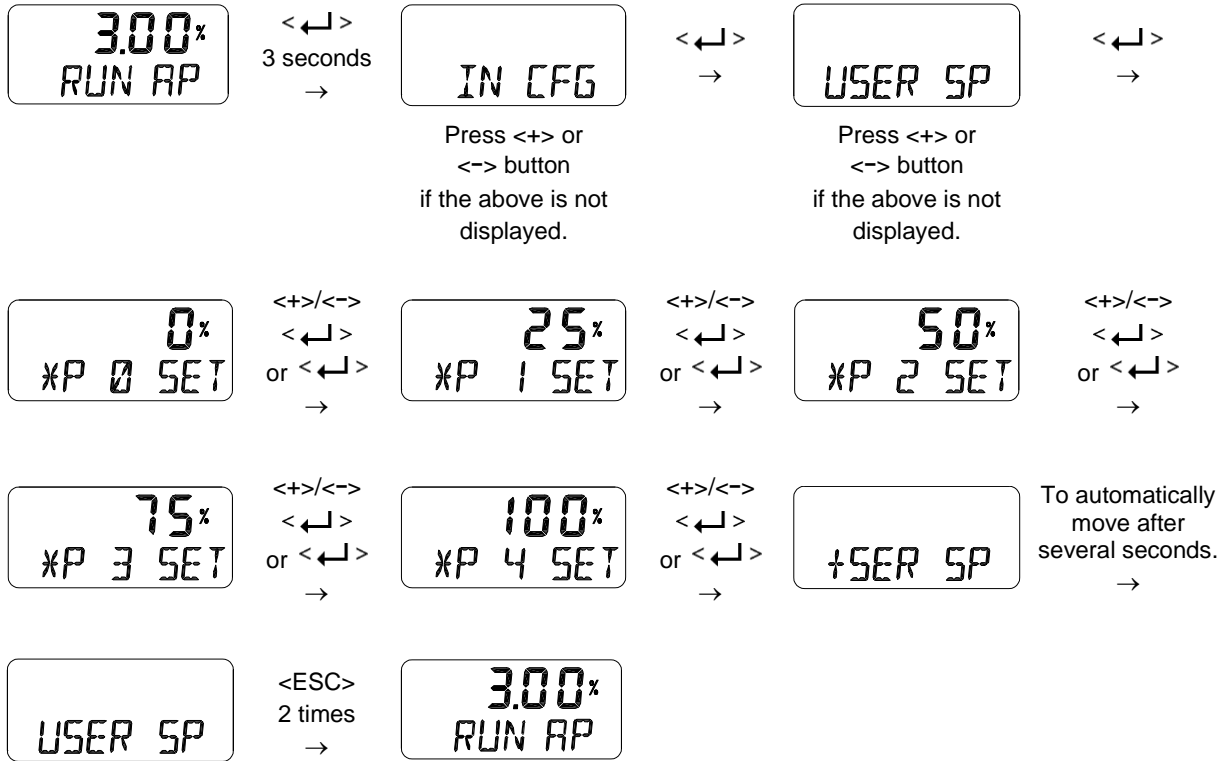

This function is activated by saving the Valve Flow Characterization Curves (CHAR) of above Section 8.9.5 as "U5".

8.9.7 User Set Characterization 21 Points (U21)

A total of 21 target points can be set every 0.8 mA intervals. When shipped from the factory, the initial P0 (4 mA, 0 %), P1 (4.8 mA, 5 %), P2 (5.6 mA 10 %), - - -, P19 (19.2 mA, 95 %), and P20 (20 mA, 100 %). For example, a characteristic curve below can be made through the settings of P1 to P20. User can change all 21 points or only change partially and exit the menu by pressing <ESC> button.

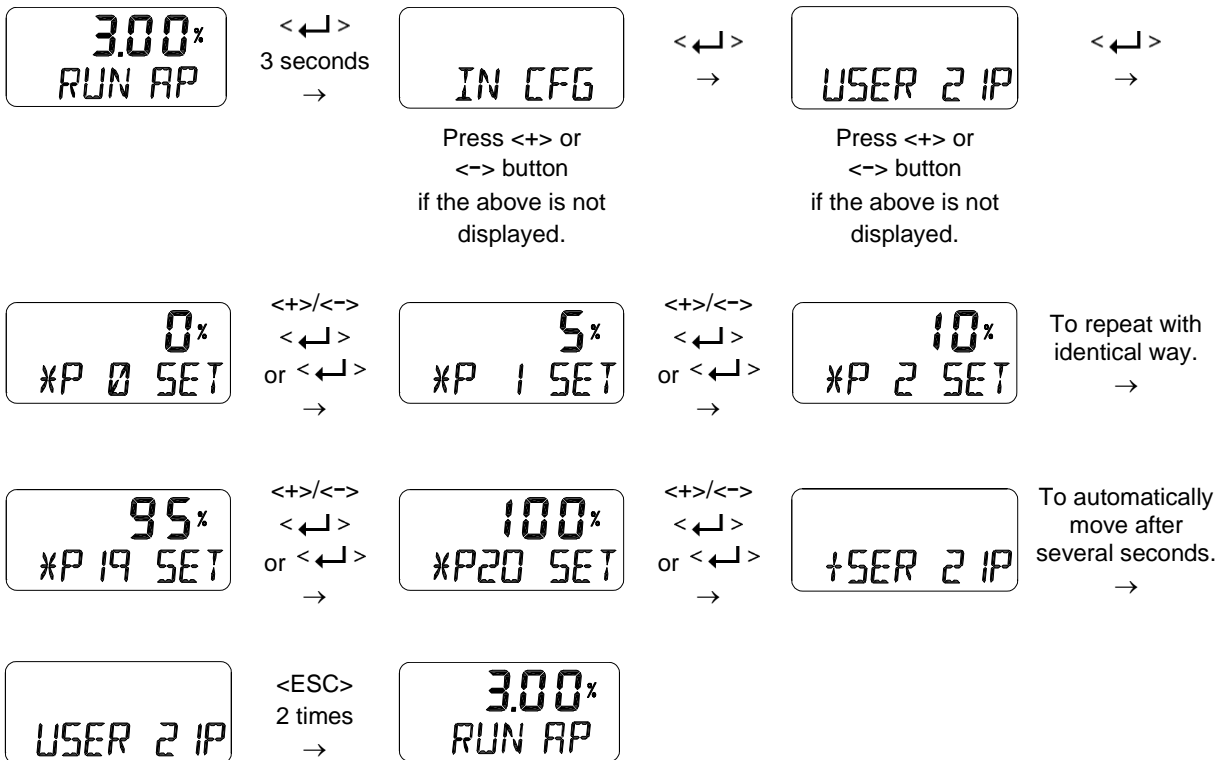
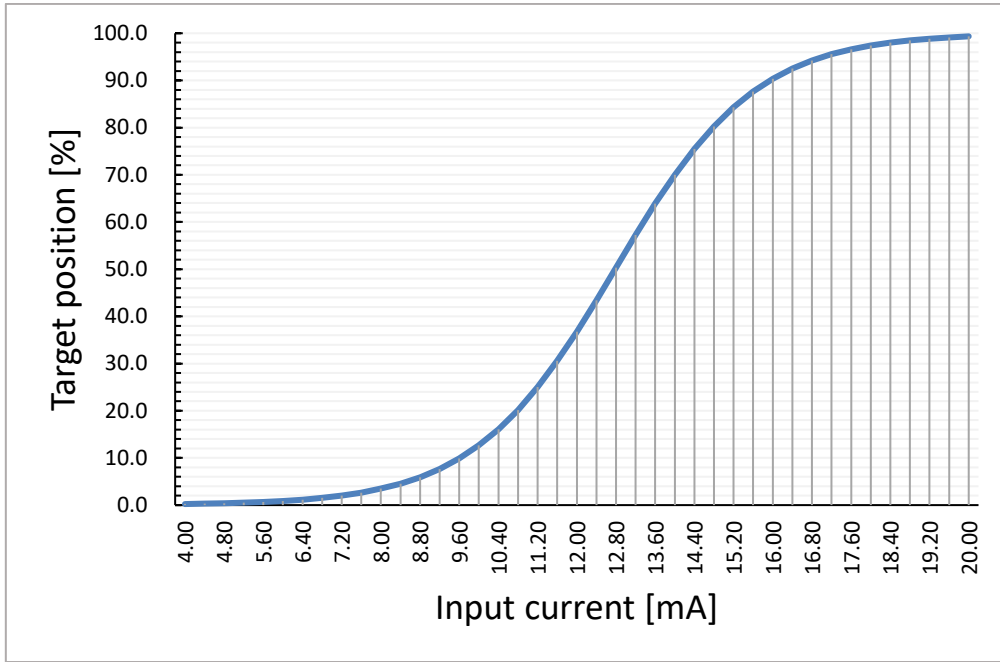

This function is activated by saving the Valve Flow Characterization Curves (CHAR) of above Section 8.9.5 as "U21".



8.9.8 Tight Shut Open (TSHUT OP)

It is used to ensure that the valve is fully opened with a large force. When the input signal SP is greater than the value set in the TSHUT OP, all available force is applied to OUT 1 port to tightly open the valve. If the input current of 4 mA is 0% of valve position and 20 mA is 100% of valve position, and the Tight Shut Open value is set to any position less than 100 % (e.g. 95 %), then the valve stroke will be 100 % immediately when the input signal is over the set value (e.g. 95 %). A full supply pressure applied to the actuator via the OUT1 port prevents leakage of the valve by shutting the valve tightly. However, when the value is set to 100 %, Tight Shut Open function doesn't work.

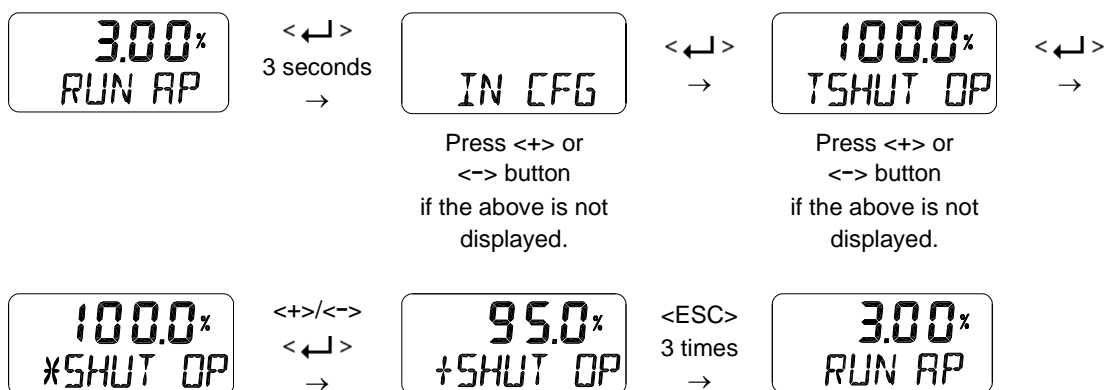

### 8.9.9 Tight Shut Close (TSHUT CL)

It is used to ensure that the valve is fully closed with a large force. When the input signal SP is smaller than the value set in the TSHUT CL, air pressure is vented through OUT 1 port to tightly close the valve. If the input current of 4 mA is 0 % of valve position and 20 mA is 100 % of valve position, and the Tight Shut Close value is set to any position larger than 0 % (e.g. 5 %), then the valve stroke will be 0 % immediately when the input signal goes below the set value (e.g. 5 %). The air venting from the actuator via the OUT1 port prevents leakage of the valve by shutting the valve tightly. However, when the value is set to 0 %, Tight Shut Close function doesn't work.

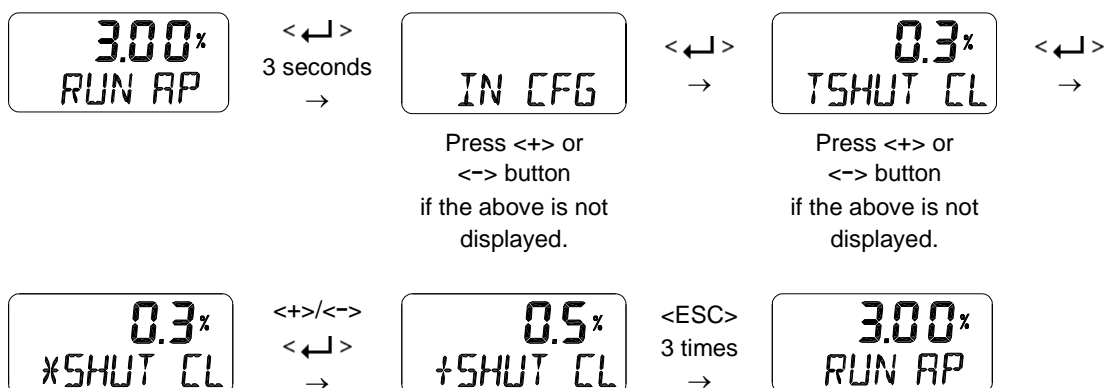

The following graph shows the operation of the valve stroke when the input signal corresponding to Tight Shut Open or Tight Shut Close is applied to the device.

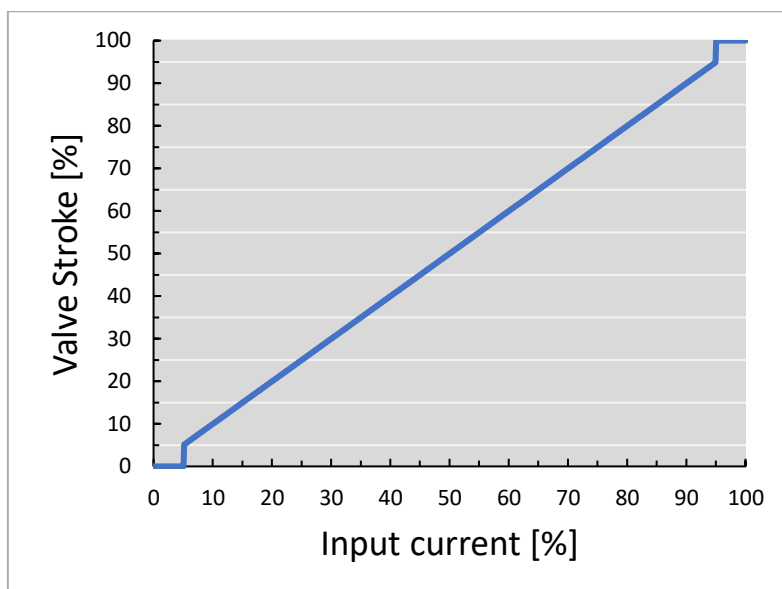

### 8.9.10 Target Position Ramp Up Rate (RAMP UP) and Target Position Ramp Down Rate (RAMP dN)

It is used to prevent the valve from moving too fast when the process to be controlled is too sensitive to rapid changes in flow or pressure. The unit of setting is %/sec. If you want to move 100 % of the stroke for about 5 seconds, set it to 20 [%/sec]. The rising and falling speed can be set independently, and the valve will move to the target position as soon as possible when this function is switched off.

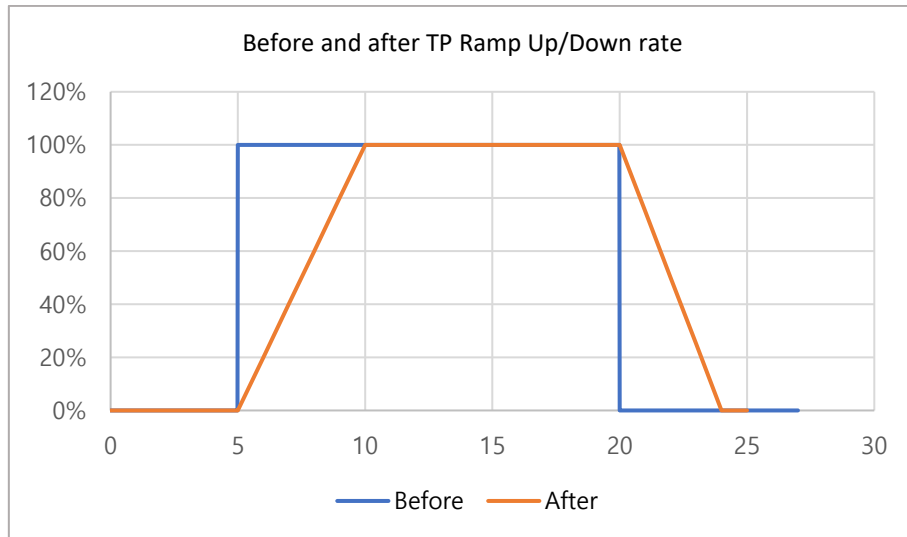

The curves below show the target position (red) and the actual position (blue) of the valve after applying SP Ramp Up/Down rate.

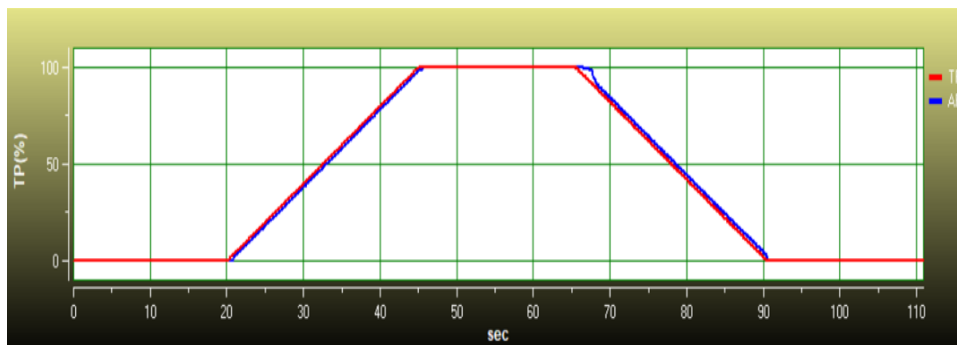

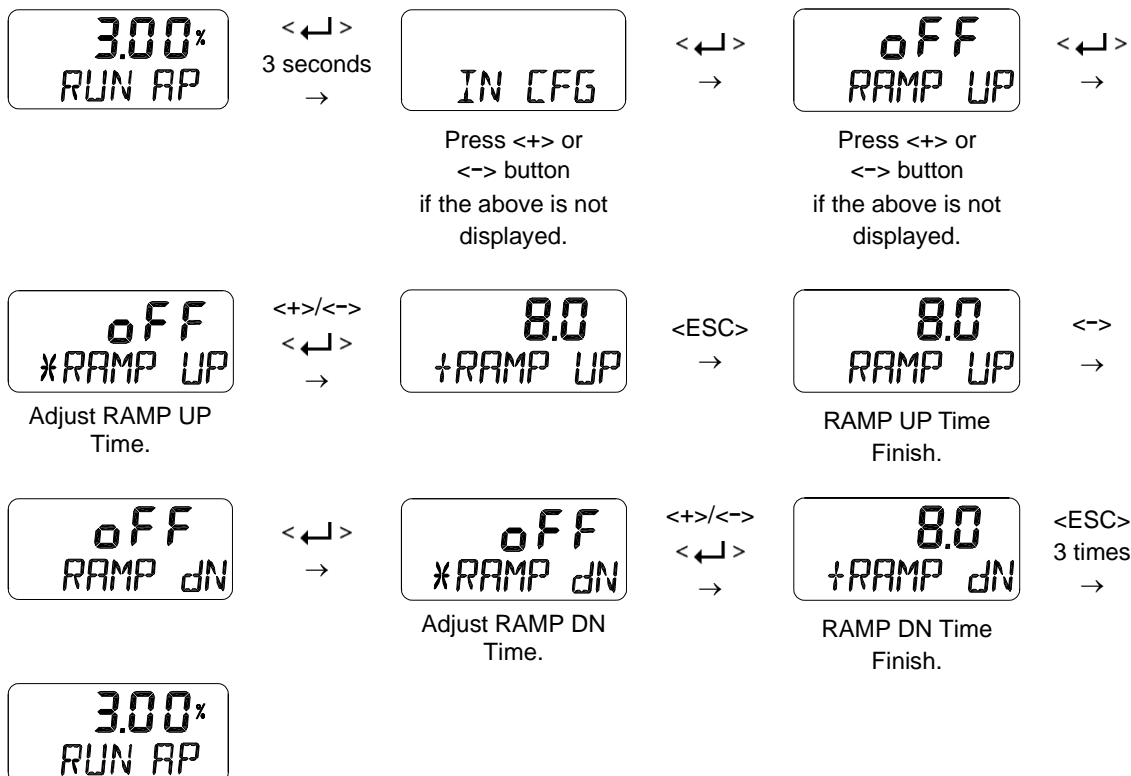

8.9.11 Digital Input Function (dIF)

(Applicable to **6** Communication “5” of Product Code)

It is used to perform a specific function as the signal is activated on the digital input port. The dIF should be configured taking into account Digital Input Logic of Section 9.9.12.

Function name	Abbreviation on LCD	Description
OFF	OFF	Not performing any function.
Fully Closed Position	FCL	Valve moves to a fully closed position, i.e. safe position.
Fully Open position	FOP	Valve moves to a fully open position.
Partial Stroke Test Start	PSTA	Start Partial Stroke Test
Partial stroke Test Stop	PSTO	Stop Partial Stroke Test in progress

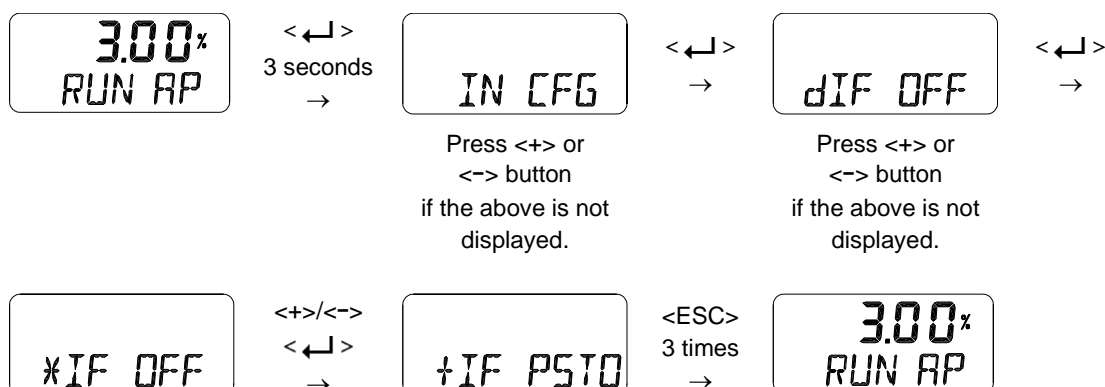

8.9.12 Digital Input Logic (dI LOGIC)

(Applicable to **6** Communication "5" of Product Code)

It sets the logic that activates digital input to High (HI) or Low (Lo). The initial factory setting is HI, which means that when 11 ~ 28 V DC voltage is applied, it is recognized as HI state. If Lo is set, when 0 ~ 5V is applied or the electric power is disconnected, it is recognized as Lo state.

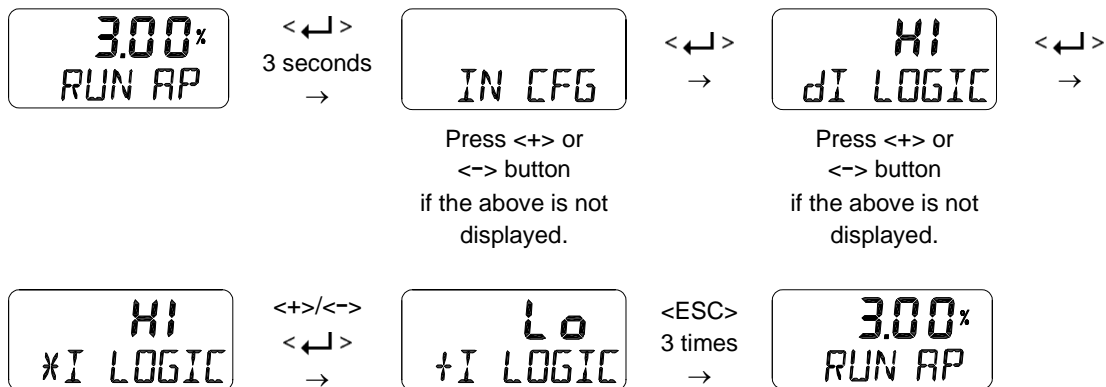

### 8.10 Output Configuration (OUT CFG)

Followings are the values changeable at the Output Configuration Mode.

- 1) Position Transmitter Direction (PTM NORM / REVS)
- 2) Position Transmitter Zero / End (PTM ZERO / ENd)
- 3) HART Feedback Direction (HT NORM / REVS)
- 4) Back Calculation (bACKCAL oFF / on)
- 5) Limit Switch Mode (LS MOdE oFF/ on), (This function is available when either 6 Communication "5" or 7 Output Option "2" or "3" of Product Code is selected.)
- 6) Digital Output Function (dO1 or dO2 OFF / ...), (Applicable to 6 Communication only "5" of Product Code)
- 7) Digital Output Logic (dO1 or dO2 LOGIC HI / Lo), (This function is available when either 6 Communication "5" or 7 Output Option "2" or "3" of Product code is selected.)
- 8) Analog Output Function (AOF OFF / ...), (This function is available when both 6 Communication "5" and 7 Option "1" or "3" of of Product Code are selected simultaneously.)
- 9) Analog Output Logic (AO LOGIC Lo / HI), (This function is available when both 6 Communication "5" and 7 Option "1" or "3" of of Product Code are selected simultaneously.)

#### 8.10.1 Position Transmitter Direction (PTM NORM / REVS)

The analog feedback signal from the positioner can be changed to normal (NORM) or reverse (REVS), which means they are the same or reversed direction as the actual position.

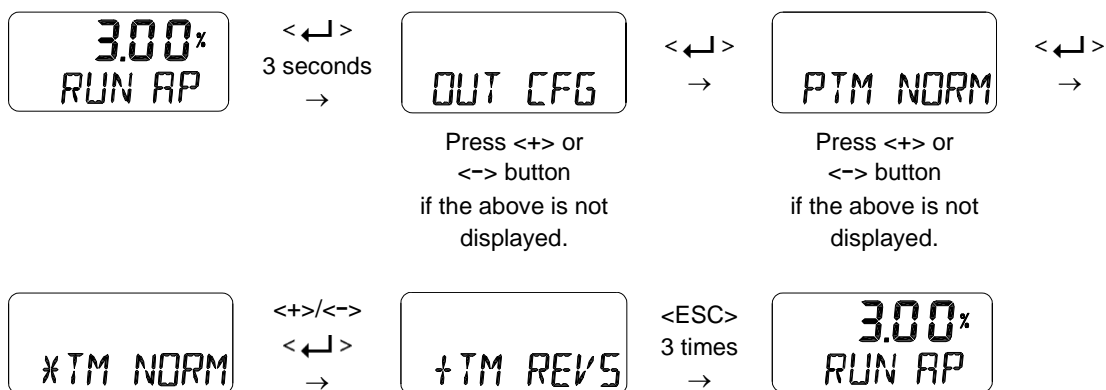

8.10.2 Position Transmitter Zero / End (PTM ZERO / ENd)

ZERO adjusts the zero point of the position transmitter (4 mA feedback), and ENd adjusts the end point of the transmitter (20 mA feedback). This is used when the analog output signal needs to be feedbacked differently than the actual position of the valve, or to be adjusted a little. A measuring instrument such as an ampere meter is needed to view the analog output signal, and it should be connected as shown below.

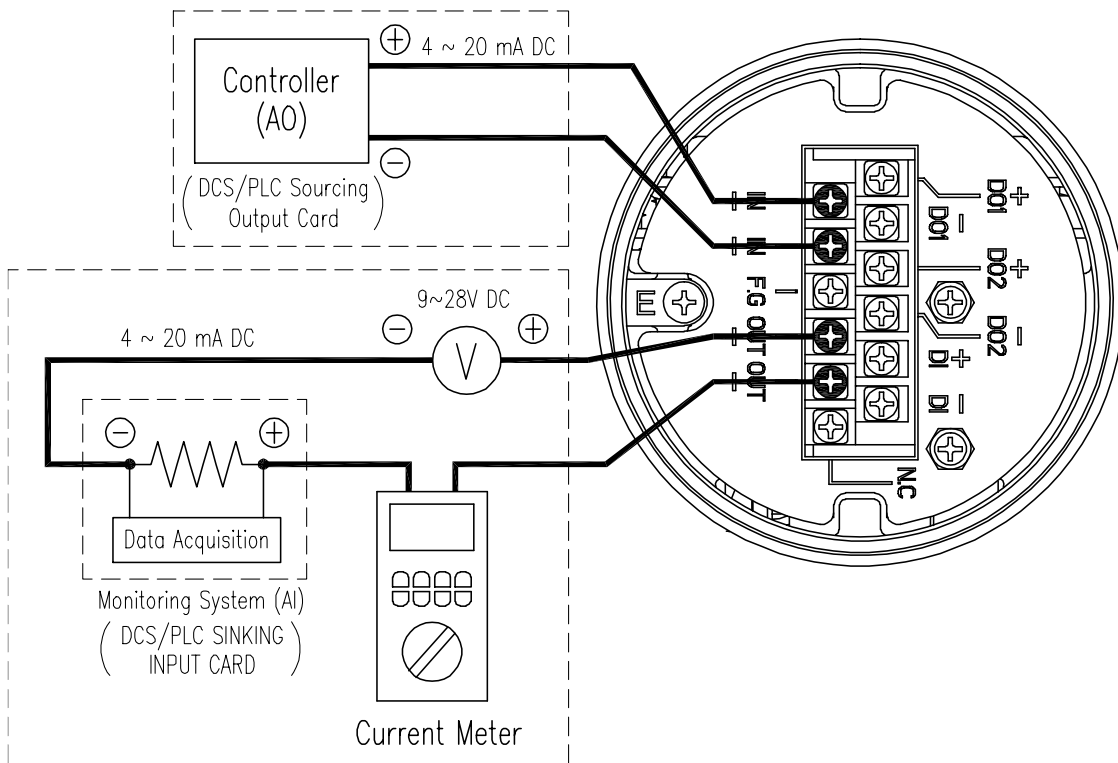
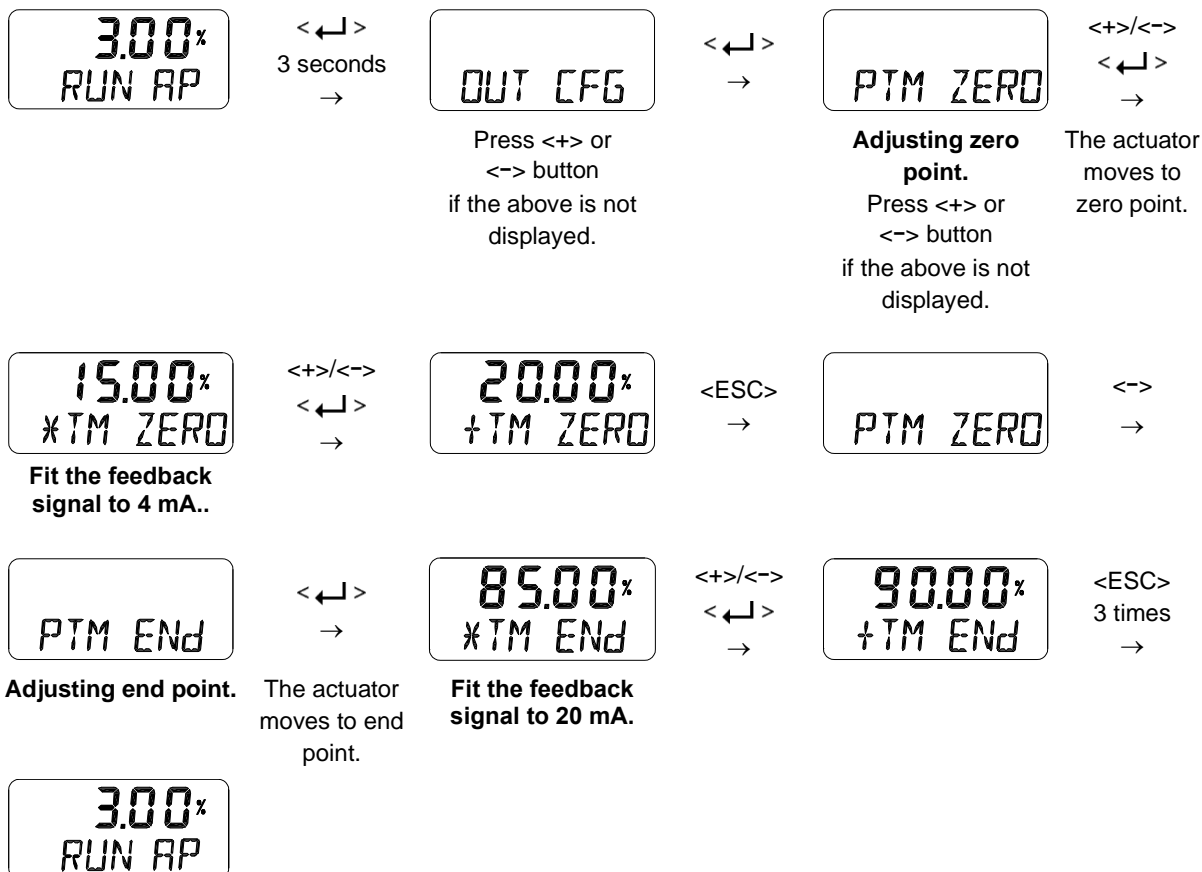
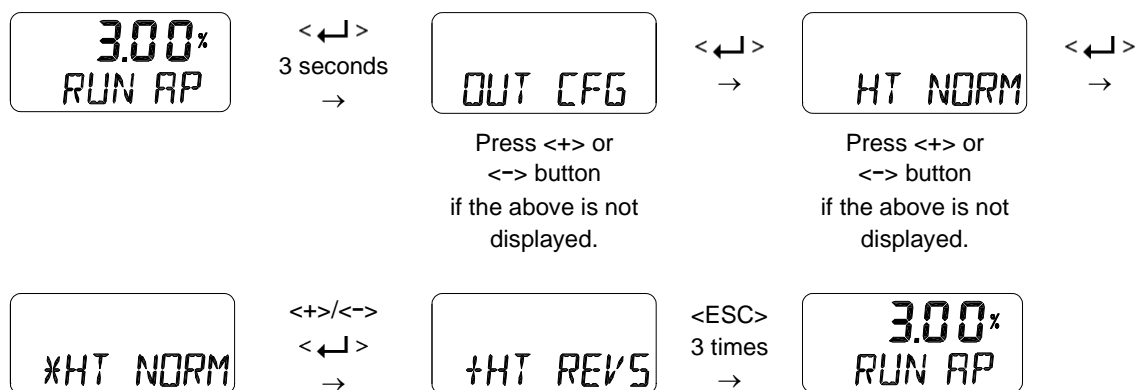

Fig. 8-3: Setting transmitter



### 8.10.3 HART Feedback Direction (HT NORM / REVS)

The feedback signal from the HART communication output of the positioner can be output in the same direction or the reversed direction as the actual position of the valve. NORM or REVS is selected.





### 8.10.4 Back Calculation (bACKCAL OFF / on)

This function recalculates the output "RUN AP" value changed by the flow characteristics setting mode to display it linearly proportional to actual input current. For example, if the flow characteristic mode is set from "LIN" to "EQ", when an input current value of 8 mA (25 %) is applied, the target position is changed to 6.25 % and "RUN AP" is displayed as 6.25 % after the move. If you change the bACKCAL from OFF to ON, the "RUN AP" is displayed as 25 %.

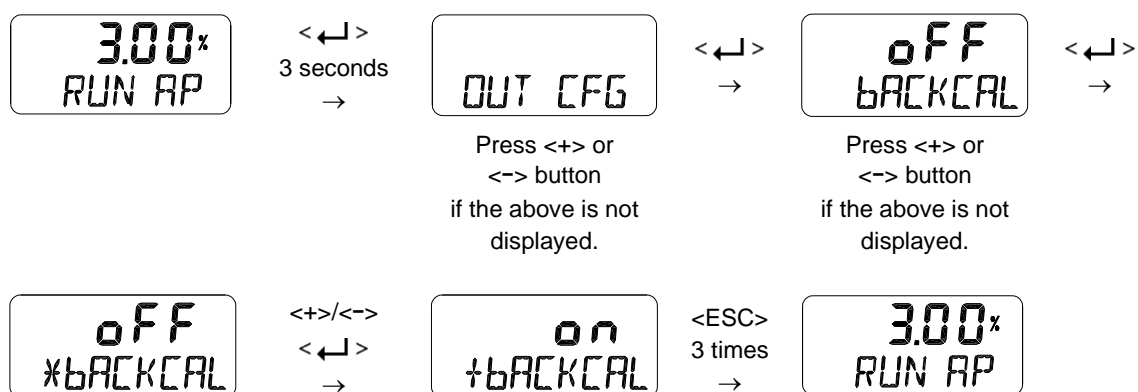

### 8.10.5 Limit Switch Mode (LS MOdE OFF/ on)

**(This function is available when either 6 Communication "5" or 7 Output Option "2" or "3" of Product code is selected.)**

This parameter is used to set the Digital Output terminals to limit switches. The Digital Output 1 terminals (dO1+, dO1-) or the Digital Output 2 terminals (dO2+, dO2-) are set to the upper limit switch and lower limit switch, respectively. If this Limit Switch Mode is set to on, current flows through dO1+ and dO1- when the valve's position reaches 100 %, and current flows through dO2+ and dO2- when the valve's position reaches 0 %. Once this Mode is set to on, Digital Output 1 Function and Digital Output 2 Function are assigned to Travel Limit High (TVLH) and Travel Limit Low (TVLL), respectively. In addition, Digital Output 1 Logic (dO1 LOGIC) and Digital Output 2 Logic (dO2 LOGIC) are changed to HI and AL TVLH & AL TVLL corresponding to Travel High/Low Limit Alarm Enable is automatically changed to on. If either Digital Output 1 Function (dO1) or Digital Output 2 Function (dO2) is assigned to other function while the Mode is set to on, the Limit Switch Mode is automatically changed to OFF.

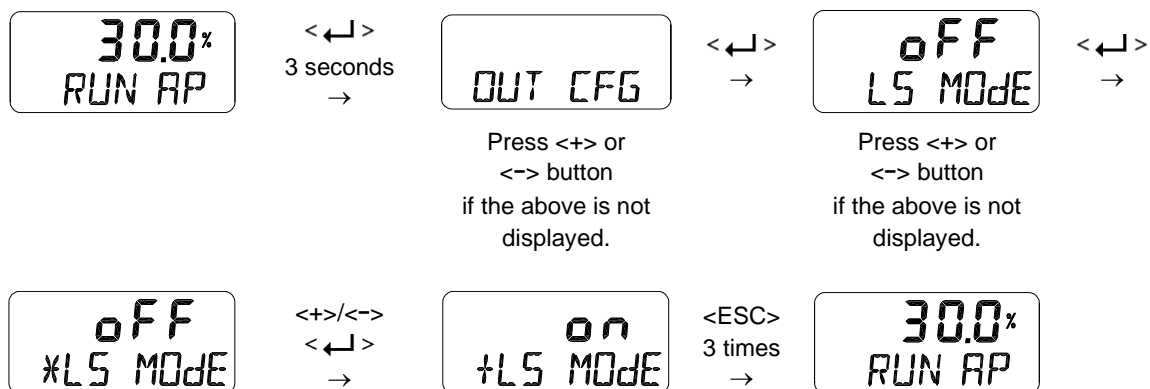

Note. Menu flow related to Limit Switch

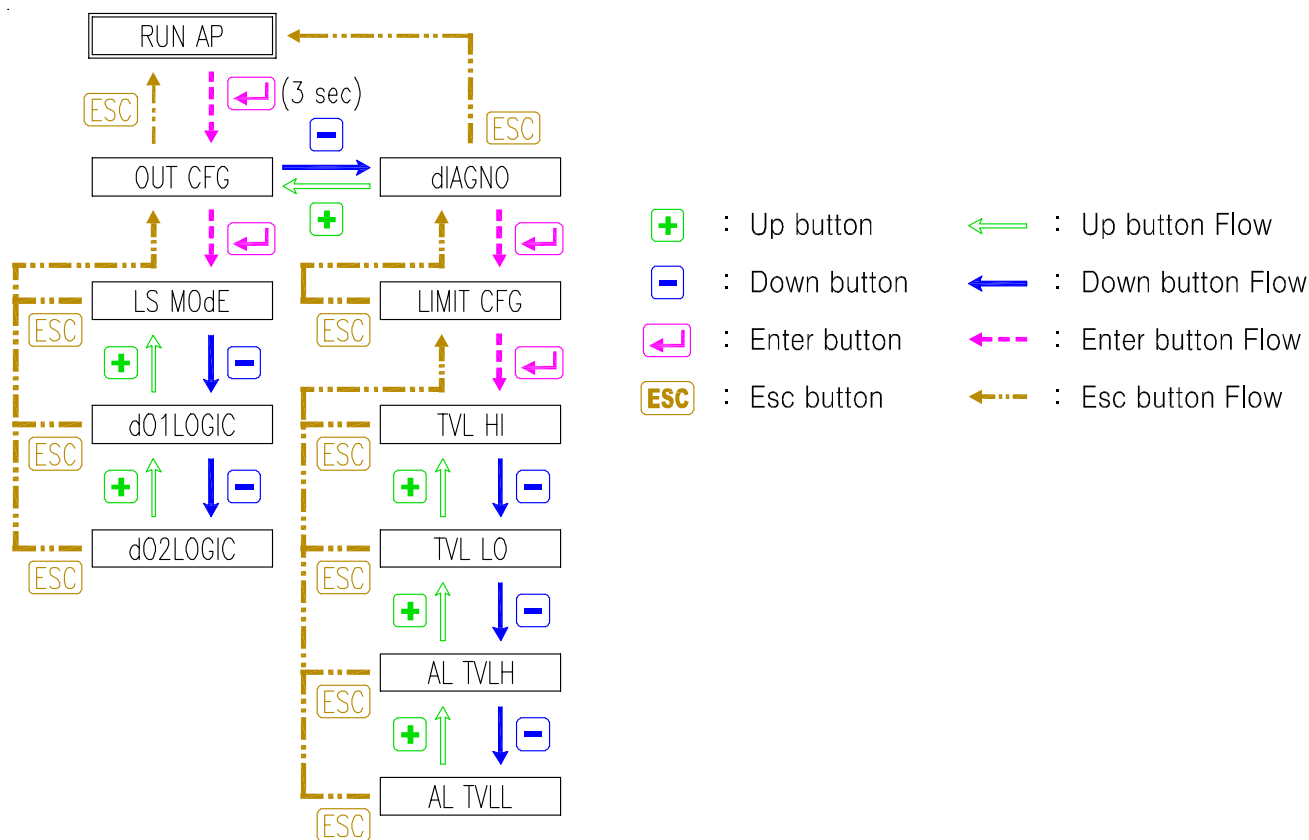

Menu name	Description
d01LOGIC (Digital Output 1 Logic for Travel Limit High)	It is used to set the logic that determines the state of the Digital Output switch to High(HI) or Low(Lo) when the valve reaches Limit High or Limit Low position. Logical switching state "oFF" which is defined as low: Current < 1 mA at 5 ~ 28 V Logical switching state "on" which is defined as high: Current > 2.2 mA at 5 ~ 28 V Refer to 8.10.7
d02LOGIC (Digital Output 2 Logic for Travel Limit Low)	
TVL HI (Travel Limit High) TVL LO (Travel Limit Low)	Parameters for upper and lower limits of valve opening that Limit Switches is activated. Refer to 8.12.5
AL TVLH (Travel High Limit Alarm Enable) AL TVLL (Travel Low Limit Alarm Enable)	Enabling alarms to occur when the valve reaches Limit High or Limit Low position. (8.12.5 Diagnostic Limit Configuration (LIMT CFG))

8.10.6 Digital Output Function (dO1 or dO2 OFF / ...)

This is used to output a specific alarm through the digital output port when triggered. Any of the alarms below can be configured to activate digital output. Assign any alarm to one of four NE107 signals to activate a digital output even when several alarms are triggered. The initial factory setting is OFF.

When assigning the digital output 1 and digital output 2 to Limit Switch function, it is more convenient to use 8.10.5 Limit Switch Mode (LS MOdE oFF/ on).

**Note 1.** Alarms marked with “+” or “++” below are applicable to **6** Communication “5”.

**Note 2.** Alarms marked with “++” below are applicable when both **6** Communication “0” or “2” and **7** Output Option “2” or “3” are selected.

Alarm name to be assigned to digital out port	Abbreviation on LCD	Activated by digital output signal
OFF	OFF	Not activated when alarm occurs.
Temperature High Limit +	TMPH	When the internal temperature exceeds the preset Temperature High Limit.
Temperature Low Limit +	TMPL	When the internal temperature is lower than the preset Temperature Low Limit.
Travel High Limit ++	TVLH	When the valve position exceeds the Travel High Limit towards the 100 % position.
Travel Low Limit ++	TVLL	When the valve position is lower than Travel Low Limit towards the 0 % position.
Deviation Timeout +	DVTO	When actual deviation greater than the preset Deviation persists longer than the preset Deviation Time.
PST Fail +	PSTF	When Partial Stroke Test failed.
Loop Current Low +	LPCL	When Loop input current is below 3.8 mA
Failure +	FAIL	When the events classified as Failure in NE107 signals occur.
Functional Check +	FUNC	When the events classified as Functional Check in NE107 signals occur.
Out of Specification +	OUTS	When the events classified as Out of Specification in NE107 signals occur.
Maintenance required +	MNTR	When the events classified as Maintenance Required in NE107 signals occur.

The assignment of any alarms to NE107 signals is shown in section 8.12.1 Default Alarms Settings. A review of the alarms that occurred the most recently can be done through 8.12.7 View Event Log (EVT LOG).

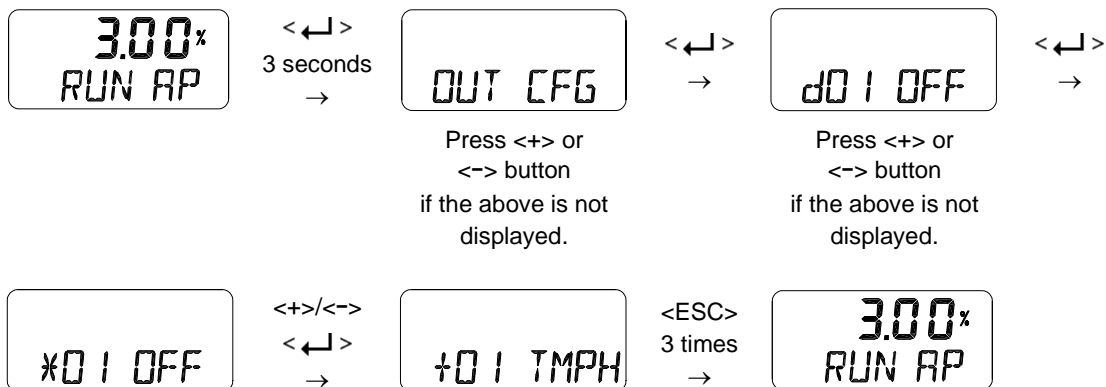

8.10.7 Digital Output Logic (dO1 or dO2 LOGIC HI / Lo)

(This function is available when either **6** Communication “5” or **7** Output Option “2” or “3” of Product code is selected.)

This logic is used to determine the state of Digital Output Switch by High (HI) or Low (Lo) when an event or alarm in synchronization with specific Digital Output switch is triggered. The initial factory setting is HI, which means that when 5 ~ 28 V DC voltage is applied, the output current will be in the range of 2.2 to 14 mA flowing through the digital output switch. Under the setting of Low (Lo), the output current will be less than 1.0 mA when 5 ~ 28 V DC is applied. A resistor limiting the output current is built into the electronic board. When Digital Output switch is used as Limit Switch function, dO1 LOGIC and dO2 LOGIC are assigned to Travel Limit High and Travel Limit Low, respectively.

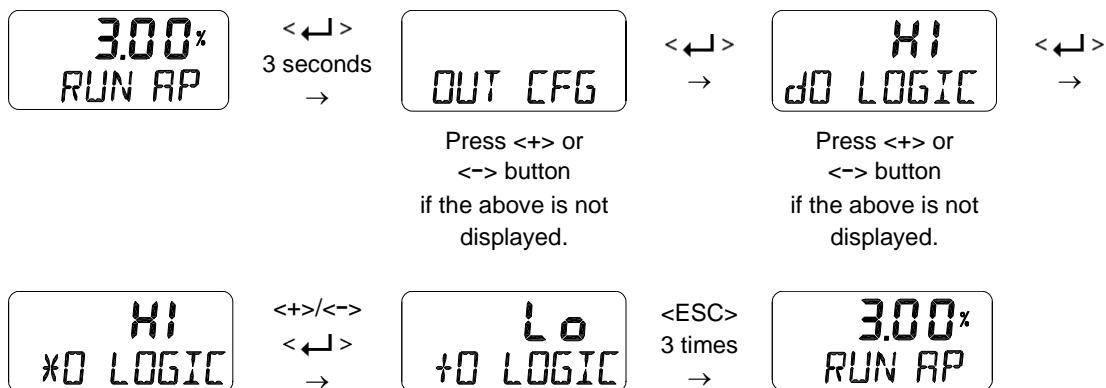

8.10.8 Analog Output Function (AOF OFF / ...)

**((This function is available when both 6 Communication “5” and 7 Output Option “1” or “3” of Product code are selected simultaneously.))**

This is used to output a specific alarm (NAMUR NE43) through the analog output port when triggered. If one of the alarms below occurs, it can be configured so that the analog output is activated. Assign any alarm to one of the four NE107 signals to activate an analog output signal required for any of the listed alarms. The initial factory setting is OFF. Analog output current is selected as 3.6 mA or 21.0 mA by Analog Output Logic (AO LOGIC).

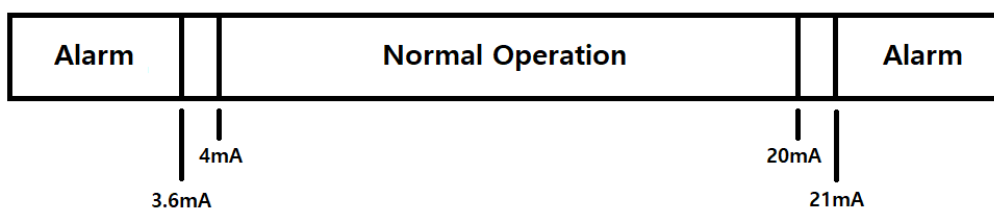

< NAMUR NE43 >

Alarm name to be assigned to digital out port	Abbreviation LCD	on	Activated by analog out signal
OFF	OFF		Not activated when alarm occurs.
Temperature High Limit	TMPH		When the internal temperature exceeds the preset Temperature High Limit.
Temperature Low Limit	TMPL		When the internal temperature is lower than the preset Temperature Low Limit.
Travel High Limit	TVLH		When the valve position exceeds the Travel High Limit towards the 100 % position.
Travel Low Limit	TVLL		When the valve position is lower than Travel Low Limit towards the 0 % position.
Deviation Timeout	dVTO		When actual deviation greater than the preset Deviation persists longer than the preset Deviation Time.
PST Fail	PSTF		When Partial Stroke Test failed.
Loop Current Low	LPCL		When Loop input current is below 3.8 mA
Failure	FAIL		When the events classified as Failure in NE107 signals occur.
Functional Check	FUNC		When the events classified as Functional Check in NE107 signals occur.
Out of Specification	OUTS		When the events classified as Out of Specification in NE107 signals occur.
Maintenance required	MNTR		When the events classified as Maintenance Required in NE107 signals occur.

The assignment of any alarms to NE107 signals is shown in section 8.12.1 Default Alarms Settings. The verification of the alarms that occurred the most recently can be done through 8.12.7 View Event Log (EVT LOG).

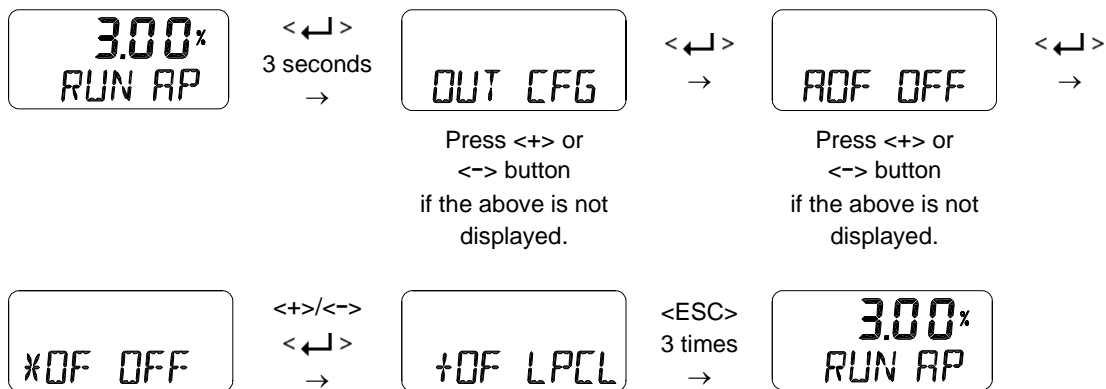

### 8.10.9 Analog Output Logic (AO LOGIC Lo / HI)

(This function is available when both **6** Communication “5” and **7** Output Option “1” or “3” of Product code are selected simultaneously.)

This logic function activates the analog output to High (HI) or Low (Lo). A current of less than 3.6 mA is sourced from the analog output port when the initial factory setting is low (Lo) with an external voltage source applied to the analog output. When the analog output logic is set to HI, more than 21.0 mA is sourced.

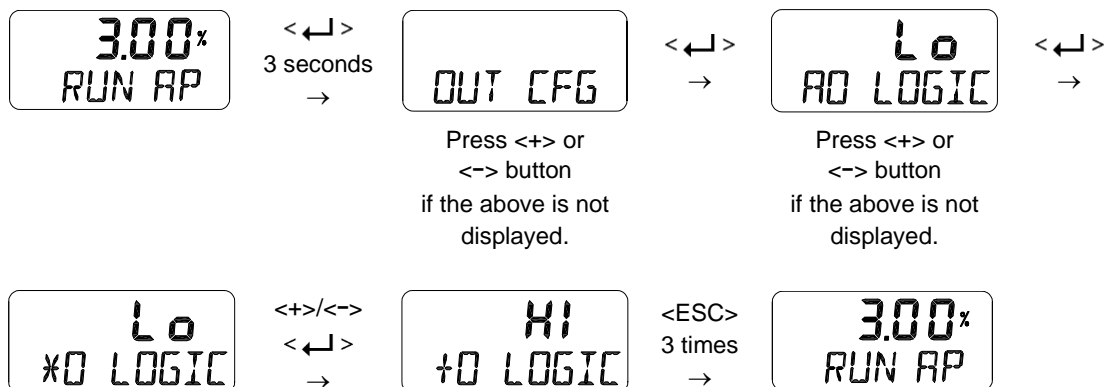

### 8.11 Device Configuration (dEV CFG)

Followings are the values changeable at the dEV CFG Mode.

- 1) Action Setting (ACT REVS / dIR)
- 2) Linear Lever Type (STd / AdT)
- 3) Linear Interpolation (ITP oFF / on)
- 4) Lock of Parameters (Write Protect, W UNLOCK / LOCK)
- 5) Actual Position View Mode (View Mode, VI NORM / REVS)
- 6) Polling address setting (POL AddR 0 ~ 63)
- 7) Factory Reset (dEFAULT oFF / on)
- 8) Positioner Self-Test (SELFTEST)

#### 8.11.1 Action Setting (ACT REVS / dIR)

Reverse Action (REVS) or Direct Action (dIR) are automatically set by performing "AUTO 2" within the Auto Calibration function. However, this function is used when the user requires to change ACT REVS or ACT dIR to other action. Changing the action from Reverse Action (REVS) to Direct Action (dIR) or Direct Action (dIR) to Reverse Action (REVS) will also change the Signal Direction (SIG), Position Transmitter Direction (PTM), HART Feedback Direction (HT) and View Mode (VI).

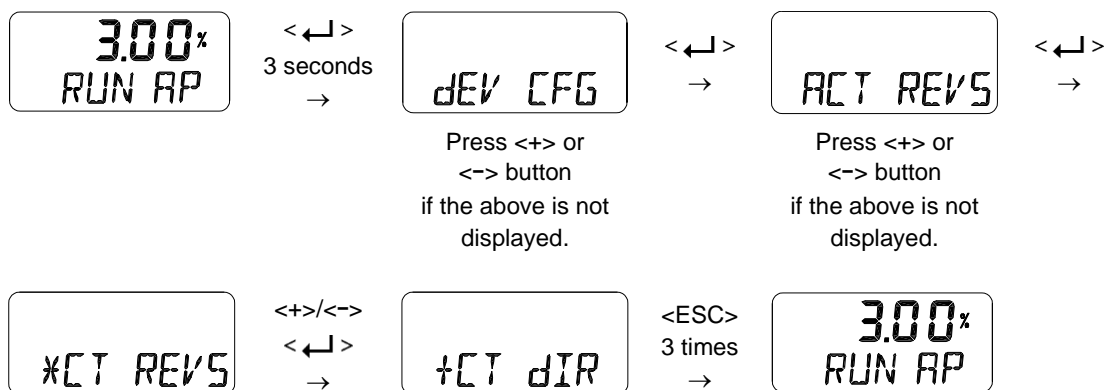

#### 8.11.2 Linear Lever Type (LEVT STd / AdT)

Displays or changes current linear lever type into standard type or adapter type. If the Lever type mode is set correctly, the accuracy will be worse at ITP ON than at ITP OFF.

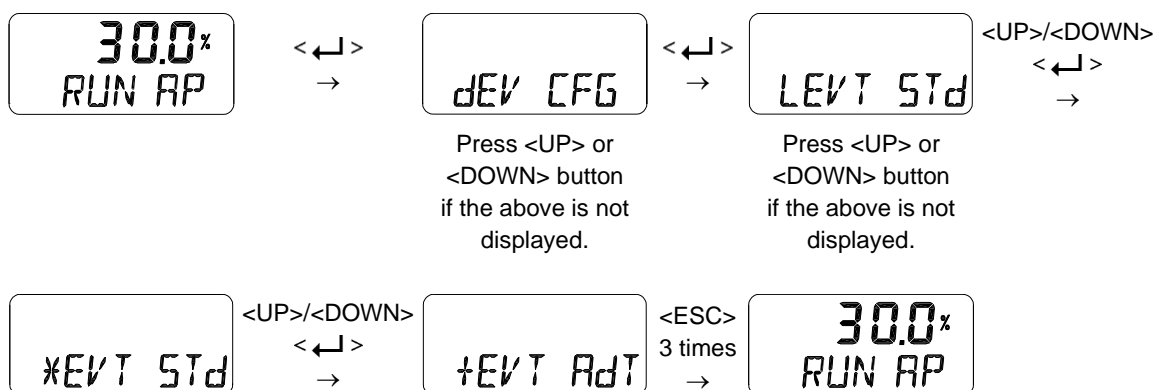

### 8.11.3 Linear Interpolation (ITP OFF / on)

ITP is used to compensate the linear motion of the actuator into rotary motion of the feedback lever. Following Auto Calibration, the ITP mode is set automatically to “on” when the angle range of the feedback lever is greater than 20 °, but it is set to oFF when this angle is less than 20 ° or rotary positioner is used.

The settings below are the process of manually changing the “ITP oFF” to the “ITP on”.

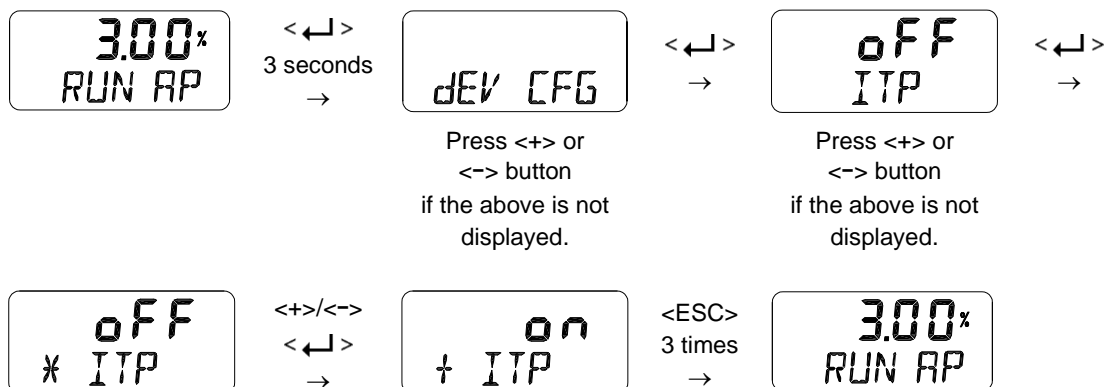

### 8.11.4 Lock of Parameters (Write Protect, W UNLOCK / LOCK)

This function is used to set (LOCK) or disable (UNLOCK) the lock for the parameters. Used to prevent the stored parameters from being changed.

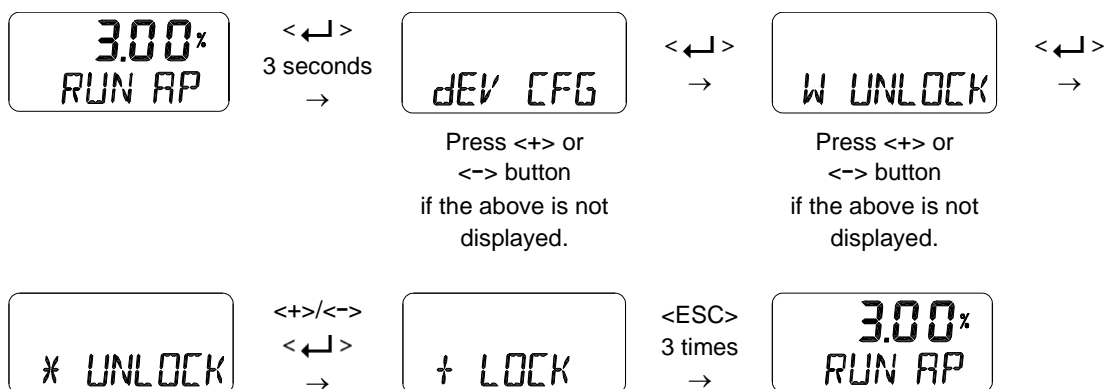



8.11.5 Actual Position View Mode (View Mode, VI NORM / REVS)

This function is used to set the "RUN AP" value on the LCD to be displayed as direct (NORM) or reversely (REVS) as the actual position of the valve.

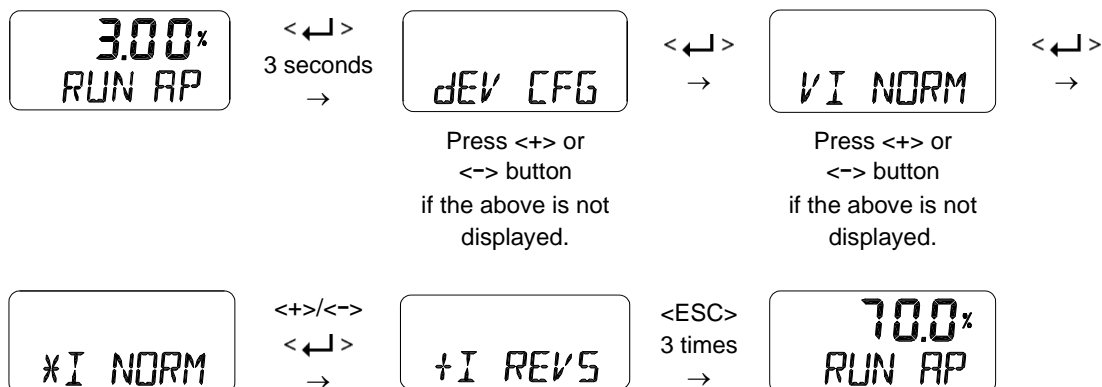

8.11.6 Polling address setting (POL Addr)

This function is used to set the address value of the positioner on HART(Highway Addressable Remote Transducer) communication. The value from 0 to 63 could be set and default is 0.

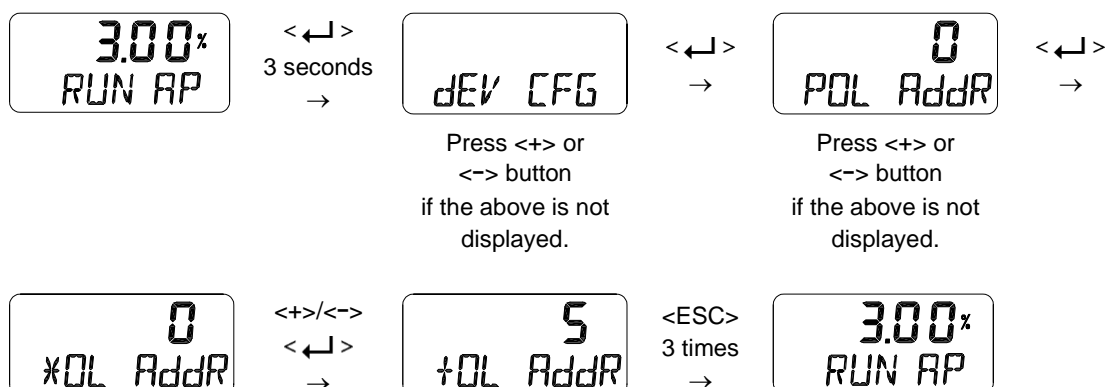

8.11.7 Factory Reset (dEFAULT oFF / on)

This function initializes all parameters stored in the positioner to initial factory setting. In the dEFAULT mode, press the Enter button to enables ON/OFF setting and then pressing Enter button for approximately 3 seconds changes the dEFAULT mode from oFF to "on". Additional pressing of Enter button resets all parameters to initial factory state.



**Pay attention when using this mode as all the parameter values will be changed to the factory settings.**

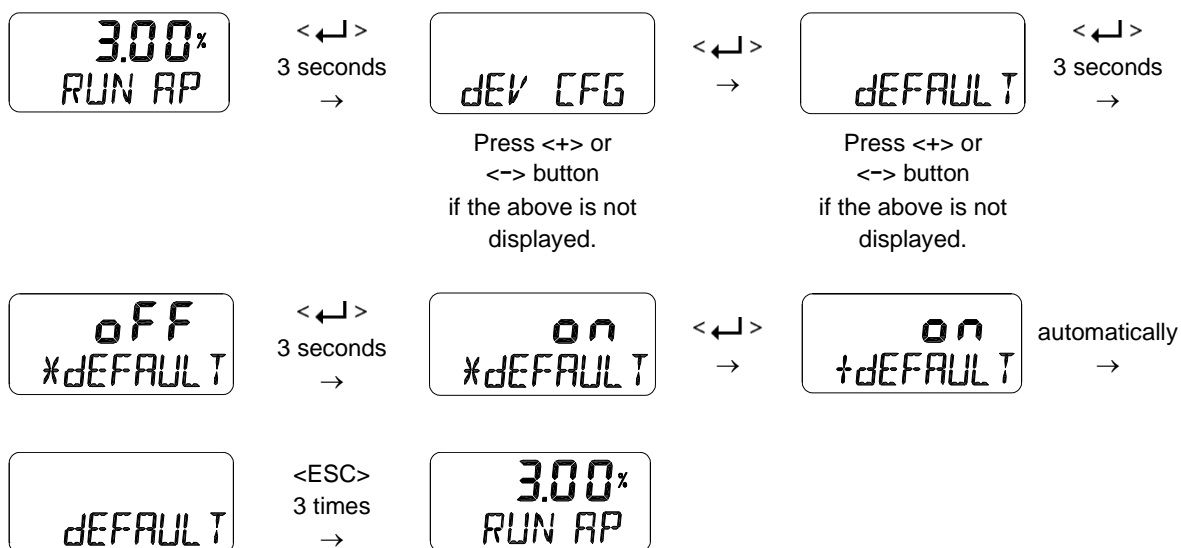

8.11.8 Positioner Self-Test (SELFTEST)

This function is used to diagnose the operation of the memory (RAM or NVM) inside the positioner. If no error is found during SELFTEST, the SELFTEST menu is displayed after FINISH is displayed, and if abnormalities are detected, the message "SEt / NVMW" is displayed.

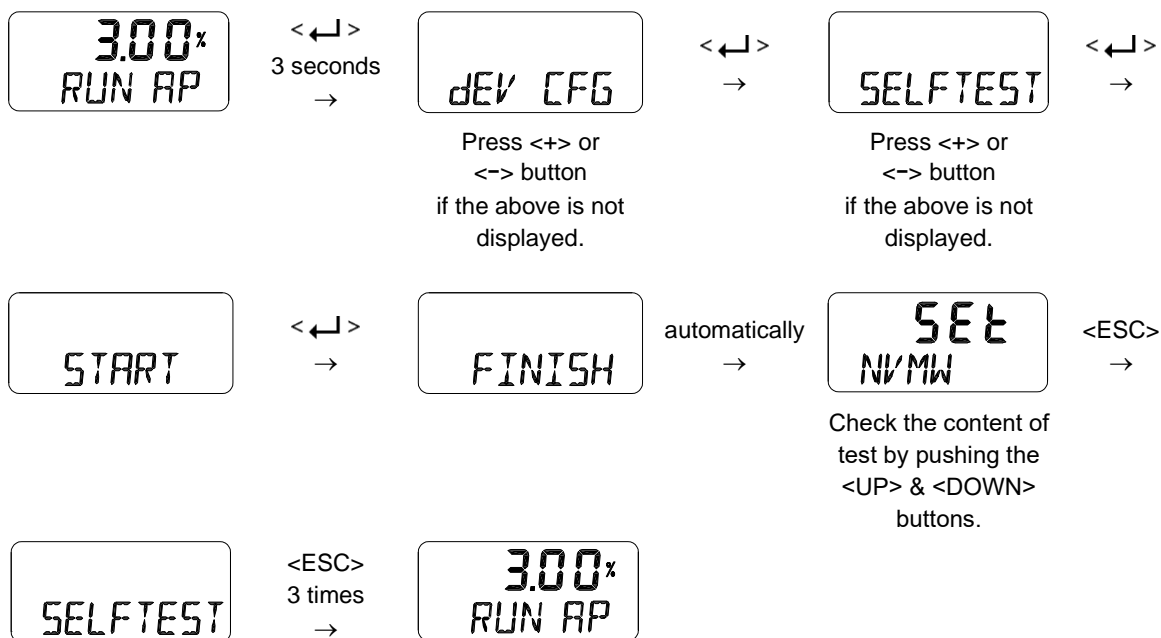

# Diagnostic message



If the abbreviation displayed at the top line is "Set", it means the event has been created, and if it is "CLr", the message has been cleared. NVMW at the bottom is an alarm message that has occurred. See "8.15 Status and Alarm Code" for alarm details.

## 8.12 Diagnosis Mode (dIAGNd)

Followings are the values changeable at the dIAGNO Mode.

- 1) Default Alarm Settings (Some functions are applicable to 6 Communication only “5” of Product Code)
- 2) Process Status (PS)
- 3) Device Status (dS)
- 4) View Monitoring Counts (VI CNTS)
- 5) Diagnostic Limit Configuration (LIMT CFG)
- 6) Reset Alarm Status (RST ALRM)
- 7) View Event Log (EVT LOG)
- 8) Partial Stroke Test Record (View PST Result Record, PST RSLT)
- 9) PST Configuration (PST CFG)
- 10) Run PST (PST NOW)
- 11) Periodic PST Test (PST Schedule, PST SCHd)

### 8.12.1 Default Alarm Settings

The table below shows the initial values set at factory for handling the positioner status or associated process conditions. To trigger any alarm automatically when a specific event occurs, the corresponding alarm needs to be set to “Enable”. Each status or alarm is also set to either Failure, Out of Specification, Maintenance Required, or Functional Check depending on the classification of the NE107 signal, so that the corresponding NE107 symbol is displayed when a preset alarm occurs. This setting can be reassigned to the one of NE107 signals, depending on the operator's decision. As shown in the table below, the status / alarms that can be manually reset are Auto Calibration Running, Diagnosis Running, Critical NVM Fail, Non-Critical NVM Fail, PST Fail and Auto Calibration Fail. The activation of each status / alarm and the classification of NE107 signals can be set through HART communication, and the five alarms below can be even activated using the LCD screen and button.

- Travel High Limit, Travel Low Limit, Temperature High Limit, Temperature Low Limit and Deviation Timeout

**Note 1. Any Status or Alarm marked with + below is applicable to 6 Communication “5” of Product code**

**Note 2. NE107 signal is not reconfigurable when 6 Communication “0” or “2” of Product code is selected.**





**Note 3. The parameters Deviation Time and Deviation Deadband to trigger Deviation Timeout Alarm are not changeable when 6 communication 0 or 2 of Product Code is selected.**

Status / Alarm	Default setting		Default NE107 signal	Resettable manually? when alarm occurred?
	6 Communication			
	0 or 2	5		
Local Operation Active	<b>Enable</b>	<b>Enable</b>	Functional Check	No
Auto Calibration Running	<b>Enable</b>	<b>Enable</b>	Functional Check	Yes
PST Running	<b>Enable</b>	<b>Enable</b>	Functional Check	No
Diagnosis Running +	<b>Enable</b>	<b>Enable</b>	Functional Check	Yes
Position Sensor High Limit	<b>Enable</b>	Disable	Out of Specification	No
Position Sensor Low Limit	<b>Enable</b>	Disable	Out of Specification	No
Critical NVM Fail	<b>Enable</b>	<b>Enable</b>	Failure (Reserved)	Yes
Non Critical NVM Fail	<b>Enable</b>	Disable	Failure	Yes
Cycle Count Limit +	Disable	Disable	Maintenance Required	No
Travel Accumulate Limit +	Disable	Disable	Maintenance Required	No
Operating Count Limit +	Disable	Disable	Maintenance Required	No
Temperature High Limit +	Disable	Disable	Out of Specification	No
Temperature Low Limit +	Disable	Disable	Out of Specification	No
Travel High Limit	Disable	Disable	Out of Specification	No
Travel Low Limit	Disable	Disable	Out of Specification	No
Deviation Timeout +	<b>Enable</b>	<b>Enable</b>	Out of Specification	No
PST Fail	<b>Enable</b>	<b>Enable</b>	Failure	Yes
Temperature Sensor Fail Reserved.	<b>Enable</b>	Disable	Failure	No
Position Sensor Fail Reserved.	<b>Enable</b>	<b>Enable</b>	Failure	No
Abnormal Drive Signal +	<b>Enable</b>	Disable	Out of Specificaion	No
Travel Cutoff High Limit	<b>Enable</b>	Disable	Out of Specification	No
Travel Cutoff Low Limit	<b>Enable</b>	Disable	Out of Specification	No
Not Calibrated	<b>Enable</b>	Disable	Maintenance Required	No
Auto Calibration Fail	<b>Enable</b>	<b>Enable</b>	Maintenance Required	Yes
Zero Point Drift +	Disable	Disable	Maintenance Required	No
End Point Drift +	Disable	Disable	Maintenance Required	No
Communication Error Limit +	Disable	Disable	Out of Specification	No
Full Close Count Limit +	Disable	Disable	Maintenance Required	No
Full Open Count Limit +	Disable	Disable	Maintenance Required	No
Loop Current High Limit +	Disable	Disable	Out of Specificaion	No
Loop current Low Limit	<b>Enable</b>	<b>Enable</b>	Failure	No

Status / Alarm	Default setting		Default NE107 signal	Resettable manually? when alarm occurred?
	6 Communication			
	0 or 2	5		
DI Status Change +	Disable	<b>Enable</b>	Not defined	No
DO1 Status Change +	Disable	<b>Enable</b>	Not defined	No
DO2 Status Change +	Disable	<b>Enable</b>	Not defined	No
Diagnosis Fail +	Disable	Disable	Failure	No

8.12.2 Process Status (PS)

The status of the current process is indicated as GOOd, NE107 symbol, and abbreviation for alarm.

NE107 symbols	Abbreviation	Function
None	PS GOOd	Good
	PS FAIL	Failure
	PS FUNC	Functional Check
	PS OUTS	Out of Specification
	PS MNTR	Maintenance Required



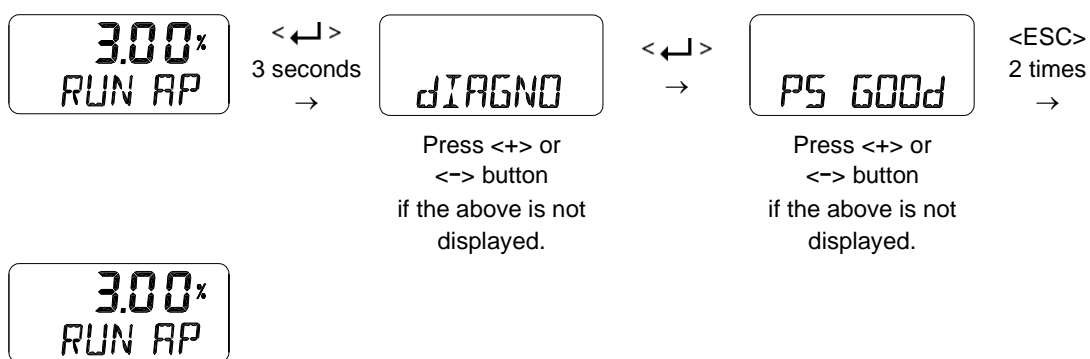

At the factory, each alarm is assigned to one of the four NE107 signals and can be reassigned as needed. Reassignment of NE107 signals to process alarms shall be made using HART communication. The table below shows the type of the process status or alarm and its abbreviations. See 8.15 Status and Alarm Code for the details of each alarm.

Process Alarm	Abbreviation
Cycle Count Limit	CYCC
Travel Accumulator Limit	TVLA
Operating Count Limit	OPRC
Temperature High Limit	TMPH
Temperature Low Limit	TMPL
Travel High Limit	TVLH
Travel Low Limit	TVLL
Deviation Timeout	dVTO
Travel Cutoff High Limit	TVCH
Travel Cutoff Low Limit	TVCL
Zero Point Drift	ZPDR
End Point Drift	EPDR
Full Close Count Limit	FCLC
Full Open Count Limit	FOPC
Loop Current High Limit	LPCH
Loop Current Low Limit	LPCL



### 8.12.3 Device Status (dS)

The status of the current device is indicated as GOOD, NE107 symbol, and abbreviation for alarm.

NE107 symbols	Abbreviation	Function
None	dS GOOD	Good
	dS FAIL	Failure
	dS FUNC	Functional Check
	dS OUTS	Out of Specification
	dS MNTR	Maintenance Required

Reassignment of NE107 signals to device alarms shall be made using HART communication. The table below shows the type of the device status or alarm and its abbreviations. See 8.15 Status and Alarm Code for the details of each alarm.

Device Alarm	Abbreviation
Loop Operation Active	LOPA
Auto Calibration Running	CALR
PST Running	PSTR
Diagnosis Running	dIGR
Position Sensor High Limit	PSNH
Position Sensor Low Limit	PSNL
Critical NVM Fail	NVMF
Non-Critical NVM Fail	NVMW
Abnormal Drive Signal	AbdS
Not Calibrated	NCAL
Auto Calibration Fail	CALF
Communication Error Limit	COMM
DI 1 Status	dI1S
DO 1 Status	dO1S
DO 2 Status	dO2S
Diagnosis Fail	dIGF
PST Fail	PSTF

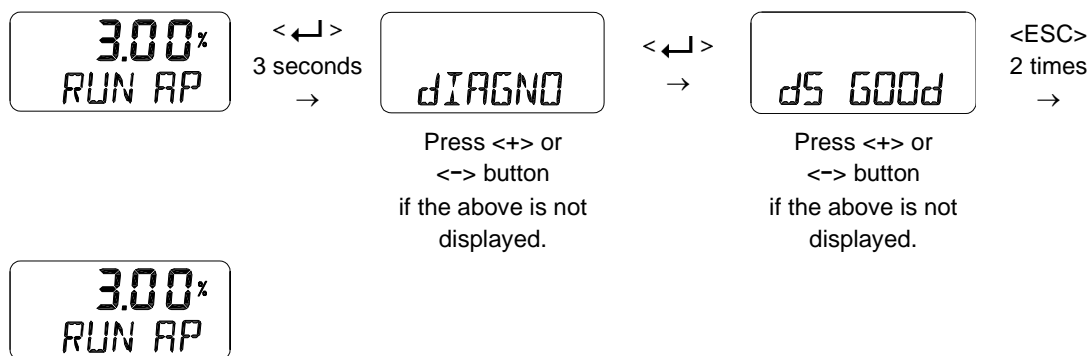



8.12.4 View Monitoring Counts (VI CNTS)

It is used to view the accumulated data information for valve movement up to now.

Counter Name	Abbreviation [unit]	Function
Cycle Count	CYCL CNT	The accumulated number of times the valve has changed its direction. It is accumulated only when the valve change direction while Cycle Count Deadband is exceeded.
Travel Accumulator	TVL ACUM [%]	The total valve travel accumulated whenever Travel Accumulator Deadband is exceeded.
Operating Count	OPER CNT	Total number of input change applied to I/P converter.
Fully Open Count	FOP CNT	The accumulated number of times the valve has been fully open.
Fully Closed Count	FCL CNT	The accumulated number of times the valve has been fully closed.

The upper limit for the five counters can be set so that an alarm is triggered if the accumulated counter value exceeds this limit. Other parameters related to the counters, such as Cycle Count Deadband, Travel Accumulator Deadband or Upper Limits for the counters can be only set through HART using DD or DTM.

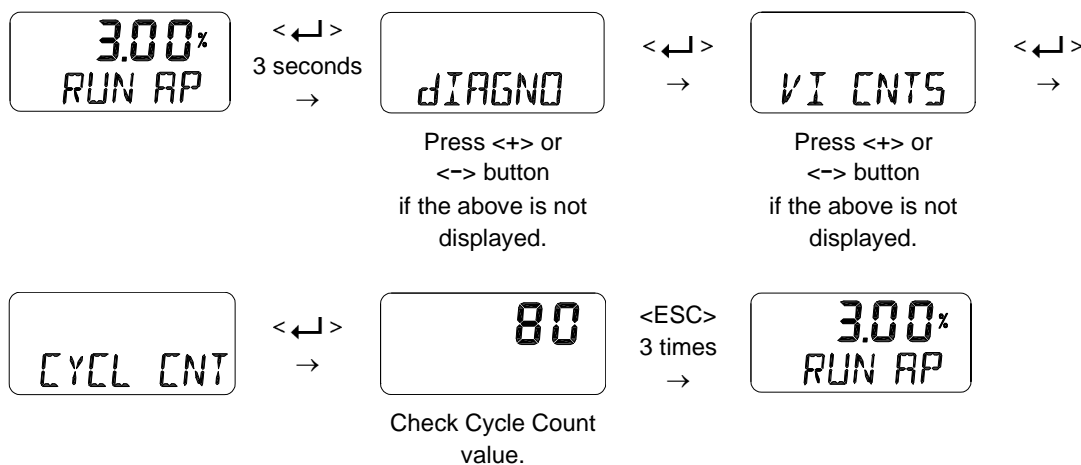

8.12.5 Diagnostic Limit Configuration (LIMT CFG)

This configuration is used to set the upper or lower limit that is generated by the Travel High Limit Alarm, Travel Low Limit Alarm, Temperature High Limit Alarm, Temperature Low Limit Alarm, and Deviation Timeout Alarm. Even if this condition is met, the corresponding alarm will not be triggered if the alarm(s) is not enabled.

Upper / Lower Limit or Enable	Abbreviation [unit]	Description
Travel High Limit	TVL HI [%]	Alarm is triggered if the valve stroke exceeds TVL HI. The initial factory setting is 100%.
Travel Low Limit	TVL LO [%]	Alarm is triggered if the valve stork is lower than TVL LO. The initial factory setting is 0 %.
Temperature High Limit	TEMP HI [°C]	Alarm is triggered if the internal temperature exceeds TEMP HI. The initial factory setting is +85 °C.
Temperature Low Limit	TEMP LO [°C]	Alarm is triggered if the internal temperature is lower than TEMP LO. The initial factory setting is -30°C.
Deviation Time	dV TIME [sec]	Alarm is triggered if actual deviation RUN dV larger than the preset "dv db" persists longer than the preset "dV TIME". The initial factory setting is 60 sec and 5 %.
Deviation Deadband	dV db [%]	
Travel High Limit Alarm Enable	AL TVLH	These are used to set "on" or "off" for each alarm. When set to off, the alarm does not occur even if the conditions are met. All the initial factory settings are off.
Travel Low Limit Alarm Enable	AL TVLL	
Temperature High Limit Alarm Enable	AL TMPH	
Temperature Low Limit Alarm Enable	AL TMPL	
Deviation Timeout Alarm Enable	AL dVTO	

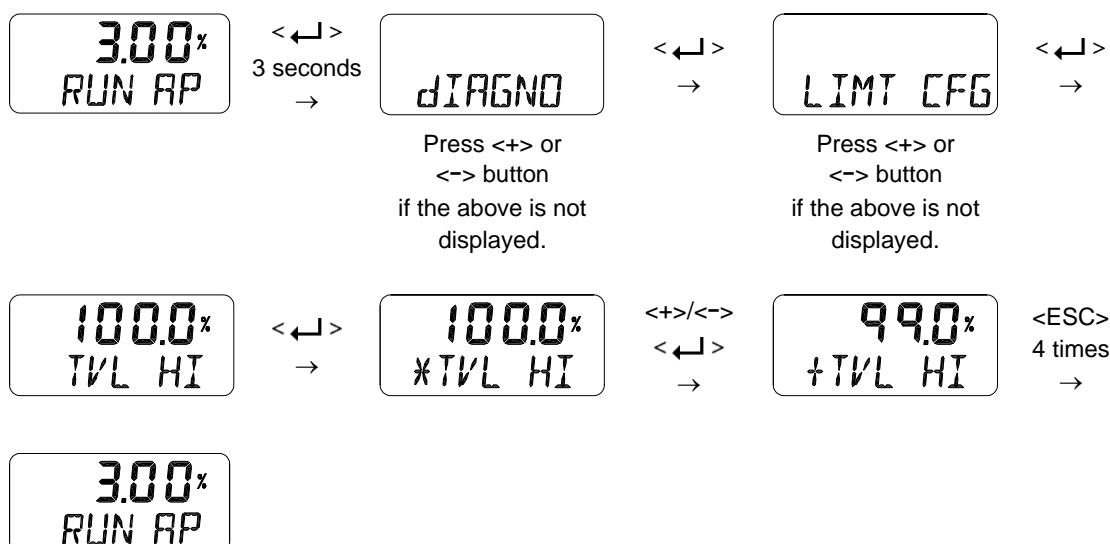

8.12.6 Reset Alarm Status (RST ALRM off / on)

The alarm is automatically released when the cause of the alarm is removed. For example, if a high-temperature alarm is created, the alarm is automatically released when internal temperature drops below the Temperature High Limit. However, if the Partial Stroke Test fails or Auto Calibration fails, use this function to release the alarm.

Below is an alarm list that can be released using the RST ALRM function.

- 1) Auto Calibration Running
- 2) Diagnosis Running
- 3) Critical NVM Fail
- 4) Non-Critical NVM Fail
- 5) PST Fail
- 6) Auto Calibration Fail

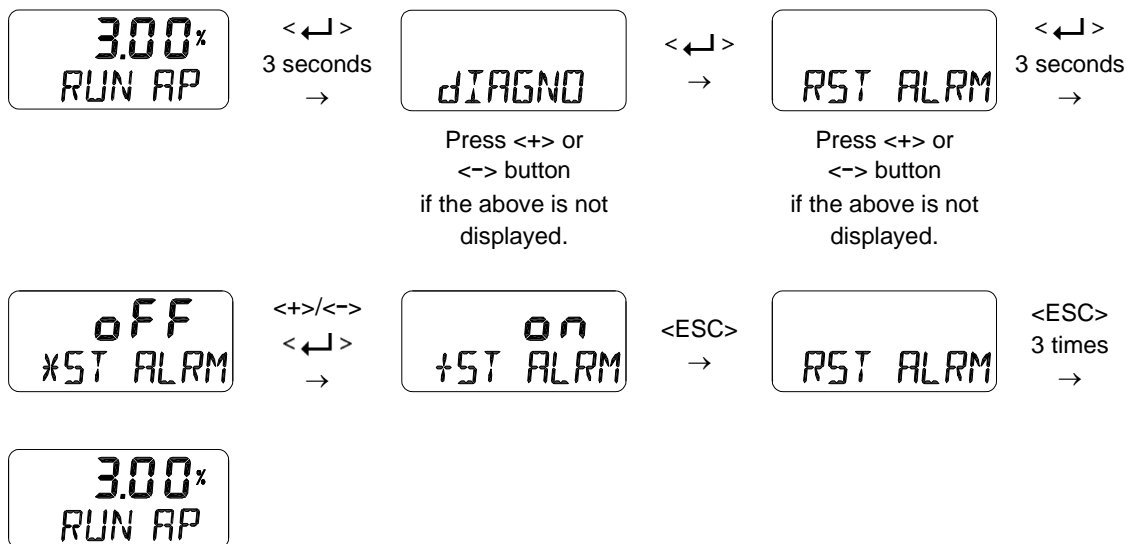

### 8.12.7 View Event Log (EVT LOG)

This is used to show the 20 most recent events that occurred in operation. Record 0 is the most recent of the 20 events and Record 19 is the oldest event. The event detail shows the time when the event occurred (EVT TIME) as well as the content of the event (EVT INFO). See 8.15 Status and Alarm Codes for an abbreviation and description of the event details.

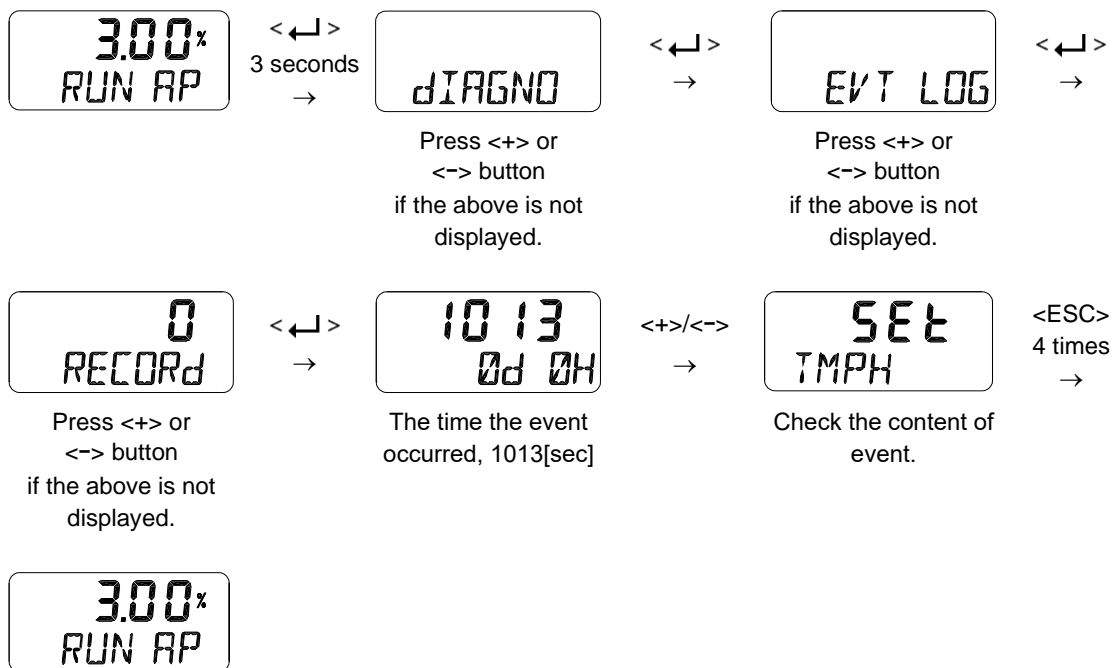

#### # Event Message Description



The "SET" on the upper section of screen shows that a specific event has occurred, while the "CLR" means that the event has been removed. The "TMPH" displayed on the bottom section indicates an abbreviation for the alarm.

8.12.8 Partial Stroke Test Record (View PST Result Record, PST RSLT)

This is used to show information about the 10 most recent Partial Stroke Tests performed. Record 1 is the most recent of the 10 PST histories, and Record 10 is the result of the oldest PST operation. The response time (RT), response code (RC), and dead time (dT) after the PST operation are also shown. Response time represents the time to reach the target position from the PST start, and deadtime indicates the time from the start of the PST command to the moment the valve starts to move. The table below describes the response codes.

Name of RC	Response Code (RC)		Description
Pass	PASS	1	Pass
Out Of Tolerance	OOT	2	Out of Tolerance : When PST is executed, the AP (actual position) is out of PST tolerance compared to the PST start position value.
PST Time Out	PSTO	3	Time Out : Aborted if the AP fails to move to the Target Position within PST Limit Time during PST execution.
Abort	AbOT	4	Abort, but reserved
Hunting	HUNT	5	Hunting occurs during the test.
Abnormal Shutdown	AbSd	6	Abnormal Shutdown : An unexpected problem occurred during the test.
Loop Current Low	LPCL	256	PST execution is stopped due to a change in the input signal (0.8 mA (5%) or more).
Stop By Digital Input	STdI	512	Stopped by Digital Input Function (dIF)

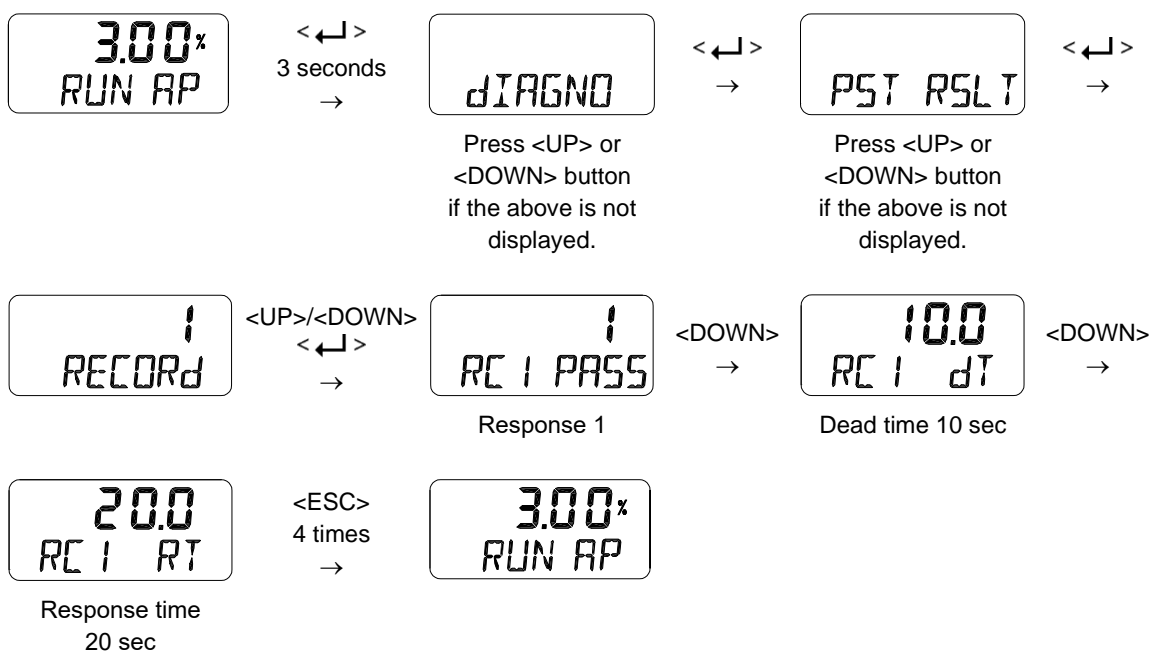

8.12.9 PST Configuration (PST CFG)

Parameter names	Abbreviation [unit]	Description
PST Interval	INTERVAL [days]	Sets time interval PST is triggered. Initial factory setting is 365 days.
PST Start Position	START PO [%]	Sets the start position to launch PST. Initial factory setting is 100 %.
PST Tolerance	TOL [%]	The allowable tolerance for the start position. PST Failure alarm is triggered as Out of Tolerance(OOT) when actual position exceeds the tolerance. Initial setting is 5 %.
PST Target Position	TARGET [%]	Target position. Initial factory setting is 90 %.
PST Hold Time	HOLD TM [sec]	Sets hold time after target position ( $\pm 2$ %) is reached. Initial factory setting is 5 sec.
PST Limit Time	LIMIT TM [sec]	PST Failure alarm is triggered as Limit Time Over (LTO) when target position is not reached within LIMT TM after starting PST. Initial factory setting is 10 sec.
PST Ramp Up Rate	RAMP UP [%/sec]	Sets ramp rate when the valve moves from the target position to the start position. Initial factory setting is oFF.
PST Ramp Down Rate	RAMP dN [%/sec]	Sets ramp rate when the valve moves from the start position to the target position. Initial factory setting is oFF.
Remaing PST Time	NEXT PST [days.hrs]	Based on the current time, the remaining time to start PST is displayed by Days and Time.

Graph below shows PST target position (TP) and actual position (AP) when applying PST Start Position 100 %, Target Position 90 %, Hold Time 10 sec, PST Ramp up Rate 0.5 %/sec, PST Ramp down Rate 0.5 %/sec.



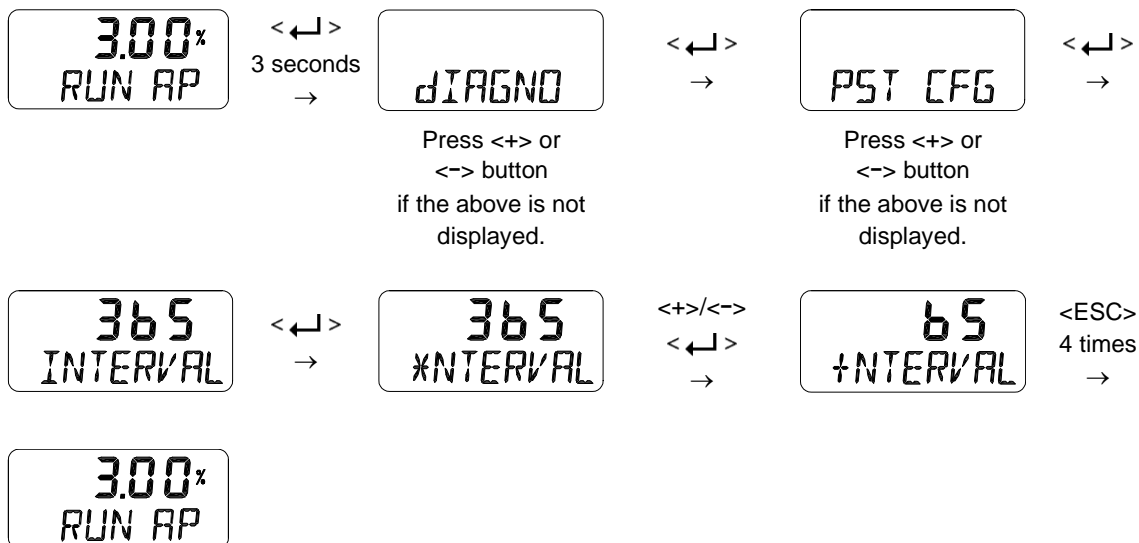

### 8.12.10 Run PST (PST NOW)

PST NOW is used to perform Partial Stroke Test promptly in accordance with the conditions set in 8.12.9.

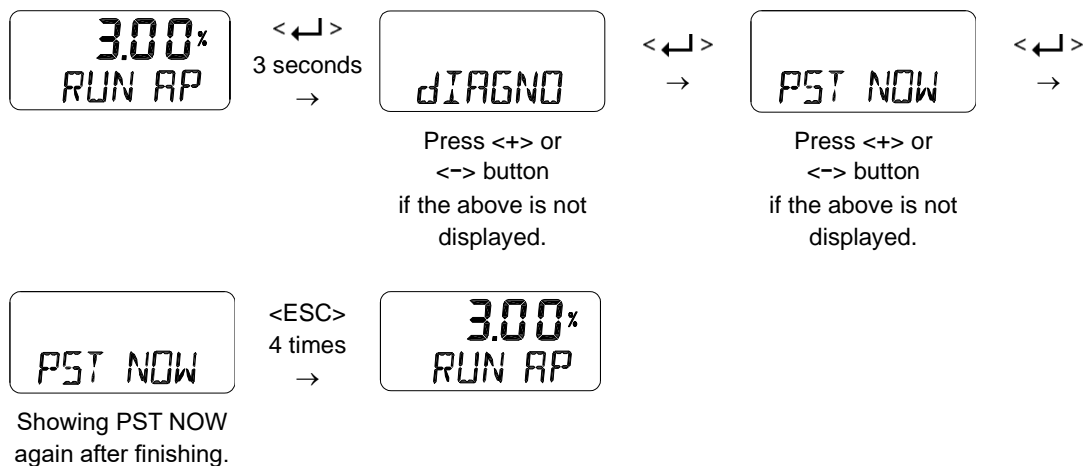

8.12.11 Periodic PST Test (PST Schedule, PST SCHd OFF / on)

When PST SCHd is set to ON, the Partial Stroke Test is executed regularly under the conditions set in 8.12.9 above. For example, PST is performed every 365 days when PST Interval is set to 365 days. The initial factory setting is OFF.

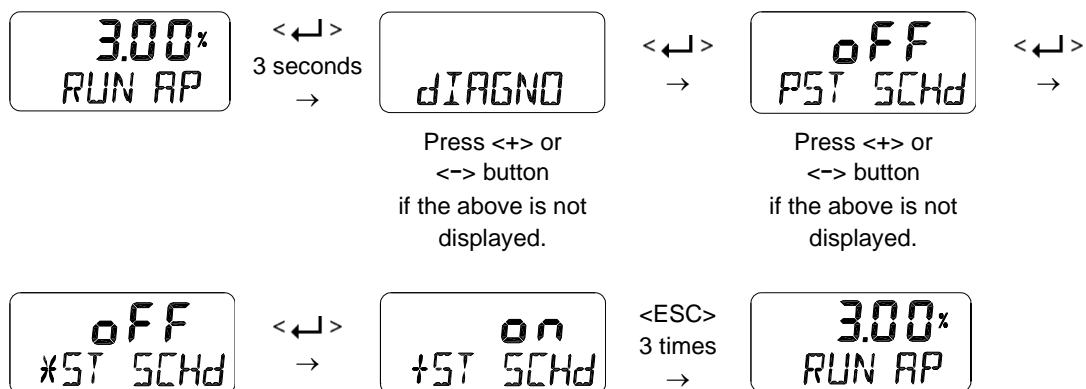

8.13 Position information (INFO)

The diverse Positioner information is provided in the INFO Mode.

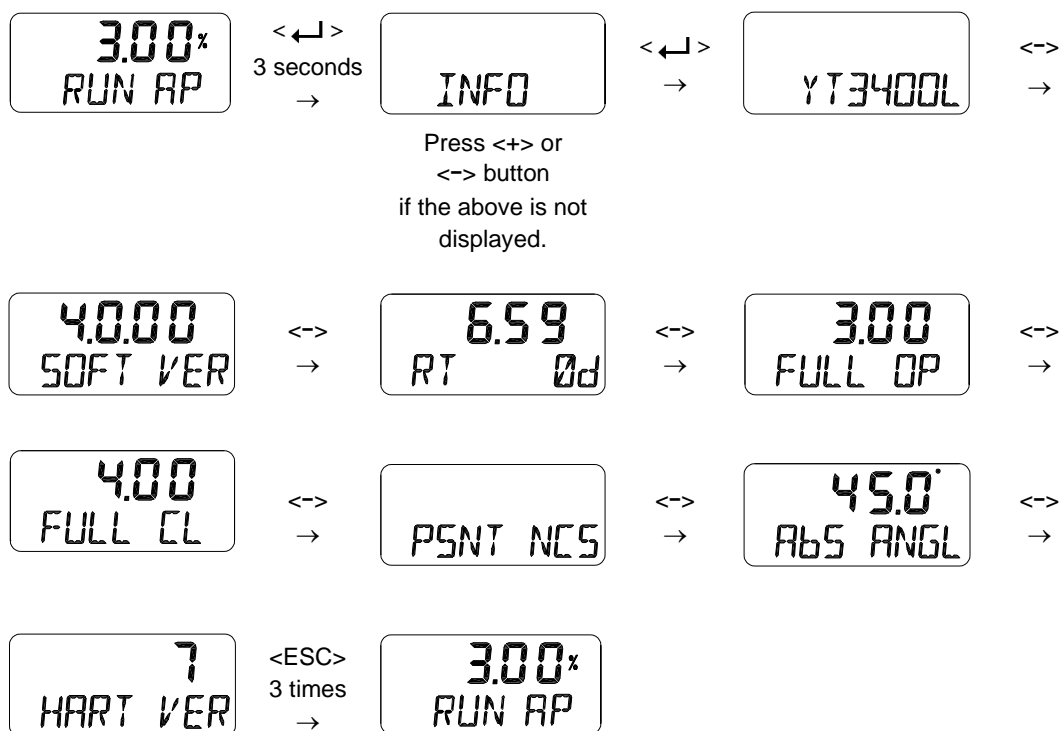



LCD display	Description
<b>YT3400L</b>	Model Name
<b>4.0.00 SOFT VER / 2022JA31</b>	Software Version [SOFT VER] "4.0.00" Software Input date : "2022-01(JA)-31" (January JA, February FB, March MR, April AR, May MY, June JN, July JL, August AG, September SP, October OT, November NV, December DC) At SOFT VER status if <← > button is pressed, the date will be displayed and then if <← > button is pressed again, SOFT VER is displayed again.
<b>4.18 RT      0d</b>	Run Time [RT] Total usage time of the product Upper "4.18" indicates 4 hours and 18 minutes. Lower "0d" indicates days used. Interval to store time is one hour.
<b>3.12 FULL OP</b>	Upward Full Stroke Time [FULL OP] This value is stored automatically after executing AUTO 2 calibration, and indicates the time in seconds it takes for the valve to fully open from fully closed.
<b>2.97 FULL CL</b>	Downward Full Stroke Time [FULL CL] This value is stored automatically after executing AUTO 2 calibration, and indicates the time in seconds it takes for the valve to fully closed from fully open.
<b>PSNT NCS</b>	Position Sensor Type [PSNT] Potentiometer [PTN] Non-Contact Sensor [NCS]
<b>AbS ANGL</b>	Absolute Position in Angle [ABS ANGL].
<b>HART VER</b>	HART Protocol Revision [HART VER]

8.14 Error codes during automatic calibration

There may be an error during the automatic calibration in case of irregularity.

- Error code : indicated if the positioner is out of control, malfunctions or becomes imprecise.
- When the error is detected, auto calibration is aborted and message is indicated immediately on LCD display.

Error code		Error content and cause	Action
CHK AIR	-7	➤ Indicated when the valve is not moving in "Full Open" direction during auto calibration.	➤ Check if pneumatic pressure is being supplied normally to the positioner.
	-9	➤ Indicated when the valve is not moving in "Full Close" direction during auto calibration.	
	-10	➤ Indicated when there is no response in torque motor.	
	-12	➤ Indicated when oscillation happens in steady state during SCAN 1 phase of auto calibration.	➤ Check for leakage from output port of the positioner and related to piping line.
CHK LINK	-8	➤ Indicated when the movable range of the Feedback lever is too narrow.	➤ Move and re-install the positioner to stem of actuator in order to make the angle use of the feedback lever larger than current use angle.

8.15 Status and Alarm Code

Refer to the table below to check the status and alarm codes that can be displayed on LCD screen or HART monitor, and then take the appropriate action.

**Note 1. Any Status or Alarm marked with + below is applicable to 6 Communication “5” of Product code.**

**Note 2. Any alarm or status is newly assignable to one of NE107 signals marked with ++ below as far as 6 Communication “5” of Product code is selected. In other options, it is not newly assignable.**

Alarm Code	Abbreviation	Status / Alarm name	Description or proposed actions
0	LOPA	Local Operating Active	It indicates the positioner is being operated by manual operation.
1	CALR	Auto Calibration Running	It is active when auto-calibration is in progress.
2	PSTR	PST Running	It is active when Partial Stroke Test is in progress.
3	DIGR +	Diagnostics Running	It is active when diagnosis test such as Step Response Test, Stroke Time Test, and Trace Test is in progress.
4	PSNH	Position Sensor Hi Limit	Position sensor is out of range. Check the installed state if it happened during operation.
5	PSNL	Position Sensor Lo Limit	
6	NVMF	Critical NVM Defect	It is active if there is a failure associated with NVM (Nonvolatile Memory). Initialize the positioner using Default function and then AUTO 2 calibration. If it is repeated, replace the electronics board by contacting the manufacturer or manufacturer’s representative.
7	NVMW	Non-Critical NVM Defect	
8	CYCC +	Cycle Count Limit	It is active if the accumulated cycle counter exceeds Cycle Count Limit. Check the condition of the valve and then determine if it is replaced or not. If there is no problem with the valve, increase the Cycle Count Limit.
9	TVLA +	Travel Accumulator Limit	It is active if the travel accumulator exceeds Travel Accumulator Limit. Check the condition of the valve and then determine if it is replaced or not. If there is no problem with the valve, increase the Travel Accumulator Limit.
10	OPRC +	Operating Count Limit	It is active if the number of operations for I/P converter exceeds has exceeded Operating Count Limit. Determine if the setting is appropriate or the I/P converter is replaced or not.

Alarm Code	Abbreviation	Status / Alarm name	Description or proposed actions
11	TMPH +	Temperature Hi Limit	It is active if internal temperature exceeds Temperature Hi Limit. If the set temperature exceeds the maximum temperature allowed by the product, the product may not operate if the ambient temperature around the positioner is not lowered.
12	TMPL +	Temperature Lo Limit	It is active if internal temperature is lower than Temperature Lo Limit. If the set temperature is lower than the minimum temperature allowed by the product, the product may not operate if the ambient temperature around the positioner is not raised.
13	TVLH	Travel Hi Limit	It is active when the travel exceeds Travel Hi Limit.
14	TVLL	Travel Lo Limit	It is active when the travel falls below Travel Lo Limit.
15	dVTO +	Deviation Time Out	<p>➤ 0 or 2 of <span style="border: 1px solid black; padding: 0 2px;">6</span> Communication :</p> <p>The deviation between the target location and the actual location has been out of 5% for more than 60 seconds. The above 5% and 60 seconds cannot be changed and are fixed values.</p> <p>Check for problems such as friction of the valve/actuator, leakage of pneumatic pressure, lack of supply pressure, etc.</p> <p>➤ 5 of <span style="border: 1px solid black; padding: 0 2px;">6</span> Communication :</p> <p>The deviation between the target location and the actual location is outside the set deviation and lasts longer than the set deviation time. Please check if the value you set is appropriate. Check for problems such as friction of the valve/actuator, leakage of pneumatic pressure, lack of supply pressure, etc.</p>
16	PSTF	PST Failure	It is active when Partial Stroke Test has failed. Remove the cause of the failure after checking the response code of the PST.
17	TSNF	Temperature Sensor Defect	It is active when internal temperature sensor has failed. If it is repeated, replace the electronics board by contacting the manufacturer or manufacturer's representative.
18	PSNF	Position Sensor Defect	It is active if there is a problem with the position feedback sensor inside the positioner. If it is repeated, replace the electronics board by contacting the manufacturer or manufacturer's representative.
19	ABdS +	Abnormal Drive Signal	It is active if there is a problem with I/P converter. If it is repeated, replace the electronics board by contacting the manufacturer or manufacturer's representative.

Alarm Code	Abbreviation	Status / Alarm name	Description or proposed actions
23	TVCH	Travel Cutoff Hi Limit	It is active when the travel exceeds the available high stroke of the valve/actuator. The available stroke is already set during auto calibration. The event is not created when Tight Shut Open is used. Aging of the valve / actuator assembly or problem in the positioner sensor.
24	TVCL	Travel Cutoff Lo Limit	It is active when the travel is below the available low stroke of the valve/actuator. The available stroke is already set during auto calibration process. The event is not created when Tight Shut Close is used. Aging of the valve / actuator assembly or problem in the positioner sensor.
28	NCAL	Not Calibrated	It is active when auto-calibration has not done after installation. Perform AUTO 2 calibration after checking if the installed state is good.
29	CALF	Auto Calibration Failure	It is active when auto-calibration has failed. Retry auto-calibration after checking if there is no problem with installed state such pneumatic leaks, lever position and others.
30	ZPdR +	Zero Point Drift	It is active if zero point or end point drifts +1% more than or -1 % less than initially set point while the Tight Shut Close or Tight Shut Open is enabled.
31	EPdR +	EndPoint Drift	The valve seat may be damaged or there may a linkage problem associated with lever.
33	COMM +	Communication Error Count Limit	It is active if the HART related communication errors exceed the setting. Check the cable connections or make sure that the environment is susceptible to noise.
34	FCLC +	Full Close Count Limit	It is active if the valve exceeds Full Close Count Limit.
35	FOPC +	Full Open Count Limit	It is active if the valve exceeds Full Open Count Limit.
36	LPCH +	Loop Current Hi Limit	It is active if the input current exceeds 20.5 mA.
37	LPCL	Loop Current Lo Limit	It is active if the input current falls below 3.8 mA.
38	DI1S +	Digital Input Status	It appears when Digital Input has been activated.
39	DO1S +	Digital Output Status	It appears when Digital Output 1 switch has been activated.
40	DIGF +	Diagnostics Failure	It indicates that the diagnosis test such as Large Step Test, Normal Step Test, Small Step Test, Stroke Time Test and Trace Test has failed.
41	DO2S +	Digital Output Status	It appears when Digital Output 2 switch has been activated.
145	VARA	Device Variable Alert	It is active when one of the internal variables are out of range.
144	MNTR ++	Maintenance Required	It is active when more than one of alarms assigned to "Maintenance Required" have happened. Remove the cause of the alarm after checking it.

Alarm Code	Abbreviation	Status / Alarm name	Description or proposed actions
147	FAIL ++	Failure	It is active when more than one of alarms assigned to "Failure" have happened. Remove the cause of the alarm after checking it.
148	OUTS ++	Out of Specification	It is active when more than one of alarms assigned to "Out of Specification" have happened. Remove the cause of the alarm after checking it.
149	FUNC ++	Function Check	It is active when more than one of alarms assigned to "Functional Check" have happened. Remove the cause of the alarm after checking it.
-	OVER CUR	Over Current	The input current exceeds 24mA.

## 9 Main Software Map

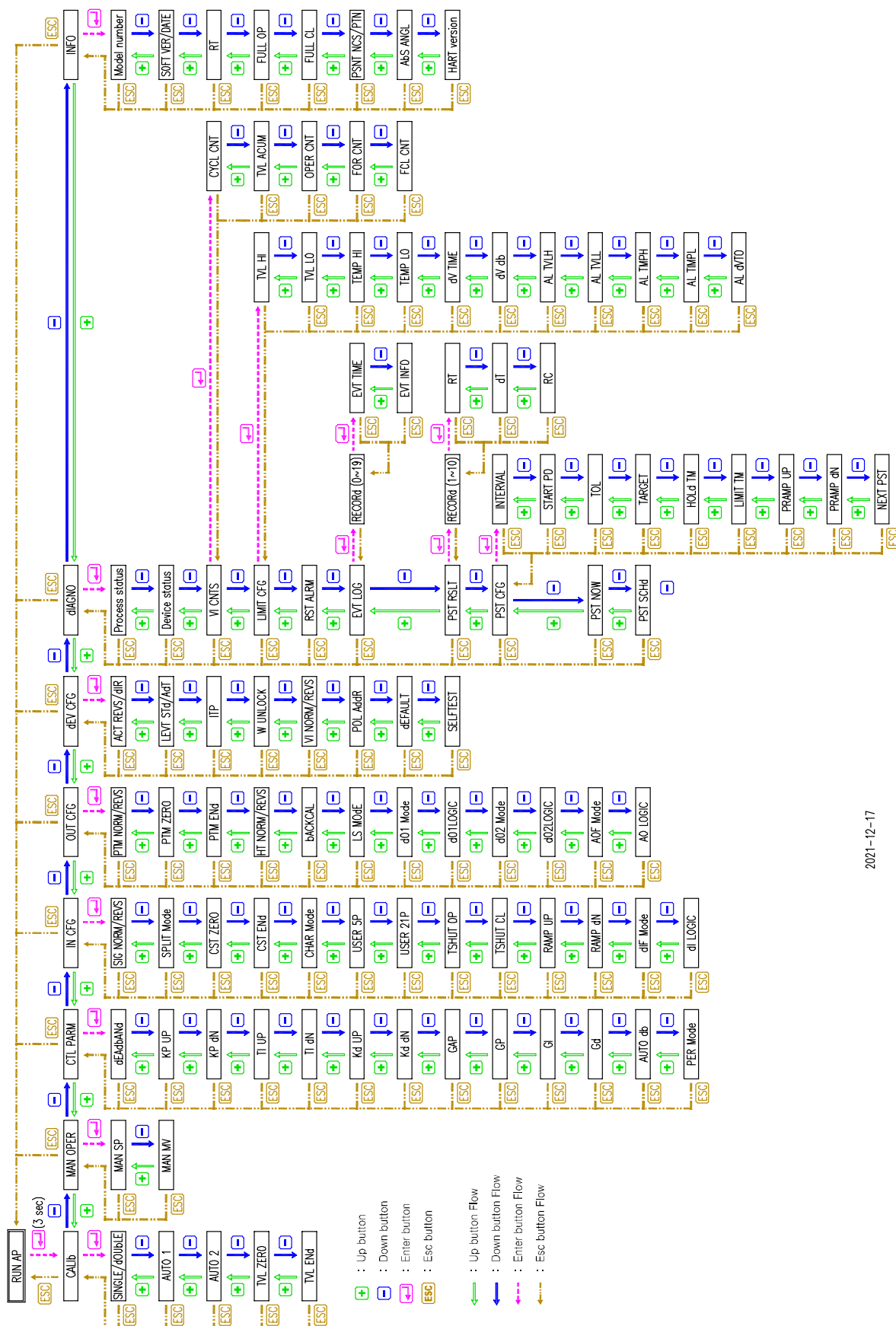

2021-12-17

---

**Manufacturer: Rotork YTC Limited**

Address: 81, Hwanggeum-ro, 89 Beon-gil, Yangchon-eup, Gimpo-si, Gyeonggi-do, South Korea

Postal code: 10048

Tel: +82-31-986-8545

Fax: +82-70-4170-4927

Email: [ytic.sales@rotork.com](mailto:ytic.sales@rotork.com)

Homepage : <http://www.ytc.co.kr>

Issued : 2022-12-08

---

Copyright © Rotork YTC Limited. All Rights Reserved.