

Max-Air
TECHNOLOGY



RIDUTTORI QUARTO DI GIRO
QUARTER TURN GEARING



RIDUTTORI MANUALI

MANUAL GEAR BOXES

SERIE GO



RIDUTTORI MANUALI - SERIE GO

La linea di riduttori manuali Max-Air è progettata per fornire una alternativa alla movimentazione delle valvole con leva per valvole anche di piccole dimensioni e fino ad una coppia di 16500 Nm.

Le forature multiple ISO presenti sulla maggior parte dei riduttori e la connessione femmina doppio quadro, consentono grande flessibilità nell'accoppiamento sulla valvola, rendendo la gamma Max-Air la scelta ideale sia per economicità che semplicità.

CARATTERISTICHE & BENEFICI

- **DESIGN COMPATTO:** Dimensioni contenute, design compatto e leggero in peso
- **FORATURA ISO:** Dotato di foratura secondo ISO5211 per un semplice, compatto ed economico montaggio sulla valvola
- **CONNESSIONE ISO:** Riduttore con doppio quadro secondo norme ISO 5211 ed eventuali riduzioni di varie misure per adattarlo a molteplici steli di valvole
- **RANGE DI COPPIE:** Ampio range di coppie disponibili, da 150 Nm a 16500 Nm
- **AFFIDABILITA':** Riduttore e volantino verniciati epossidico e resistenti alle condizioni atmosferiche, rendono i riduttori Max-Air affidabili e duraturi nel tempo anche in condizioni gravose
- **TEMPERATURE:** ampio range di temperatura -28°C +82°C (-20°F +180°F) con corrispondenti gasket e grasso speciale

MANUAL GEAR OPERATORS - GO SERIES

The manual gear operator line is designed to provide an alternative to lever handles and actuation for small and mid-range valve sizes with operating torques up to 16500 Nm.

Multiple ISO mounting patterns on most of the gears and double square female drives provide for a range of mounting options; whether economy or ease of operation are the driving priority of the purchase, Max-Air manual gear operators are the best solution.

FEATURES & BENEFITS

- **COMPACT DESIGN:** Small in volume, compact design and light weight
- **ISO MOUNTING FLANGES:** Equipped with ISO5211 bolt circles for an easy and cost effective actuator assembly
- **ISO VALVE CONNECTION:** Double Square connection according to ISO 5211 with adapters available for a wide variety of valve stem drives
- **TORQUE RANGE:** Wide torque range from 150 Nm to 16500 Nm
- **DURABILITY:** Epoxy coated housing and hand wheel in addition to weather resistant enclosures allow the GO Series gear operator to stand up in harsh environment.
- **TEMPERATURE RANGE:** Wide temperature range from -28°C to 82°C (-20°F to 180°F) with corresponding high and low temperature gaskets and grease

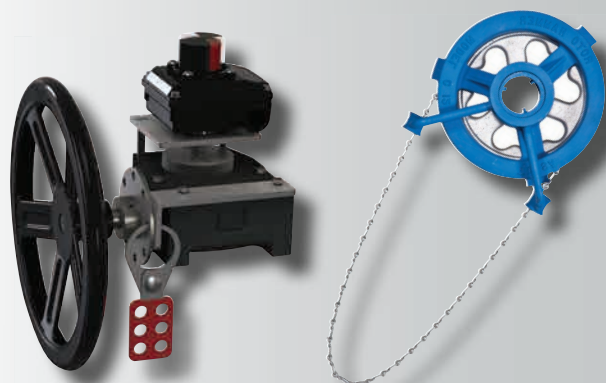

OPZIONI

CATENE: i riduttori possono essere forniti con catene a seconda dei requisiti del cliente

SISTEMI DI BLOCCAGGIO: su richiesta è possibile fornire un sistema per bloccare il riduttore

AVAILABLE OPTIONS

CHAIN WHEELS: standard or hammer blow chainwheels can be provided and installed per customer requirements

LOCKOUT DEVICE: a lockout device can be provided if required

RIDUTTORI MANUALI

MANUAL GEAR BOXES

Modello	Rapporto	Coppia Ingresso Nm *	Coppia Uscita Nm *	Diametro Volantino	Peso (kg)
Model	Gear Ratio	Input Torque Nm *	Output Torque Nm *	H-Wheel Diameter	Weight
GO-01-ISO	40:1	18	150	120	1.22
GO-02-ISO	37:1	22	250	200	2.56
GO-03-ISO	42:1	45	500	250	5.20
GO-04-ISO	42:1	90	1000	300	10.10
GO-05-ISO	60:1	110	1800	400	18.50
GO-06	68:1	165	3400	400	35.40
GO-07	88:1	165	4500	400	45.80
GO-08	184:1	150	7900	400	77.50
GO-09	250:1	150	10100	400	108.00
GO-10	720:1	150	16500	500	185.00



* These values are maximums and do not correspond to actual valve-gear assemblies

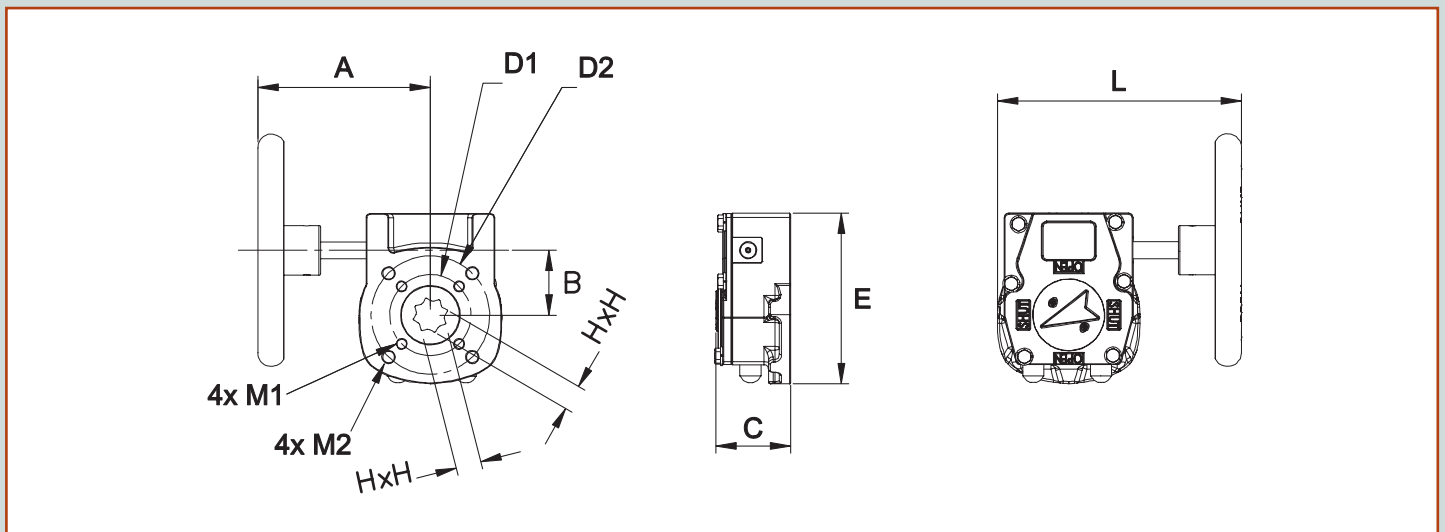

Model	A	B	C	E	L	HxH	Attacco valvola / Valve mounting					
							ISO	ØD1	4xM1	ISO	ØD2	4xM2
GO-01-ISO	101	45	48	110	146	11	F05	50	4xM6	F07	70	4xM8
GO-02-ISO	148	45	55	110	201	17	F07	70	4xM8	--	--	--
GO-03-ISO	180	53	62	145	240	22	F07	70	4xM8	F10	102	4xM10
GO-04A-ISO	214	66	78	184	290	27	F10	102	4xM10	F14	140	4xM16
GO-04B-ISO	214	66	78	184	290	27	F12	125	4xM12	--	--	--
GO-05A-ISO	206	89	87	240	306	46	F12	125	4xM12	F16	165	4xM20
GO-05B-ISO	206	89	87	240	306	46	F14	140	4xM16	--	--	--
GO-06A-ISO	277	123	91	252	403	80**	F14	140	4xM16	--	--	--
GO-06B-ISO	277	123	91	252	403	80**	F16	165	4xM20	--	--	--
GO-07	346	153	100	315	503.5	80**	F16	165	4xM20	F25	254	8xM16
GO-08	475	138	131	310	630	86**	F16	165	4xM20	F25	254	8xM16
GO-09	506	81	166	355	683.5	100**	F25	254	8xM16	F30	298	8xM20
GO-10	676	237	158	463	907.5	128**	F25	254	8xM16	F30	298	8xM20

** = refers to maximum diameter of shaft bore

ESPLOSO SERIE GO

GO SERIES EXPLODED VIEW

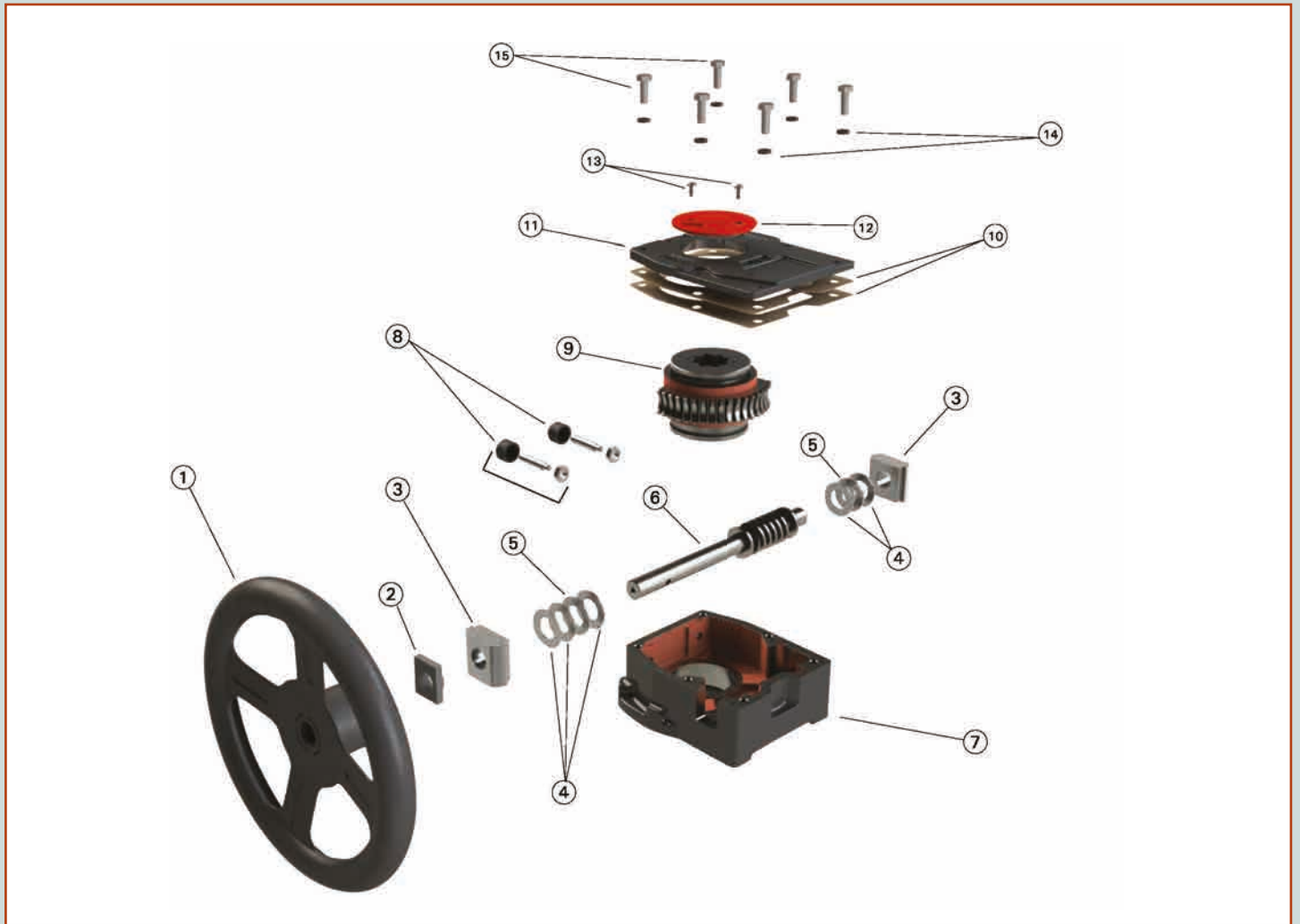

Item	Descrizione	Qtà	Materiale
1	Volantino	1	Ghisa Grigia o Acciaio
2	Gasket dello stelo	1	NBR
3	Supporto stelo	2	Acciaio zincato
4	Rondelle	5	Acciaio zincato
5	Boccole stelo	2	Acciaio zincato
6	Vite senza fine	1	Acciaio
7	Scatola	1	Ghisa Grigia
8	Grani di regolazione	2	Acciaio
9	Cremagliera	1	Ghisa sferoidale
10	Gasket della scatola	2	NBR
11	Coperchio	1	Ghisa Grigia
12	Indicatore	1	Acciaio
13	Viti indicatore	2	Acciaio zincato
14	Guarnizioni	6	NBR
15	Viti coperchio	6	Acciaio zincato

Item	Description	Qty	Materials
1	Hand Wheel	1	Steel or Cast Iron
2	Shaft Gasket	1	BUNA N
3	Shaft Holders	2	Plated Steel
4	Shaft Washers	5	Plated Carbon Steel
5	Shaft Bearings	2	Plated Carbon Steel
6	Worm Shaft	1	Carbon Steel
7	Body	1	Cast Iron
8	Travel Stops	2	Plated Steel
9	Segment Gear	1	Ductile Iron
10	Cover Gaskets	2	BUNA N
11	Cover	1	Cast Iron
12	Indicator	1	Plated Steel
13	Indicator Screws	2	Plated Carbon Steel
14	Screw OR	6	BUNA N
15	Cover Screws	6	Plated Carbon Steel

NOTA: la Emme Technology nella continua ricerca volta a migliorare ed ampliare la gamma dei prodotti si riserva il diritto di cambiare o modificare le caratteristiche tecniche di progetto e di costruzione senza preavviso e senza incorrere nell'obbligo di apportare tali modifiche sui prodotti precedentemente o successivamente venduti.

NOTE: In continuing research to improve and expand the range of its product, Emme Technology reserves the right to change or modify product design or construction without prior notice and without incurring any obligation to make such changes or modifications on products previously or subsequently sold.

RIDUTTORI SGANCIABILI CON DISPOSITIVO DI SBLOCCO PER COMANDO D'EMERGENZA

DECLUTCHABLE GEAR BOXES WITH UNLOCKING SYSTEM FOR EMERGENCY CONTROL

GOW SERIES



CARATTERISTICHE & BENEFICI

- Riduttore manuale di dimensioni contenute e leggero in peso
- Dotato di flangia integrata con foratura secondo ISO5211 per il montaggio diretto dell'attuatore
- Riduttore con doppio quadro secondo norme ISO 5211
- Ampio range di coppie disponibili, da 200 Nm a 4000 Nm

FEATURES & BENEFITS

- Small in volume, light weight
- Equipped with integral mounting flange according to ISO5211 for an easy and cost effective actuator assembly
- Double Square connection according to ISO 5211
- Wide torque range from 200 Nm to 4000 Nm

OPZIONI DISPONIBILI AVAILABLE OPTIONS



1. SAFETY SHIFT



2. LOCKOUT KIT

Modello	Rapporto	Coppia Ingresso Nm *	Coppia Uscita Nm *	Diametro Volantino	Peso (kg)
Model	Gear Ratio	Input Torque Nm *	Output Torque Nm *	H-Wheel Diameter	Weight
PV01-GOW0200	40.4 :1	22	200	200	5.5
PV01-GOW0600	57.4 :1	42	600	200	15
PV01-GOW0900	57.4 :1	70	900	250	16.6
PV01-GOW1200	57.4 :1	96	1200	300	17.7
PV01-GOW1600	65.6 :1	80	1600	350	33.3
PV01-GOW2000	65.6 :1	100	2000	400	34
PV01-GOW3300	74.4 :1	190	3300	600	54.6

Model	Attacco valvola / Valve Mounting											Attacco Attuatore / Actuator Mounting							
	□T2	H2	ISO	ØD3	4xM3	ISO	ØD4	4xM4	ISO	ØD5	4xM5	□T1	H1	ISO	ØD1	4xM1	ISO	ØD2	4xM2
PV01-GOW0200	17	25	F05	50	M6	--	50	--	F07	70	M8	14	17	F05	50	4-Ø7	F07	70	4-Ø9
PV01-GOW0600	27	30	F07	70	M8	--	70	--	F10	102	M10	22	22	F07	70	4-Ø9	F10	102	4-Ø11
PV01-GOW0900	27	30	F07	70	M8	F10	70	M10	F12	125	M12	27	28	F07	70	4-Ø9	F10	102	4-Ø11
PV01-GOW1200	27	30	F07	70	M8	F10	70	M10	F12	125	M12	27	28	F07	70	4-Ø9	F10	102	4-Ø11
PV01-GOW1600	36	40	F10	102	M10	--	102	--	F12	125	M12	36	34	F10	102	4-Ø11	F12	125	4-Ø13
PV01-GOW2000	36	40	F10	102	M10	--	102	--	F12	125	M12	36	34	F10	102	4-Ø11	F12	125	4-Ø13
PV01-GOW3300	46	176	F12	125	M12	--	125	--	F16	165	M20	46	45	F16	165	4-Ø22	F16	165	--
PV01-GOW4000	46	176	F12	125	M12	--	125	--	F16	165	M20	46	45	F16	165	4-Ø22	F16	165	--

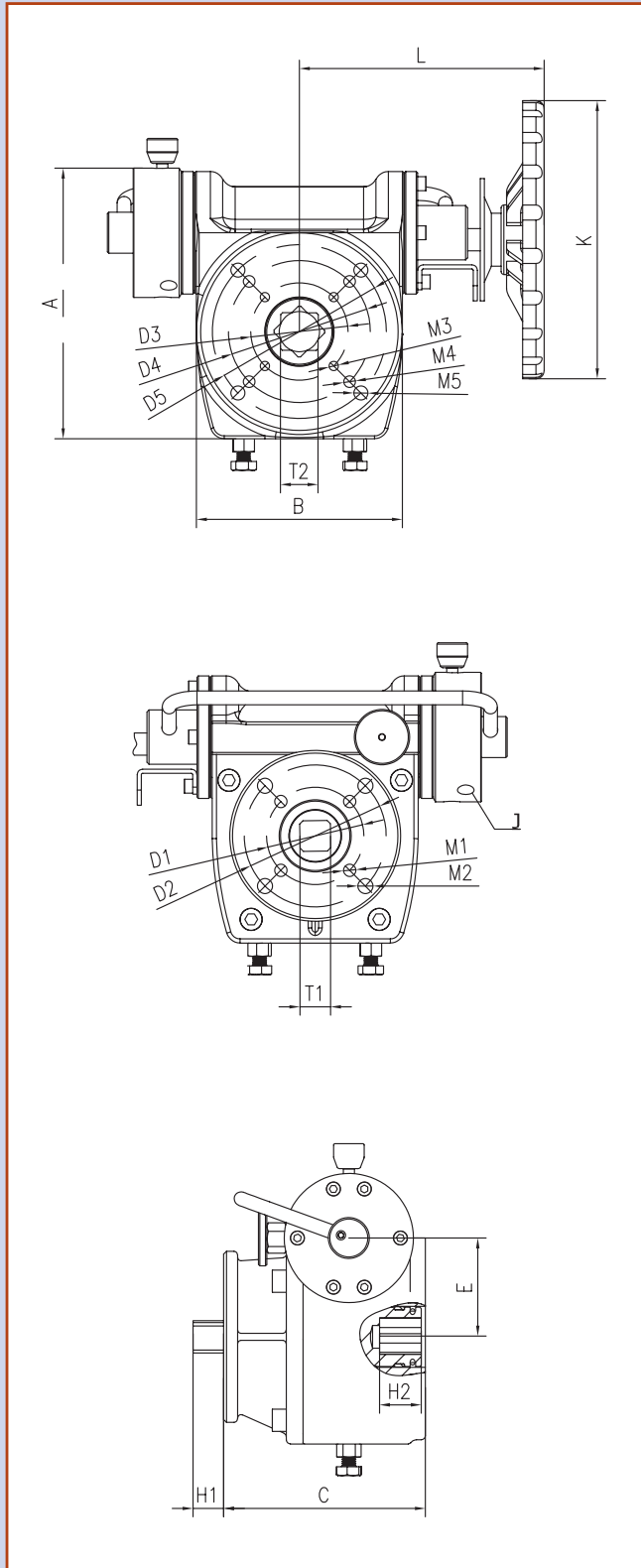

Model	A	B	C	E	L	ØK	J
PV01-GOW0200	120	100	104	44.5	120	200	1/4"NPT
PV01-GOW0600	192	148	145	71	175	200	1/4"NPT
PV01-GOW0900	192	148	145	71	178	250	1/4"NPT
PV01-GOW1200	192	148	145	71	181	300	1/4"NPT
PV01-GOW1600	260	196	191.5	107.5	268	350	1/4"NPT
PV01-GOW2000	260	196	191.5	107.5	272	400	1/4"NPT
PV01-GOW3300	334	255	181	123	272	600	1/4"NPT
PV01-GOW4000	334	255	181	123	272	700	1/4"NPT

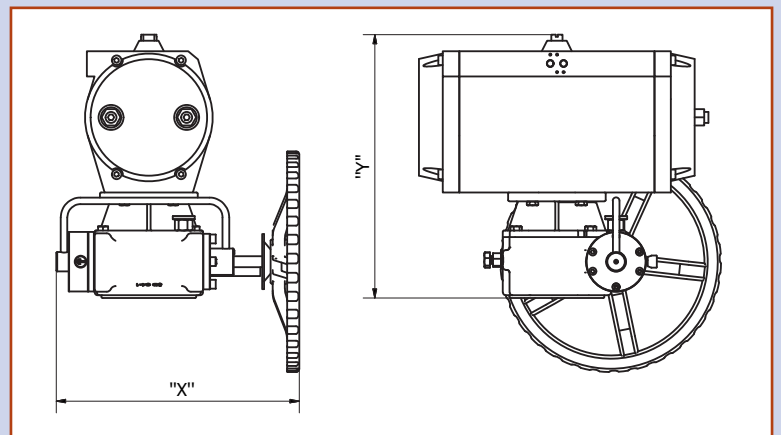

UT/MT Model	Gear Model	X	Y
05	/	/	/
07	PV01-GOW0200	232	202
15	PV01-GOW0200	232	215
17	PV01-GOW0200	232	215
20	PV01-GOW0200	232	232
25	PV01-GOW0200	232	232
30	PV01-GOW0200	232	251
35	PV01-GOW0600	314	329
40	PV01-GOW0600	314	329
45	PV01-GOW0600	314	343,5
50	PV01-GOW0900	312	377
55	PV01-GOW1200	312	377
60	PV01-GOW1600	436	478,5
65	PV01-GOW2000	440	478,5
70	PV01-GOW3300	454	539
75	PV01-GOW4000	454	539

ESPLOSO SERIE GOW

GOJ SERIES EXPLODED VIEW

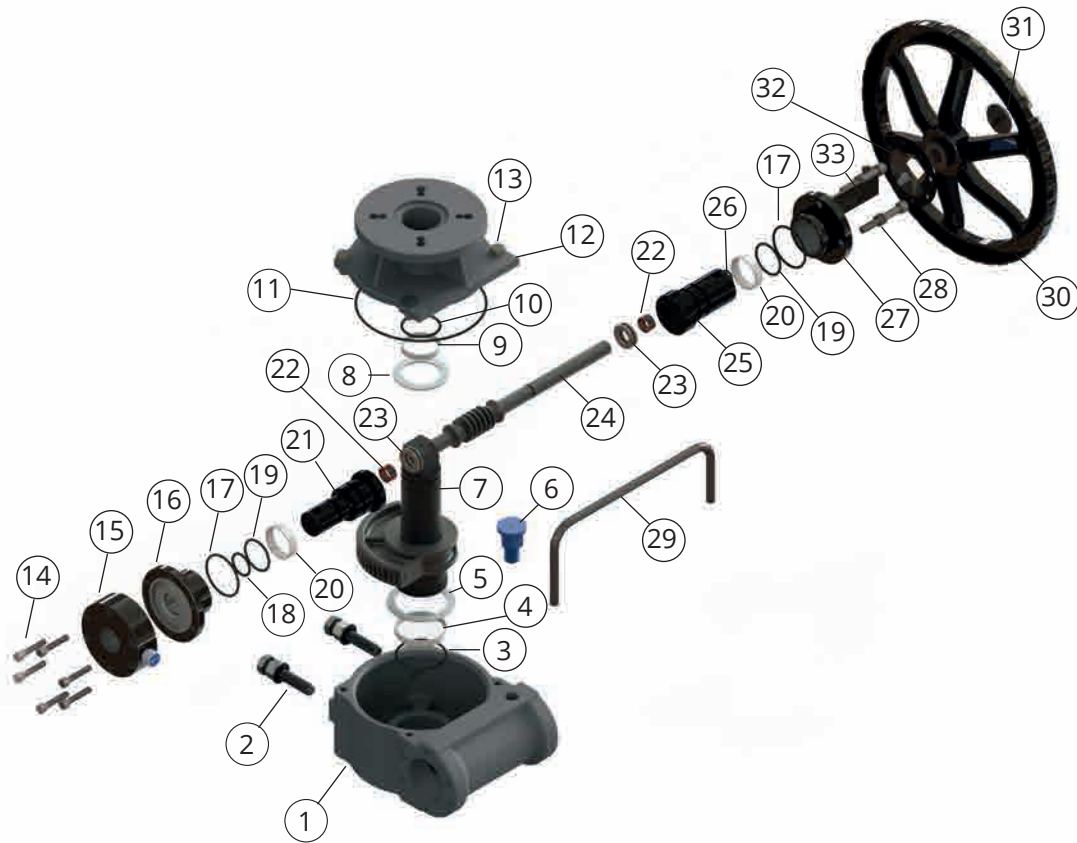

No.	Descrizione	Description	Qty	Material	No.	Descrizione	Description	Qty	Material
1	Corpo	Body	1	WCB	17	O-ring	O-ring	2	NBR
2	Vite di regolazione	Adj. bolt	2	304 & NBR	18	O-ring	O-ring	1	NBR
3	O-ring	O-ring	1	NBR	19	O-ring	O-ring	2	NBR
4	Boccola	Bearing	1	POM	20	Boccola	Eccentric axle bearing	2	POM
5	Anello piano	Bearing	1	POM	21	Stelo eccentrico post.	Eccentric half axle	1	C45
6	Perno di aggancio	Positioning unit	1	C45	22	Boccola	Bearing	2	Q235+PTFE
7	Albero con Ingranaggio	Shaft	1	C45	23	Cuscinetto	Thrust ball bearing	2	Steel
8	Anello piano	Bearing	1	POM	24	Vite senza fine	Worm shaft	1	C45
9	Boccola	Bearing	1	POM	25	Stelo eccentrico ant.	Eccentric half axle	1	C45
10	O-ring	O-ring	1	NBR	26	O-ring	O-ring	1	NBR
11	O-ring	O-ring	1	NBR	27	Supporto stelo ant.	Cap	1	C45
12	Coperchio con flangia	Cap	1	WCB	28	Viti	Screw	6	304
13	Vite	Screw	4	304	29	Maniglione	Shift handle	1	304
14	Vite	Screw	6	304	30	Volantino	Hand wheel	1	DI
15	Chiusura	Cap	1	C45	31	Distanziale e bullone	Washer and Bolt	1	C20 / SS
15A*	Chiusura con sicurezza aria	Air shift valve	1	Al Alloy	32*	Disco di blocco	Lock disc	1	20
16*	Supporto stelo post.	Cap	1	C45	33*	Dispositivo di blocco	Lock bracket	1	20

* = opzionale / option

ALTRI PRODOTTI

OTHER PRODUCTS

REV. 05-2018



ATTUATORI IN ALLUMINIO
ALUMINIUM ACTUATORS



RIDUTTORI SGANCIABILI
DECLUTCHABLE GEAR BOX



BOX FINE CORSA
LIMIT SWITCH BOX

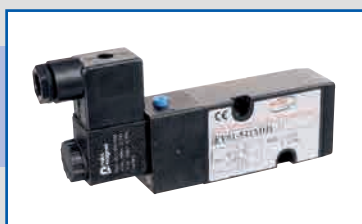

ELETTROVALVOLE NAMUR
NAMUR SOLENOID VALVE



POSIZIONATORI
POSITIONERS