



Drawing#:

5048MH

**050 Series
Ductile Iron Wafer
Resilient Seated
Butterfly Valve**

**△ P 200/150
Differential Pressure**

Sized for 80 PSI

**Applicable Trims:
262, 263, 579, 582,
780, 783, 962**



REV: 0 Date: 5/21/20

AUTOMATED BUTTERFLY VALVE ASSEMBLY

**CONFIG MA
DWG 1**

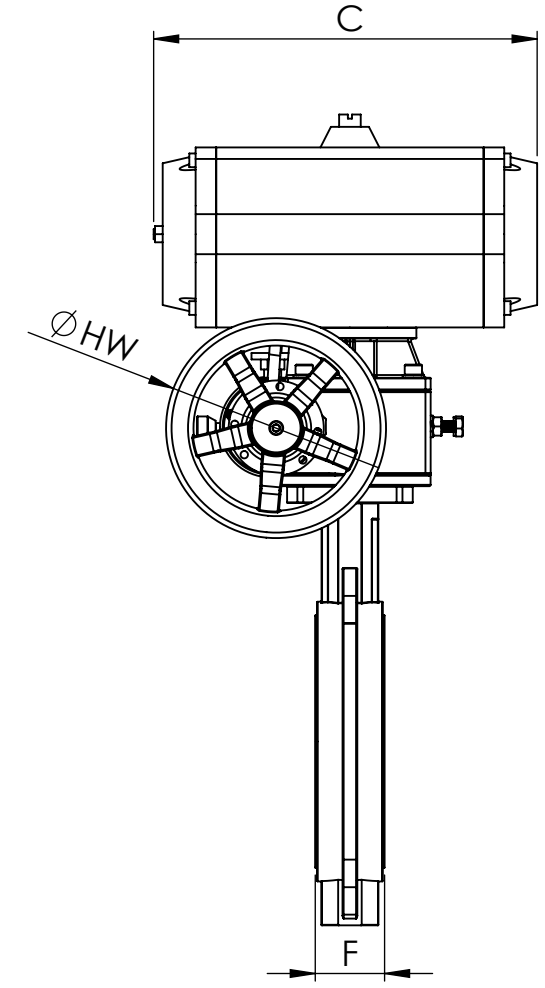
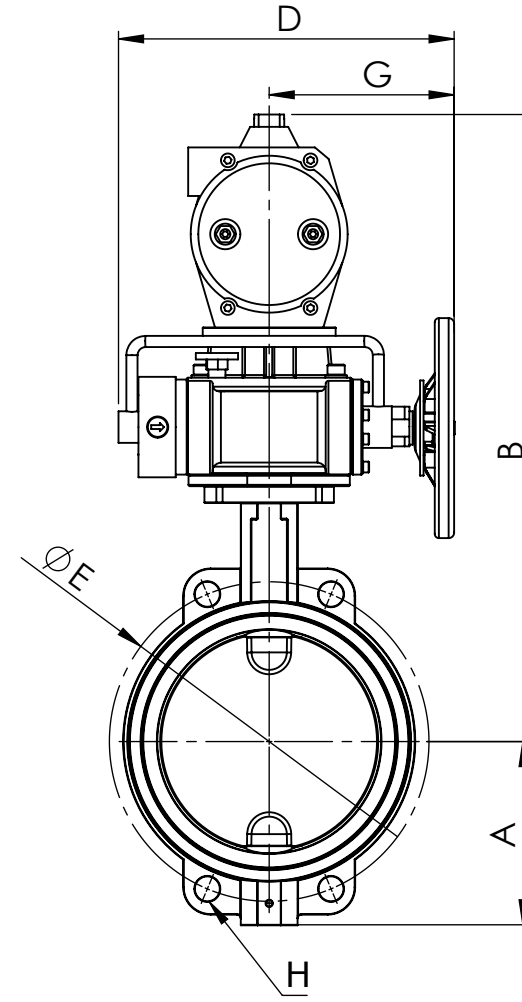
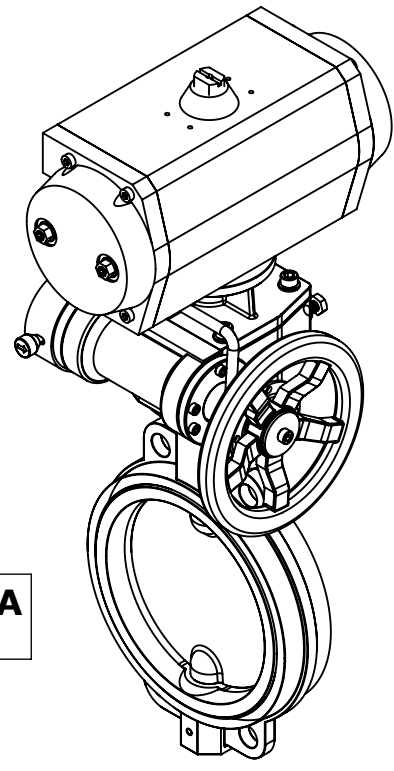

**CONFIG MA
DWG 2**

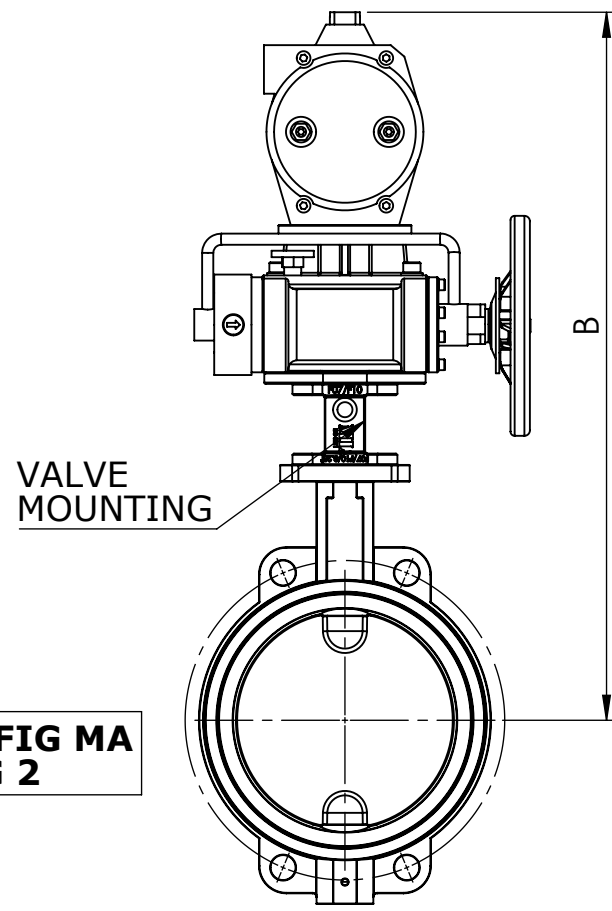

**CONFIG MA
DWG 3**

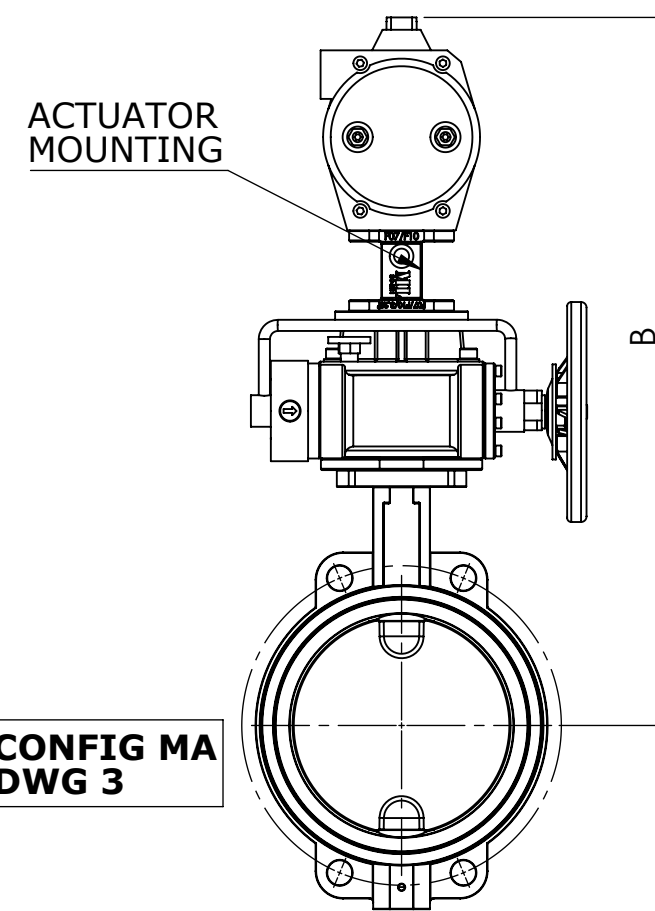

**CONFIG MA
DWG 4**

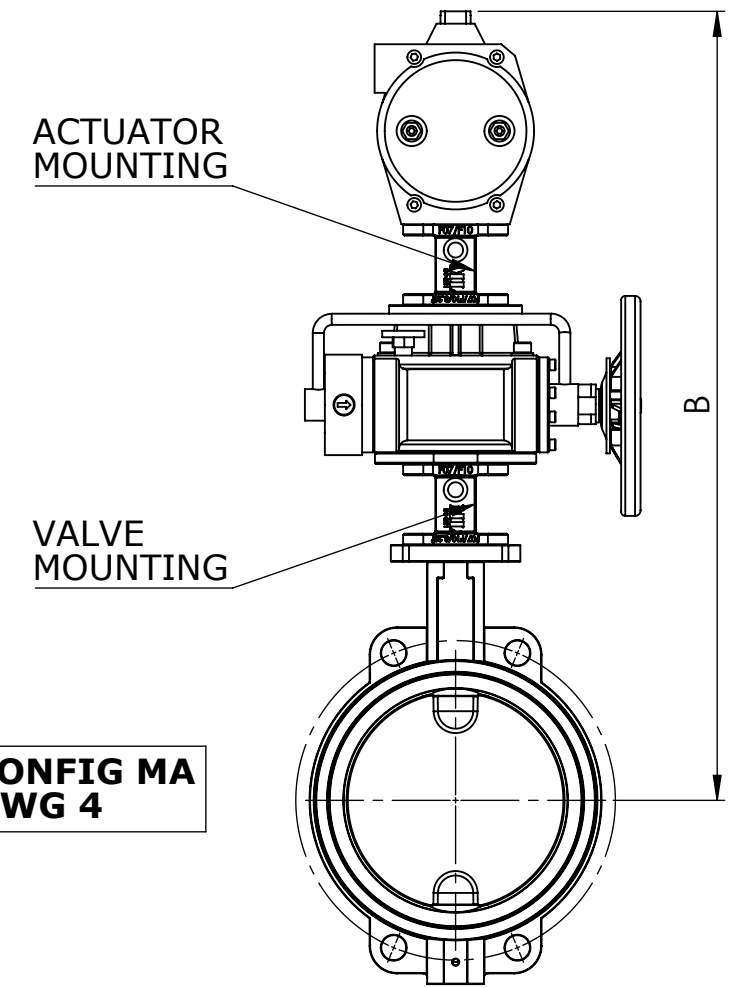

For larger sizes Reference Drawing:

5048YH

For Declutch free option Reference Drawing:

5048M0

*All dimensions in INCHES *All weights in POUNDS *For valve specific Features and Dimensions see valve cutsheet

ACTION	SERVICE	SIZE	DWG	A	B	C	D	E	F	H	G	Ø HW	VALVE MOUNTING	ACTUATOR MOUNTING	ACTUATOR	GEAR	WEIGHT
DOUBLE ACTING	WET MEDIA	2"	3	2.6	15.0	6.3	9.2	4.8	1.7	4 X .87	4.7	7.9	SSQ.17 X 9	KM08-G02	MT08.DA.F03-F05.CH11	GOW02	21
		2-1/2"	1	3.2	14.1	6.5	9.2	5.5	1.8	4 X .71	4.7	7.9	SSQ.17 X 9	-	MT16.DA.F05-F07.CH14	GOW02	22
		3"	1	3.5	14.3	7.8	9.2	6.0	1.8	8 X .71	4.7	7.9	SSQ.17 X 9	-	MT17.DA.F05-F07.CH14	GOW02	23
		4"	1	4.3	15.8	6.7	9.2	7.5	2.0	4 X .71	4.7	7.9	DSQ.17 X 11	DSQ.17 X 14	MT21.DA.F05-F07.CH17	GOW02	27
		5"	1	4.8	17.3	9.1	9.2	8.5	2.2	4 X .87	4.7	7.9	DSQ.17 X 14	DSQ.17 X 14	MT31.DA.F05-F07.CH17	GOW02	35
		6"	1	5.4	19.3	9.7	9.2	9.5	2.2	4 X .87	4.7	7.9	DSQ.17 X 14	DSQ.22 X 14	MT36.DA.F07-F10.CH22	GOW02	42
		8"	1	6.7	22.4	11.4	12.2	11.8	2.4	4 X 1.02	6.9	7.9	DSQ.27 X 17	-	MT41.DA.F07-F10.CH22	GOW06	78
		10"	1	7.9	25.5	14.2	12.2	14.3	2.7	4 X 1.02	6.9	7.9	DSQ.27 X 22	DSQ.27 X 22	MT51.DA.F10-F12.CH27	GOW06	110
		12"	1	9.3	26.8	16.5	12.0	17.0	3.1	4 X 1.02	7.0	9.8	DSQ.27 X 22	-	MT56.DA.F10-F12.CH27	GOW09	142
	14"	1	10.3	27.8	16.5	12.0	18.8	3.1	4 X 1.14	7.0	9.8	DSQ.27 X 22	-	MT56.DA.F10-F12.CH27	GOW09	168	
	16"	2	11.8	35.2	19.7	12.0	21.3	4.0	4 X 1.14	7.1	11.8	KG12-D160	DSQ.36 X 27	MT66.DA.F10-F12.CH36	GOW12	266	
	DRY AIR	2"	3	2.6	15.0	6.3	9.2	4.8	1.7	4 X .87	4.7	7.9	SSQ.17 X 9	KM08-G02	MT08.DA.F03-F05.CH11	GOW02	21
		2-1/2"	1	3.2	14.1	7.76	9.2	5.5	1.8	4 X .71	4.7	7.9	SSQ.17 X 9	-	MT17.DA.F05-F07.CH14	GOW02	23
		3"	1	3.5	14.9	6.7	9.2	6.0	1.8	8 X .71	4.7	7.9	SSQ.17 X 9	DSQ.17 X 14	MT21.DA.F05-F07.CH17	GOW02	24
		4"	1	4.3	15.8	9.4	9.2	7.5	2.0	4 X .71	4.7	7.9	DSQ.17 X 11	DSQ.17 X 14	MT26.DA.F05-F07.CH17	GOW02	29
		5"	1	4.8	17.3	9.1	9.2	8.5	2.2	4 X .87	4.7	7.9	DSQ.17 X 14	DSQ.17 X 14	MT31.DA.F05-F07.CH17	GOW02	35
		6"	1	5.4	19.3	9.7	9.2	9.5	2.2	4 X .87	4.7	7.9	DSQ.17 X 14	DSQ.22 X 14	MT36.DA.F07-F10.CH22	GOW02	42
		8"	1	6.7	22.9	13.8	12.2	11.8	2.4	4 X 1.02	6.9	7.9	DSQ.27 X 17	-	MT46.DA.F07-F10.CH22	GOW06	85
10"		1	7.9	25.5	16.5	12.2	14.3	2.7	4 X 1.02	6.9	7.9	DSQ.27 X 22	DSQ.27 X 22	MT56.DA.F10-F12.CH27	GOW06	119	
12"		1	9.3	29.0	17.5	12.0	17.0	3.1	4 X 1.02	7.0	9.8	DSQ.27 X 22	DSQ.36 X 27	MT61.DA.F10-F12.CH36	GOW09	160	
14"	1	10.3	30.0	17.5	12.0	18.8	3.1	4 X 1.14	7.0	9.8	DSQ.27 X 22	DSQ.36 X 27	MT61.DA.F10-F12.CH36	GOW09	186		
16"	2	11.8	33.0	19.8	17.1	21.3	4.0	4 X 1.14	10.6	13.8	KG16-D160	-	MT66.DA.F10-F12.CH36	GOW16	301		
SPRING RETURN	WET MEDIA	2"	1	2.6	14.2	6.7	9.2	4.8	1.7	4 X .87	4.7	7.9	SSQ.17 X 9	DSQ.17 X 14	MT21.S4.F05-F07.CH17	GOW02	22
		2-1/2"	1	3.2	14.7	9.4	9.2	5.5	1.8	4 X .71	4.7	7.9	SSQ.17 X 9	DSQ.17 X 14	MT26.S4.F05-F07.CH17	GOW02	27
		3"	1	3.5	15.7	9.1	9.2	6.0	1.8	8 X .71	4.7	7.9	SSQ.17 X 9	DSQ.17 X 14	MT31.S4.F05-F07.CH17	GOW02	29
		4"	1	4.3	18.0	9.7	9.2	7.5	2.0	4 X .71	4.7	7.9	DSQ.17 X 11	DSQ.22 X 14	MT36.S4.F07-F10.CH22	GOW02	39
		5"	1	4.8	20.4	13.8	12.2	8.5	2.2	4 X .87	6.9	7.9	SSQ.27 X 14	-	MT46.S3.F07-F10.CH22	GOW06	74
		6"	1	5.4	22.8	14.2	12.2	9.5	2.2	4 X .87	6.9	7.9	SSQ.27 X 14	DSQ.27 X 22	MT51.S3.F10-F12.CH27	GOW06	88
		8"	1	6.7	24.2	16.5	12.0	11.8	2.4	4 X 1.02	7.0	9.8	DSQ.27 X 17	-	MT56.S4.F10-F12.CH27	GOW09	115
		10"	1	7.9	29.5	19.8	17.1	14.3	2.7	4 X 1.02	10.6	13.8	SSQ.36 X 22	-	MT66.S4.F10-F12.CH36	GOW16	214
	DRY AIR	2"	1	2.6	14.2	9.4	9.2	4.8	1.7	4 X .87	4.7	7.9	SSQ.17 X 9	DSQ.17 X 14	MT26.S4.F05-F07.CH17	GOW02	25
		2-1/2"	1	3.2	15.5	9.1	9.2	5.5	1.8	4 X .71	4.7	7.9	SSQ.17 X 9	DSQ.17 X 14	MT31.S3.F05-F07.CH17	GOW02	29
		3"	1	3.5	15.7	9.1	9.2	6.0	1.8	8 X .71	4.7	7.9	SSQ.17 X 9	DSQ.17 X 14	MT31.S4.F05-F07.CH17	GOW02	29
		4"	1	4.3	18.0	9.7	9.2	7.5	2.0	4 X .71	4.7	7.9	DSQ.17 X 11	DSQ.22 X 14	MT36.S4.F07-F10.CH22	GOW02	39
		5"	1	4.8	20.4	13.8	12.2	8.5	2.2	4 X .87	6.9	7.9	SSQ.27 X 14	-	MT46.S4.F07-F10.CH22	GOW06	75
		6"	1	5.4	22.8	14.2	12.2	9.5	2.2	4 X .87	6.9	7.9	SSQ.27 X 14	DSQ.27 X 22	MT51.S4.F10-F12.CH27	GOW06	89
		8"	1	6.7	24.2	17.5	12.0	11.8	2.4	4 X 1.02	7.1	11.8	DSQ.27 X 17	DSQ.36 X 27	MT61.S5.F10-F12.CH36	GOW12	143
		10"	1	7.9	29.5	19.8	17.1	14.3	2.7	4 X 1.02	10.6	13.8	SSQ.36 X 22	-	MT66.S5.F10-F12.CH36	GOW16	218