



Drawing#:

5148M0

**051 Series
Ductile Iron Lug
Resilient Seated
Butterfly Valve**

**Δ P 200/150
Differential Pressure**

Sized for 80 PSI

**Applicable Trims:
262, 263, 579, 582,
780, 783, 962**



REV: 0 Date: 5/8/20

For larger sizes Reference Drawing:
5148Y0
For Declutch option Reference Drawing:
5148MH

AUTOMATED BUTTERFLY VALVE ASSEMBLY

**Config MA
Actuator
Parallel to
Pipeline
DWG 1**

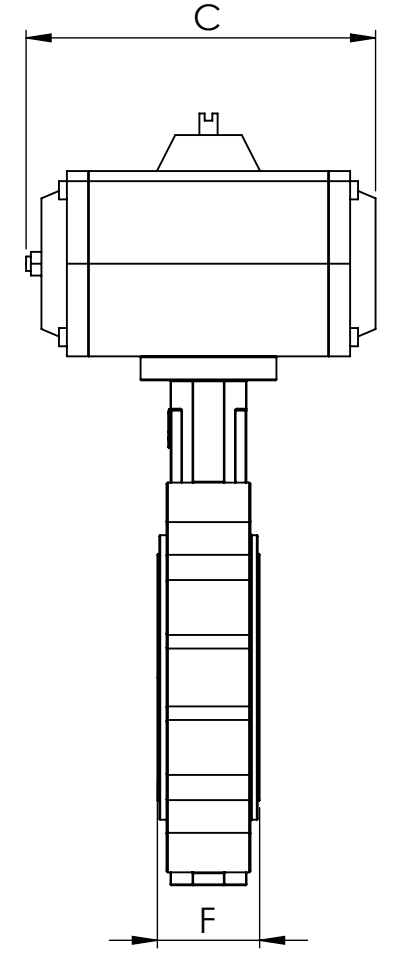
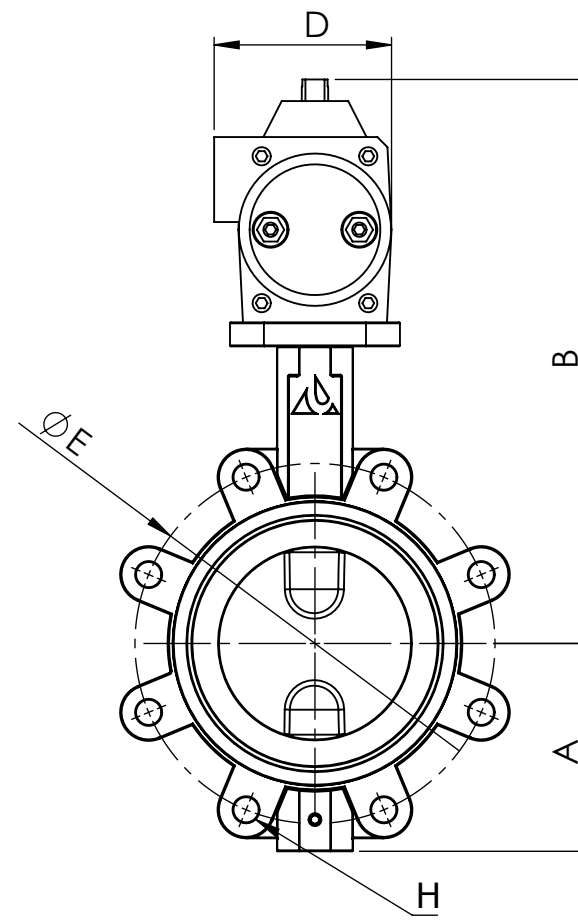
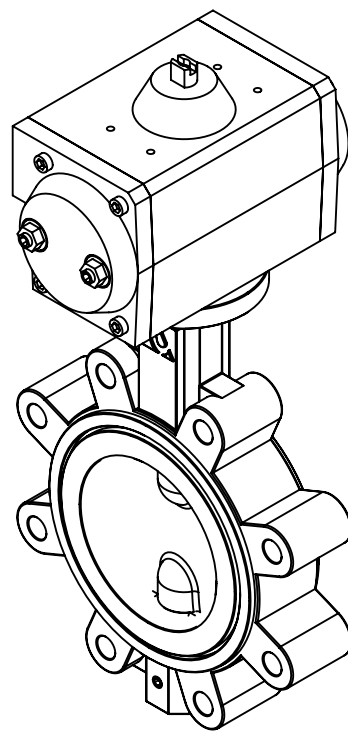

**Config MA
Actuator
Parallel to
Pipeline
DWG 2**

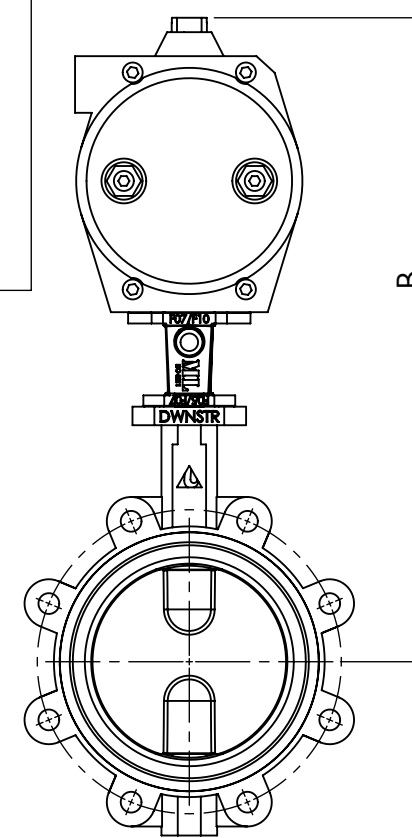
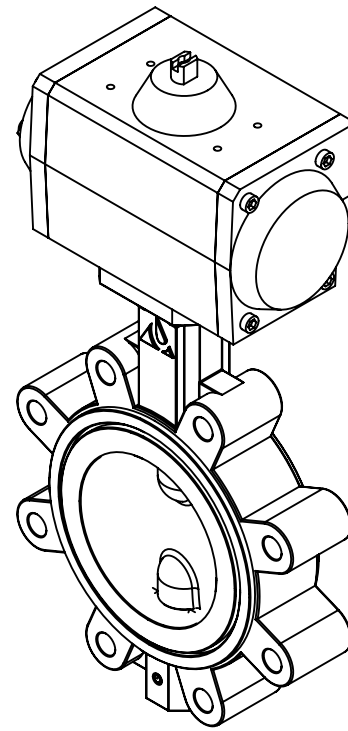

**Config MB
Actuator
Perpendicular
to Pipeline
DWG 2**

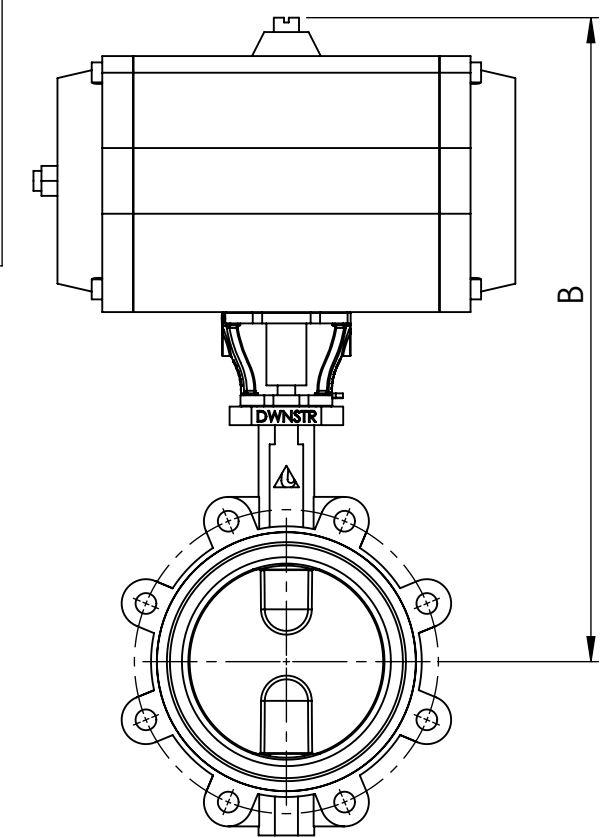

**Config MB
Actuator
Perpendicular
to Pipeline
DWG 1**

*All dimensions in INCHES *All weights in POUNDS *For valve specific Features and Dimensions see valve cutsheet

ACTION	SERVICE	SIZE	DWG	A	B	C	D	E	F	H	MOUNTING	ACTUATOR	WEIGHT	
DOUBLE ACTING	WET MEDIA	2"	1	2.6	9.0	6.3	2.8	4.8	1.7	4 x 5/8"-11	DSQ.11 X 9	MT08.DA.F03-F05.CH11	8	
		2-1/2"	1	3.2	10.0	6.5	3.2	5.5	1.8	4 x 5/8"-11	SSQ.14 X 9	MT16.DA.F05-F07.CH14	11	
		3"	1	3.5	10.5	7.8	3.2	6.0	1.8	4 x 5/8"-11	SSQ.14 X 9	MT17.DA.F05-F07.CH14	12	
		4"	1	4.3	11.7	6.7	3.8	7.5	2.0	8 x 5/8"-11	DSQ.17 X 11	MT21.DA.F05-F07.CH17	19	
		5"	1	4.8	13.2	9.1	4.5	8.5	2.2	8 x 3/4"-10	DSQ.17 X 14	MT31.DA.F05-F07.CH17	27	
		6"	1	5.4	15.5	9.7	5.2	9.5	2.2	8 x 3/4"-10	DSQ.22 X 14	MT36.DA.F07-F10.CH22	35	
		8"	1	6.7	16.6	11.4	5.2	11.8	2.4	8 x 3/4"-10	DSQ.22 X 17	MT41.DA.F07-F10.CH22	51	
		10"	1	7.9	19.8	14.2	7.1	14.3	2.7	12 x 7/8"-9	DSQ.27 X 22	MT51.DA.F10-F12.CH27	91	
		12"	1	9.3	21.1	16.5	7.1	17.0	3.1	12 x 7/8"-9	DSQ.27 X 22	MT56.DA.F10-F12.CH27	121	
		14"	1	10.3	22.1	16.5	7.1	18.8	3.1	12 x 1"-8	DSQ.27 X 22	MT56.DA.F10-F12.CH27	177	
	16"	1	11.8	25.5	19.7	9.1	21.3	4.0	16 x 1"-8	DSQ.36 X 27	MT66.DA.F10-F14.CH36	280		
	DRY AIR	2"	1	2.6	9.0	6.3	2.8	4.8	1.7	4 x 5/8"-11	DSQ.11 X 9	MT08.DA.F03-F05.CH11	8	
		2-1/2"	1	3.2	10.0	7.8	3.2	5.5	1.8	4 x 5/8"-11	SSQ.14 X 9	MT17.DA.F05-F07.CH14	12	
		3"	1	3.5	10.8	6.7	3.8	6.0	1.8	4 x 5/8"-11	SSQ.17 X 9	MT21.DA.F05-F07.CH17	13	
		4"	1	4.3	11.7	9.4	3.8	7.5	2.0	8 x 5/8"-11	DSQ.17 X 11	MT26.DA.F05-F07.CH17	21	
		5"	1	4.8	13.2	9.1	4.5	8.5	2.2	8 x 3/4"-10	DSQ.17 X 14	MT31.DA.F05-F07.CH17	27	
		6"	1	5.4	15.5	9.7	5.2	9.5	2.2	8 x 3/4"-10	DSQ.22 X 14	MT36.DA.F07-F10.CH22	35	
		8"	1	6.7	17.2	13.8	5.7	11.8	2.4	8 x 3/4"-10	DSQ.22 X 17	MT46.DA.F07-F10.CH22	58	
		10"	1	7.9	19.8	16.5	7.1	14.3	2.7	12 x 7/8"-9	DSQ.27 X 22	MT56.DA.F10-F12.CH27	100	
12"		1	9.3	23.3	17.5	9.1	17.0	3.1	12 x 7/8"-9	SSQ.36 X 22	MT61.DA.F10-F12.CH36	139		
14"		1	10.3	24.3	17.5	9.1	18.8	3.1	12 x 1"-8	SSQ.36 X 22	MT61.DA.F10-F12.CH36	195		
16"	1	11.8	25.5	19.8	9.1	21.3	4.0	16 x 1"-8	DSQ.36 X 27	MT66.DA.F10-F14.CH36	280			
SPRING RETURN	WET MEDIA	2"	1	2.6	10.1	6.7	3.8	4.8	1.7	4 x 5/8"-11	SSQ.17 X 9	MT21.S4.F05-F07.CH17	11	
		2-1/2"	1	3.2	10.6	9.4	3.8	5.5	1.8	4 x 5/8"-11	SSQ.17 X 9	MT26.S4.F05-F07.CH17	15	
		3"	1	3.5	11.6	9.1	4.5	6.0	1.8	4 x 5/8"-11	SSQ.17 X 9	MT31.S4.F05-F07.CH17	18	
		4"	1	4.3	13.9	9.7	5.2	7.5	2.0	8 x 5/8"-11	SSQ.22 X 11	MT36.S4.F07-F10.CH22	30	
		5"	1	4.8	15.2	13.8	5.7	8.5	2.2	8 x 3/4"-10	DSQ.22 X 14	MT46.S3.F07-F10.CH22	45	
		6"	2	5.4	20.1	14.2	7.1	9.5	2.2	8 x 3/4"-10	KM51-D060	MT51.S3.F10-F12.CH27	63	
		8"	1	6.7	18.5	16.5	7.1	11.8	2.4	8 x 3/4"-10	DSQ.27 X 17	MT56.S4.F10-F12.CH27	84	
		10"	1	7.9	22.0	19.8	9.1	14.3	2.7	12 x 7/8"-9	SSQ.36 X 22	MT66.S4.F10-F12.CH36	155	
		DRY AIR	2"	1	2.6	10.1	9.4	3.8	4.8	1.7	4 x 5/8"-11	SSQ.17 X 9	MT26.S4.F05-F07.CH17	13
			2-1/2"	1	3.2	11.4	9.1	4.5	5.5	1.8	4 x 5/8"-11	SSQ.17 X 9	MT31.S3.F05-F07.CH17	17
	3"		1	3.5	11.6	9.1	4.5	6.0	1.8	4 x 5/8"-11	SSQ.17 X 9	MT31.S4.F05-F07.CH17	18	
	4"		1	4.3	13.9	9.7	5.2	7.5	2.0	8 x 5/8"-11	SSQ.22 X 11	MT36.S4.F07-F10.CH22	30	
	5"		1	4.8	15.2	13.8	5.7	8.5	2.2	8 x 3/4"-10	DSQ.22 X 14	MT46.S4.F07-F10.CH22	46	
	6"		2	5.4	20.1	14.2	7.1	9.5	2.2	8 x 3/4"-10	KM51-D060	MT51.S4.F10-F12.CH27	64	
	8"		1	6.7	20.7	17.5	9.1	11.8	2.4	8 x 3/4"-10	SSQ.36 X 17	MT61.S5.F10-F12.CH36	110	
	10"		1	7.9	22.0	19.8	9.1	14.3	2.7	12 x 7/8"-9	SSQ.36 X 22	MT66.S5.F10-F12.CH36	158	