



Drawing#:

613PM0

**651 Series
Stainless Steel Lug
Resilient Seated
Butterfly Valve**

**△ P 150
Differential Pressure**

Sized for 80 PSI

**Applicable Trims:
482**



REV: 0 Date: 6/23/20

For larger sizes Reference Drawing:
613PY0
For Declutch option Reference Drawing:
613PMH

AUTOMATED BUTTERFLY VALVE ASSEMBLY

**Config MA
Actuator
Parallel to
Pipeline
DWG 1**

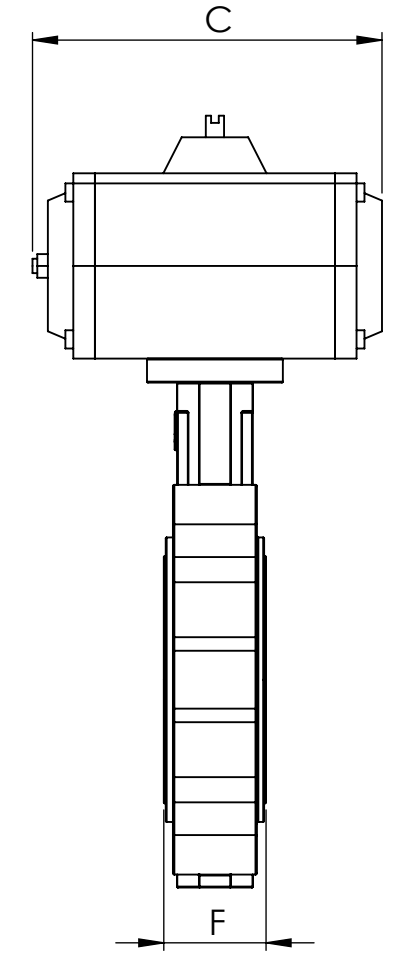
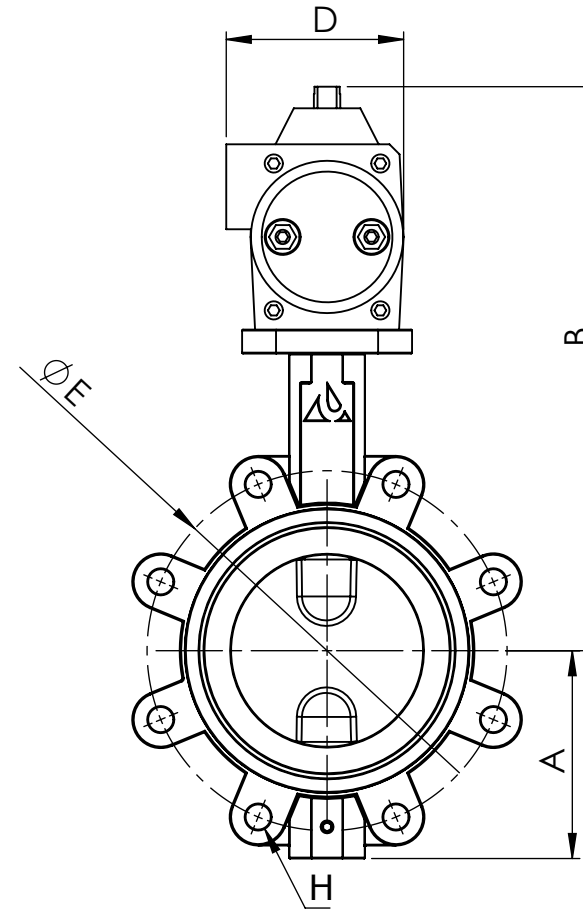
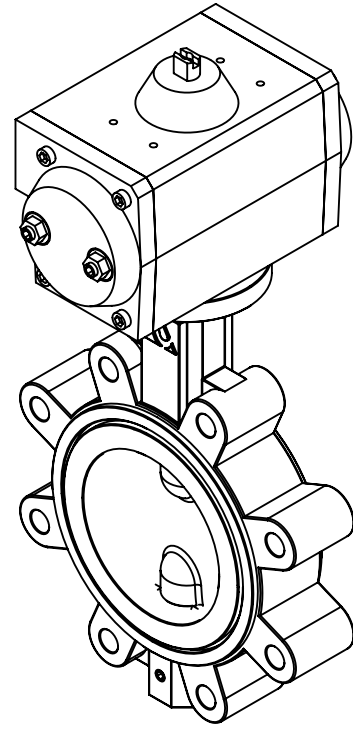

**Config MA
Actuator
Parallel to
Pipeline
DWG 2**

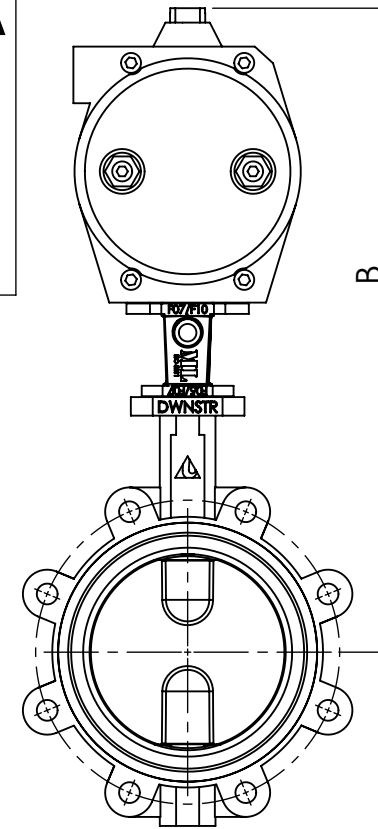
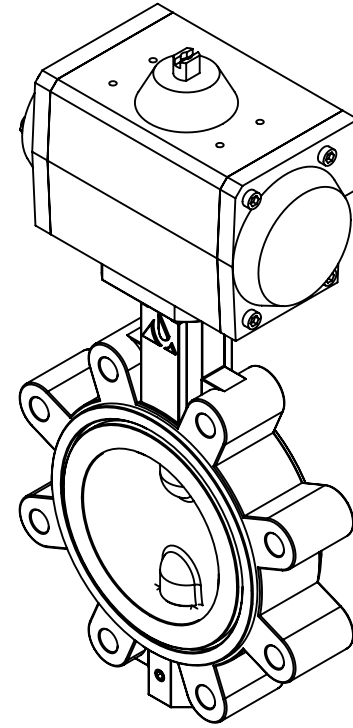

**Config MB
Actuator
Perpendicular
to Pipeline
DWG 2**

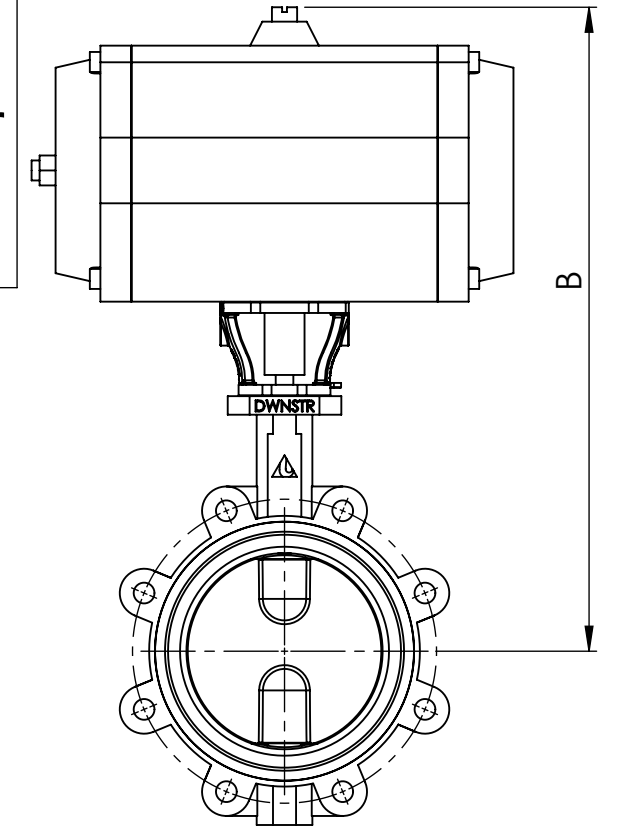

**Config MB
Actuator
Perpendicular
to Pipeline
DWG 1**

*All dimensions in INCHES *All weights in POUNDS *For valve specific Features and Dimensions see valve cutsheet

ACTION	SERVICE	SIZE	DWG	A	B	C	D	E	F	H	MOUNTING	ACTUATOR	WEIGHT
DOUBLE ACTING	WET MEDIA	2"	1	2.6	9.0	6.3	2.8	4.8	1.7	4 x 5/8"-11	DSQ.11 X 9	MT08.DA.F03-F05.CH11	9
		2-1/2"	1	3.2	10.0	6.5	3.2	5.5	1.8	4 x 5/8"-11	SSQ.14 X 9	MT16.DA.F05-F07.CH14	11
		3"	1	3.5	10.8	6.7	3.8	6.0	1.8	4 x 5/8"-11	DSQ.17 X 11	MT21.DA.F05-F07.CH17	14
		4"	1	4.3	11.7	9.4	3.8	7.5	2.0	8 x 5/8"-11	DSQ.17 X 11	MT26.DA.F05-F07.CH17	21
		5"	1	4.8	14.6	9.7	5.2	8.5	2.2	8 x 3/4"-10	DSQ.22 X 14	MT36.DA.F07-F10.CH22	32
		6"	1	5.4	15.2	9.7	5.2	9.5	2.2	8 x 3/4"-10	DSQ.22 X 14	MT36.DA.F07-F10.CH22	36
		8"	1	6.7	17.2	13.8	5.7	11.8	2.4	8 x 3/4"-10	DSQ.22 X 17	MT46.DA.F07-F10.CH22	59
		10"	1	7.9	19.8	14.2	7.1	14.3	2.7	12 x 7/8"-9	DSQ.27 X 22	MT51.DA.F10-F12.CH27	91
		12"	1	9.3	23.3	17.5	9.1	17.0	3.1	12 x 7/8"-9	SSQ.36 X 22	MT61.DA.F10-F12.CH36	140
	DRY AIR	2"	1	2.6	9.5	6.5	3.2	4.8	1.7	4 x 5/8"-11	SSQ.14 X 9	MT16.DA.F05-F07.CH14	10
		2-1/2"	1	3.2	10.0	6.5	3.2	5.5	1.8	4 x 5/8"-11	SSQ.14 X 9	MT16.DA.F05-F07.CH14	11
		3"	1	3.5	10.8	6.7	3.8	6.0	1.8	4 x 5/8"-11	DSQ.17 X 11	MT21.DA.F05-F07.CH17	14
		4"	1	4.3	11.7	9.4	3.8	7.5	2.0	8 x 5/8"-11	DSQ.17 X 11	MT26.DA.F05-F07.CH17	21
		5"	1	4.8	14.6	9.7	5.2	8.5	2.2	8 x 3/4"-10	DSQ.22 X 14	MT36.DA.F07-F10.CH22	32
		6"	1	5.4	15.2	11.4	5.2	9.5	2.2	8 x 3/4"-10	DSQ.22 X 14	MT41.DA.F07-F10.CH27	39
		8"	1	6.7	18.5	14.2	7.1	11.8	2.4	8 x 3/4"-10	DSQ.27 X 17	MT51.DA.F10-F12.CH27	70
		10"	1	7.9	19.8	16.5	7.1	14.3	2.7	12 x 7/8"-9	DSQ.27 X 22	MT56.DA.F10-F12.CH27	100
		12"	1	9.3	23.3	17.5	9.1	17.0	3.1	12 x 7/8"-9	SSQ.36 X 22	MT61.DA.F10-F12.CH36	140
SPRING RETURN	WET MEDIA	2"	1	2.6	10.1	9.4	3.8	4.8	1.7	4 x 5/8"-11	SSQ.17 X 9	MT26.S4.F05-F07.CH17	14
		2-1/2"	1	3.2	10.6	9.4	3.8	5.5	1.8	4 x 5/8"-11	SSQ.17 X 9	MT26.S4.F05-F07.CH17	15
		3"	2	3.5	15.0	9.7	5.2	6.0	1.8	4 x 5/8"-11	KM36-D030	MT36.S3.F07-F10.CH22	27
		4"	1	4.3	13.9	9.7	5.2	7.5	2.0	8 x 5/8"-11	SSQ.22 X 11	MT36.S4.F07-F10.CH22	30
		5"	1	4.8	15.2	13.8	5.7	8.5	2.2	8 x 3/4"-10	DSQ.22 X 14	MT46.S4.F07-F10.CH22	46
		6"	2	5.4	20.1	14.2	7.1	9.5	2.2	8 x 3/4"-10	KM51-D060	MT51.S4.F10-F12.CH27	65
		8"	1	6.7	20.7	17.5	9.1	11.8	2.4	8 x 3/4"-10	SSQ.36 X 17	MT61.S4.F10-F12.CH36	111
		10"	1	7.9	22.0	19.8	9.1	14.3	2.7	12 x 7/8"-9	SSQ.36 X 22	MT66.S5.F10-F12.CH36	158
		DRY AIR	2"	1	2.6	10.1	9.4	3.8	4.8	1.7	4 x 5/8"-11	SSQ.17 X 9	MT26.S4.F05-F07.CH17
	2-1/2"		1	3.2	11.4	9.1	4.5	5.5	1.8	4 x 5/8"-11	SSQ.17 X 9	MT31.S3.F05-F07.CH17	17
	3"		2	3.5	15.0	9.7	5.2	6.0	1.8	4 x 5/8"-11	KM36-D030	MT36.S4.F07-F10.CH22	27
	4"		1	4.3	13.9	11.4	5.2	7.5	2.0	8 x 5/8"-11	SSQ.22 X 11	MT41.S4.F07-F10.CH22	33
	5"		2	4.8	19.5	14.2	7.1	8.5	2.2	8 x 3/4"-10	SSQ.27 X 14	MT51.S3.F10-F12.CH27	56
	6"		2	5.4	20.1	16.5	7.1	9.5	2.2	8 x 3/4"-10	KM51-D060	MT56.S4.F10-F12.CH27	76
	8"		1	6.7	20.7	17.5	9.1	11.8	2.4	8 x 3/4"-10	SSQ.36 X 17	MT61.S4.F10-F12.CH36	111