



Drawing#:

613PY0

**651 Series
Stainless Steel Lug
Resilient Seated
Butterfly Valve**

**△ P 150
Differential Pressure**

Sized for 80 PSI

**Applicable Trims:
482**



REV: 0 Date: 6/23/20

AUTOMATED BUTTERFLY VALVE ASSEMBLY

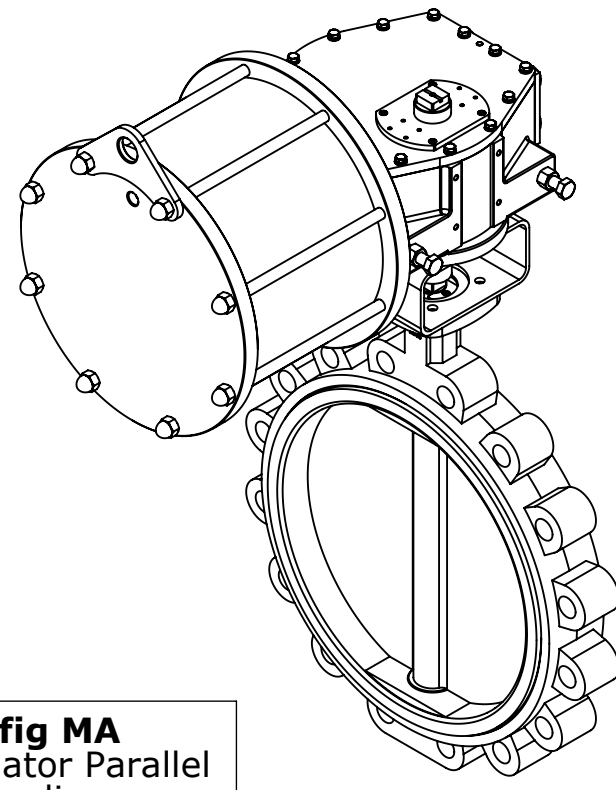

Config MA
Actuator Parallel
to Pipeline
Double Acting

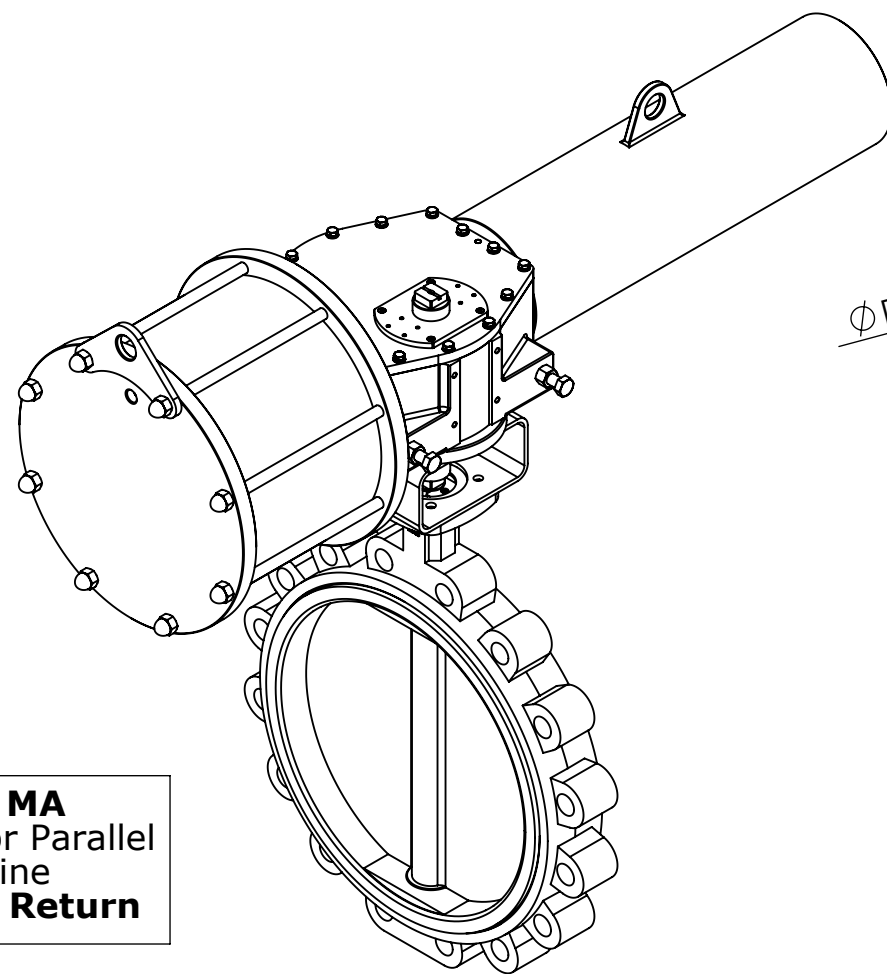
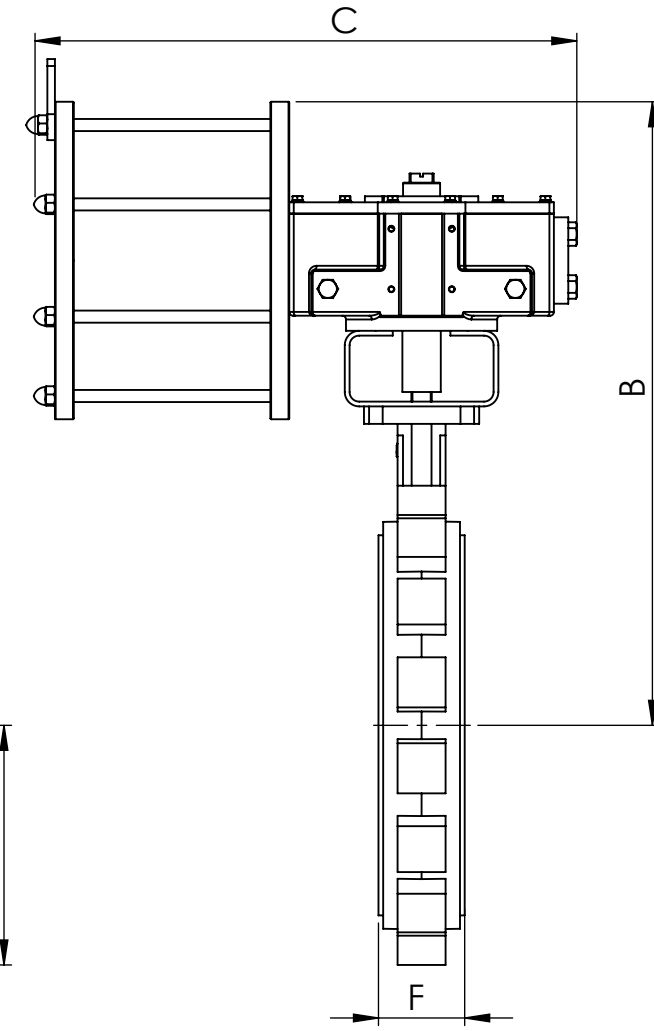
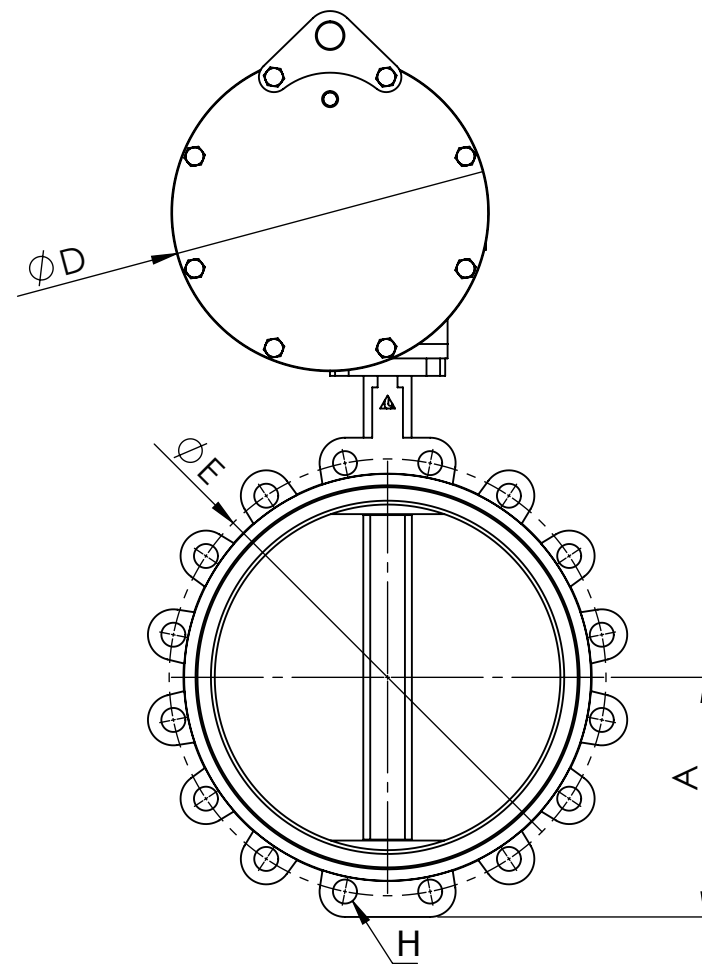

Config MA
Actuator Parallel
to Pipeline
Spring Return

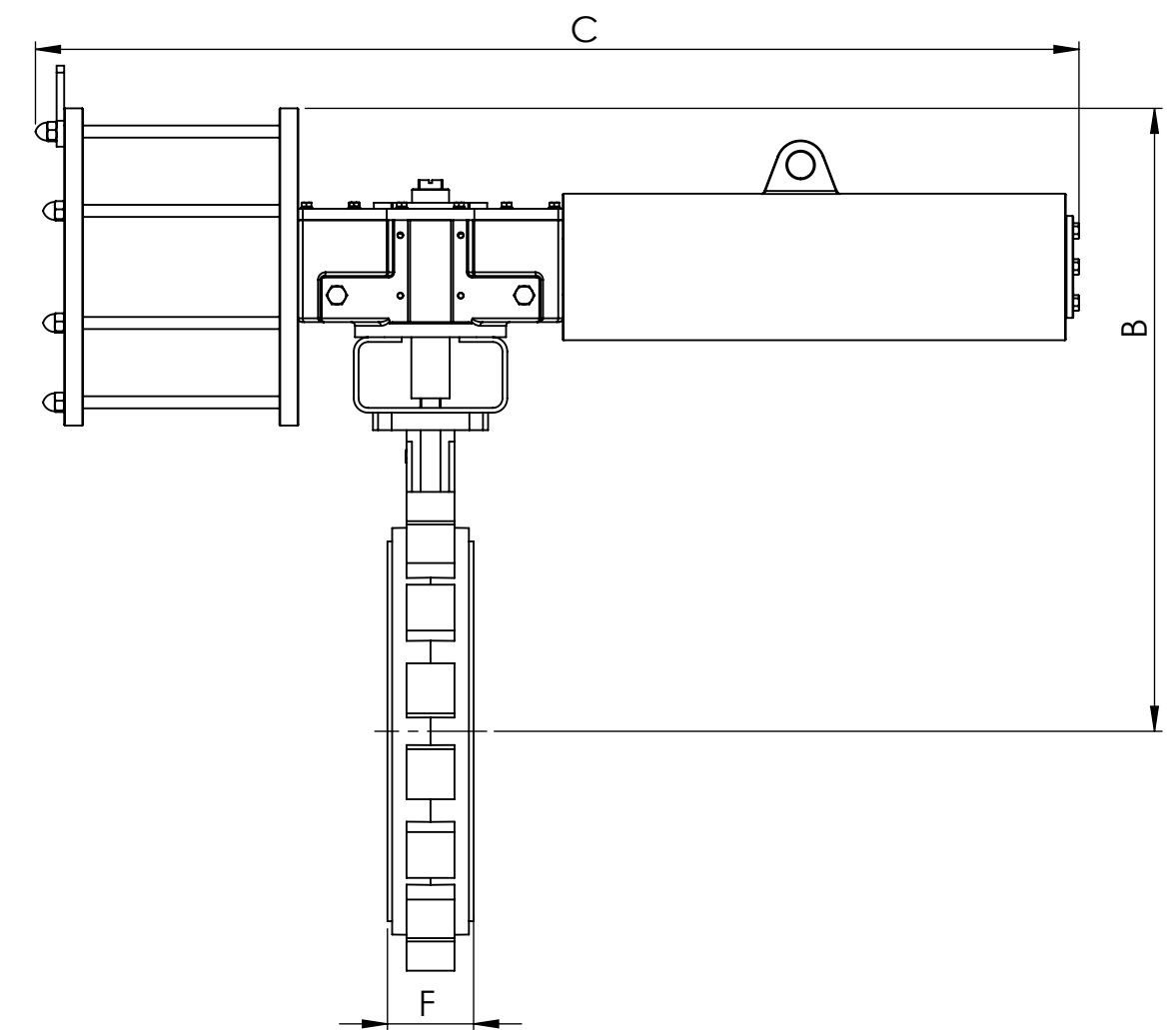
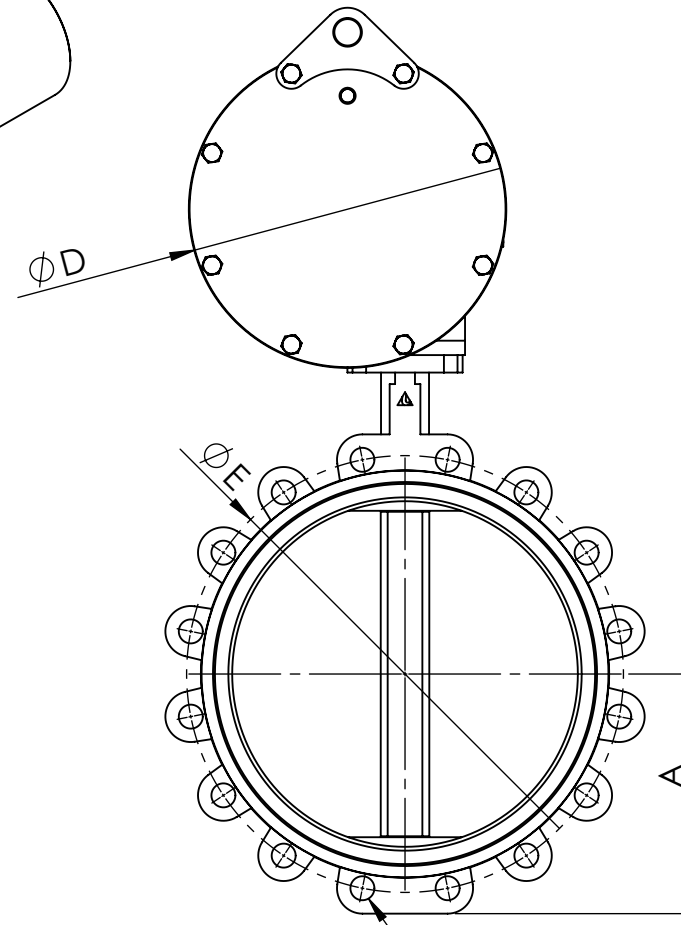

For smaller sizes Reference Drawing:

613PM0

For Jackscrew/Handpump

Option Reference Drawing:

613PYH

*For MB Actuator Mounted
Perpendicular to Valve Please
Contact Manufacturer

*All dimensions in INCHES *All weights in POUNDS *For valve specific Features and Dimensions see valve cutsheet

ACTION	SERVICE	SIZE	A	B	C	D	E	F	H	MOUNTING	ACTUATOR	WEIGHT
DOUBLE ACTING	WET MEDIA	14"	10.3	26.8	31.5	12.7	18.8	3.1	12 x 1"-8	KY16-D140	SHD16-U025001	405
	SERVICE	SIZE	A	B	C	D	E	F	H	MOUNTING	ACTUATOR	WEIGHT
	DRY AIR	14"	10.3	26.8	31.5	12.7	18.8	3.1	12 x 1"-8	KY16-D140	SHD16-U025001	405
ACTION	SERVICE	SIZE	A	B	C	D	E	F	H	MOUNTING	ACTUATOR	WEIGHT
SPRING RETURN	WET MEDIA	12"	9.3	25.8	52.2	12.7	17.0	3.1	12 x 7/8"-9	KY16-D120	SHD16-U025A01	460
		14"	10.3	28.4	52.2	16.1	18.8	3.1	12 x 1"-8	KY16-D140	SHD16-U035B01	658
	SERVICE	SIZE	A	B	C	D	E	F	H	MOUNTING	ACTUATOR	WEIGHT
	DRY AIR	10"	7.9	23.5	52.2	10.7	14.3	2.7	12 x 7/8"-9	KY16-D100	SHD16-U020B01	383
		12"	9.3	25.8	52.2	12.7	17.0	3.1	12 x 7/8"-9	KY16-D120	SHD16-U025B01	460
		14"	10.3	30.5	59.4	16.1	18.8	3.1	12 x 1"-8	KY25-D140	SHD25-U035B01	926